













3  
Q2  
461  
ES33  
V. 6  
Ent.

685886  
30  
Linné

13

ANNALS  
OF  
The Entomological Society of America

---

VOLUME VI, 1913

---

EDITORIAL BOARD

- |   |                                     |
|---|-------------------------------------|
| J. H. COMSTOCK,<br>ITHACA, N. Y.              | L. O. HOWARD,<br>WASHINGTON, D. C.  |
| C. J. S. BETHUNE,<br>GUELPH, ONTARIO, CANADA. | W. M. WHEELER,<br>BOSTON, MASS.     |
| C. W. JOHNSON,<br>BOSTON, MASS.               | P. P. CALVERT,<br>PHILADELPHIA, PA. |
| V. L. KELLOG,<br>STANFORD UNIV., CAL.         | J. W. FOLSOM,<br>URBANA, ILLS.      |

HERBERT OSBORN, *Managing Editor*,  
COLUMBUS, OHIO.

---

PUBLISHED QUARTERLY BY THE SOCIETY  
COLUMBUS, OHIO



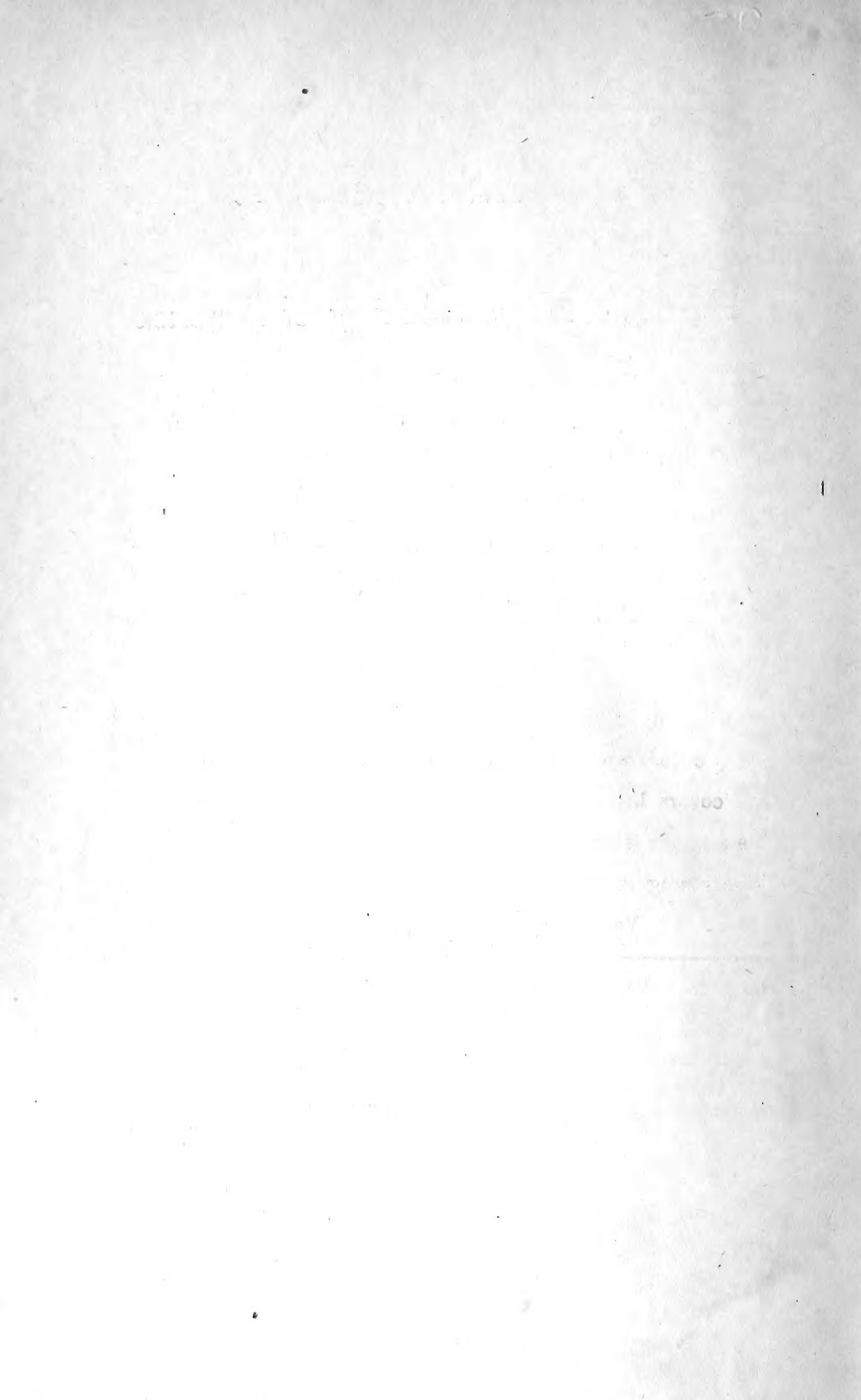



## CONTENTS OF VOLUME VI.

	PAGE
An Entomologist in Costa Rica. P. P. CALVERT.....	1
Determining the Flight of Mosquitos. JAMES ZETEK.....	5
A Revision of the North American Species of the Dipterous Genus Neurigona. M. C. VANDUZEE.....	22
An Interesting Feature in the Venation of Helicopsysche, the Molannidae, and the Leptoceridae. CORNELIUS BETTEN.....	65
Homologies of the Wing Veins of the Membracidae. W. D. FUNKHOUSER....	74
The Wing Venation of the Jassidae. Z. P. METCALF.....	103
A New Hymenopterous Parasite on Aspidiotus Perniciosus Comst. D. G. TOWER.....	125
Officers of the Entomological Society of America.....	127
Resolutions: On the Death of John B. Smith.....	128
On the Death of Thomas H. Montgomery.....	129
Proceedings of the Entomological Society of America—Cleveland Meeting..	130
A Revision of the North American Species of Megastigmus Dalman. C. R. CROSBY.....	155
The Neuropterous Genus Palpares. NATHAN BANKS.....	171
Stomoxys Calcitrans Linn. Part II. CHAS. K. BRAIN.....	197
The Biology of Perla Immarginata Say. LUCY W. SMITH.....	203
The Life-History of a Bee-Fly (Spogostylum Anale Say) Parasite of the Larva of a Tiger Beetle (Cicindela Scutellaris Say Var. Lecontei Hald). VICTOR E. SHELFORD.....	213
A New Application of Taxonomic Principles. CHAS. H. T. TOWNSEND.....	226
A Study in Antennal Variation. EDITH M. PATCH.....	233
A Study in Variation in the North American Greenbottle Flies of the Genus Lucilia, with Systematic Notes on the Species Involved. JOHN K. TOTHILL.....	241
Observations on the Chaetotaxy of Calliphorinae. PHINEAS W. WHITING....	257
A Revision of the Species in Agromyza Fallen, and Cerodontha Rondani. J. R. MALLOCH.....	269
The Wing Venation of Fulgoridae. Z. P. METCALF.....	341
The Princeton Collection of Fossil Beetles from Florissant. H. F. WICKHAM	359
A Contribution to the Biology of May-Flies. ANNA H. MORGAN.....	371
The External Anatomy of the Squash Bug, Anasa Tristis, De G. DANIEL G. TOWER.....	427
The Dipteran Fauna of Bermuda CHAS. W. JOHNSON.....	443
The Taxonomic Value of the Characters of the Male Genital Armature in the Genus Tetranychus, Dufour. H. E. EWING.....	453
A Synopsis of the Described North American Species of the Dipterous Genus Tipula L. W. G. DIETZ.....	461
Some Pemphiginae Attacking Species of Populus in Colorado. C. P. GILLETTE.	485

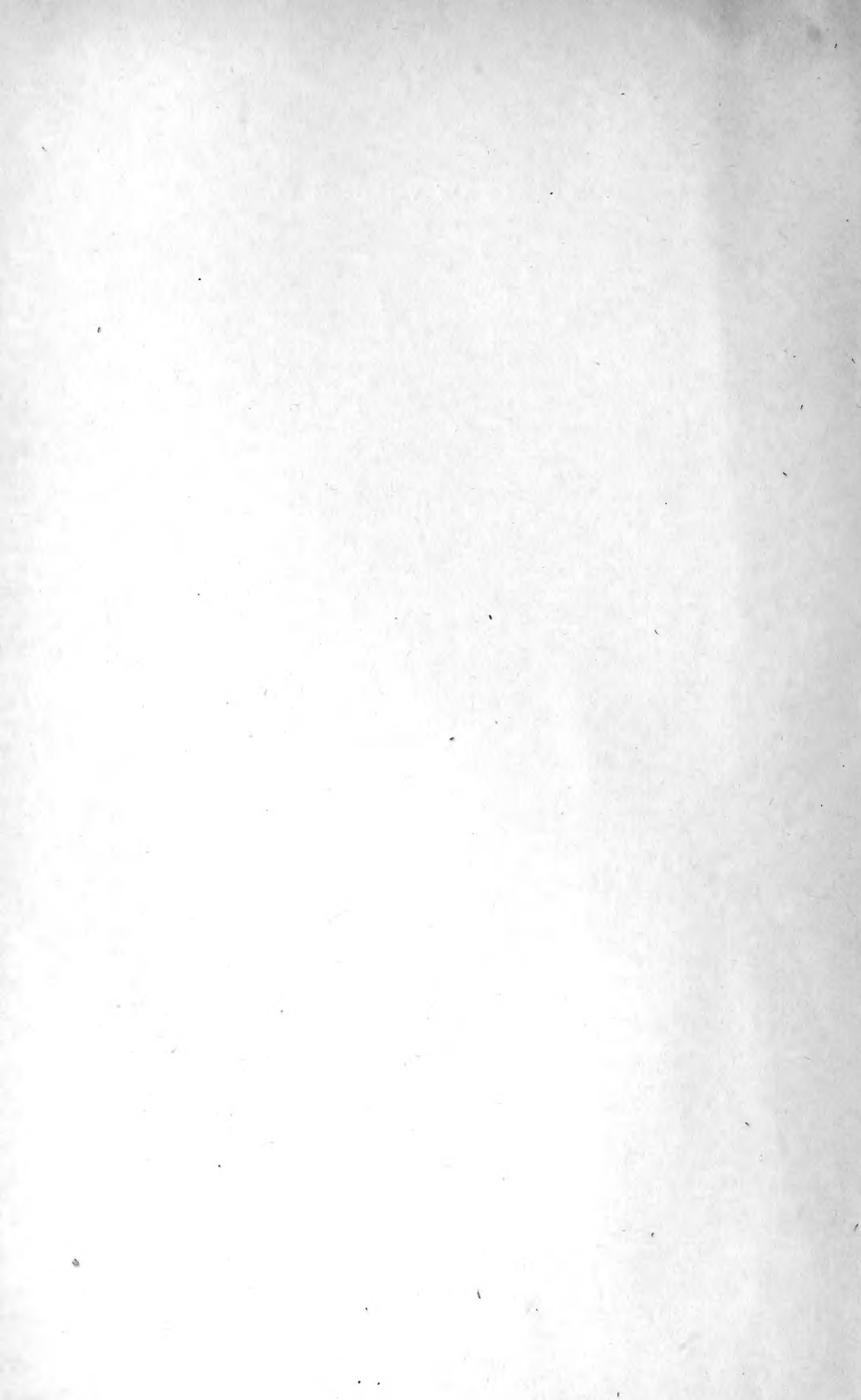

---

---

ANNALS

OF

The Entomological Society of America

---

MARCH, 1913

---

EDITORIAL BOARD

J. H. COMSTOCK,  
ITHACA, N. Y.

L. O. HOWARD,  
WASHINGTON, D. C.

C. J. S. BETHUNE,  
GUELPH, ONTARIO, CANADA.

W. M. WHEELER,  
BOSTON, MASS.

C. W. JOHNSON,  
BOSTON, MASS.

P. P. CALVERT,  
PHILADELPHIA, PA.

V. L. KELLOGG,  
STANFORD UNIV., CAL.

J. W. FOLSOM,  
URBANA, ILLS.

HERBERT OSBORN, Managing Editor,  
COLUMBUS, OHIO.

---

PUBLISHED QUARTERLY BY THE SOCIETY  
COLUMBUS, OHIO

---

---

Entered as second class matter April 11, 1908, at the Post Office at Columbus, Ohio,  
under the Act of Congress of March 3, 1879.



# The Entomological Society of America.

FOUNDED 1906.

## OFFICERS 1913.

*President*—C. J. S. BETHUNE ..... Guelph, Ont., Canada  
*First Vice-President*—P. P. CALVERT ..... Philadelphia, Pennsylvania  
*Second Vice-President*—WM. M. MARSHALL ..... Madison, Wisconsin  
*Secretary-Treasurer*—A. D. MACGILLIVRAY ..... Urbana, Illinois  
*Executive Committee*—THE OFFICERS, and HERBERT OSBORN, C. P. GILLETTE,  
V. L. KELLOGG, J. G. NEEDHAM, C. T. BRUES, NATHAN BANKS.  
*Committee on Nomenclature*—H. T. FERNALD, E. P. FELT, T. D. A. COCKERELL.

## Price List of Publications.

Annals, Vols. I, II, III, IV and V, complete, each.....	\$3.00
Annals, Separate Parts except as below, each.....	1.00
Annals, Vols. I and II, Part 3, each.....	.50
Annals, Vol. IV, Part IV, each.....	1.50

## REPRINTS FROM VOLUME I.

Proceedings of first three meetings; Constitution, By-Laws and List of Members.....	.25
WHEELER, WM. M.—Polymorphism of Ants.....	.30
OSBORN, HERBERT—The Habits of Insects as a Factor in Classification.....	.20
SEVERIN, H. H. AND SEVERIN, H. C.—Anatomical and Histological Studies of the Female Reproductive Organs of the American-Saw Fly, <i>Cimbex Americana</i> , Leach.....	.25
FELT, E. P.—Some Problems in Nomenclature.....	.10
HAMMAR, A. G.—On the Nervous System of the Larva of <i>Corydalis cornuta</i> L.....	.25
BRADLEY, J. C.—A case of Gregarious Sleeping Habits among Aculeate Hymenoptera.....	.10
DAVIS, J. J.—Notes on the Life History of the Leafy Dimorph of the Box-elder Aphid, <i>Chaitophorus negundinis</i> Thos.....	.10
HAMBLETON, J. C.—The Genus <i>Corizus</i> , with a Review of the North and Middle American Species.....	.25
GIRAULT, A. A.—Biological Notes on Colorado Potato Beetle.....	.25
GIRAULT, A. A.—A Monographic Catalogue of the Mymarid Genus <i>Alaptus</i> ..	.25
SEVERIN, H. H. and SEVERIN, H. C.—Internal Organs of Reproduction of Male Saw-fly.....	.15
SMITH, C. P.—A Preliminary Study of the Araneæ Theraphosæ of California..	.75
DAVIS, J. J.—Studies on Aphididæ.....	.20
RILEY, W. A.—Muscle Attachment of Insects.....	.15
NEEDHAM, J. C.—Critical Notes on the Classification of the Corduliinæ (Odonata)..	.15
HOWARD, L. O.—A Key to the Species of <i>Prospaltella</i> with Table of Hosts and Descriptions of Four New Species.....	.15
HOOD, J. D.—Two New Species of <i>Idolothrips</i> .....	.10

Address

ANNALS ENTOMOLOGICAL SOCIETY OF AMERICA,  
Biological Building, State Univ., Columbus, Ohio.

# ANNALS

OF

## The Entomological Society of America

---

Volume VI

MARCH, 1913

Number 1

---

### AN ENTOMOLOGIST IN COSTA RICA.\*

By PHILIP P. CALVERT, Ph. D.,  
University of Pennsylvania, Philadelphia, Pa.

Until the separation of Panama as an independent state from Colombia, Costa Rica was the southernmost of the five republics of Central America. It lies between Nicaragua on the north and Panama on the south, from latitude  $11^{\circ}$  to  $8^{\circ}$  North. Its general trend is from northwest to southeast, and through its entire length runs a series of peaks, many of them volcanoes, whose greatest altitude is above 12,000 feet. North of the 10th parallel, this chain divides into two branches one of which, extending in a more easterly direction toward the Atlantic, is composed chiefly of the volcanoes Poas (8786 ft.), Barba (9508 ft.), Irazu (11326 ft.) and Turrialba (10965 ft.). The other branch, retaining the southeastward trend, is continued by the Cordillera of Chiriqui in Panama and includes the highest elevations in the country. Along the 10th parallel the distance from the Atlantic to the Pacific is 185 miles, but if we measure to the eastern shore of the Gulf of Nicoya, that is from the port of Limon to Puntarenas, 125 miles. The railroad in making this transit climbs to 5000 feet and this ascent together with its windings increases the actual distance to 175 miles.

The prevailing easterly trade winds coming from the Caribbean, laden with moisture, strike against the lofty mountains and cause a heavy precipitation on the Atlantic slope throughout much of the year. Sheltered by the same peaks the Pacific slopes and even some localities on the Atlantic, like Cartago, receive a smaller precipitation until southerly winds bring moisture from April to November.

---

\*Abstract of address before the Entomological Society of America, Cleveland, Ohio, Jan. 1, 1913. The address was illustrated by a very fine series of lantern views from photographs of insects and localities of scientific and scenic interest.—ED.

Passing from east to west, the average annual rainfall at Limon is 126.8 inches, Juan Viñas 85.6, Cartago 60.7, with minimal average monthly precipitations of 5, 2.5 and 1 inch respectively (all these on the Atlantic slope), while corresponding figures on the Pacific slope are 76 inches for Tres Rios, 76.4 for San Jose and 62.1 for Nuestro Amo, the minimal average monthly rainfalls being .12, .43 and 0 inches respectively.

The abundant rainfall gives rise to many streams of all sizes. Erosion and the undermining of the loose soil have cut the surface of the land into many deep ravines and canyons, producing a rugged topography and making travel difficult and time-consuming. Within short horizontal distances are great differences of elevation. This, in turn, has affected the character of the vegetation and of the fauna. Pronounced segregation of many living things is consequently often the case, and the richness of the biota, as estimated by the number of species, is greatly increased.

Pittier, in 1908, gave the number of species of flowering plants of Costa Rica as 3441; the corresponding number for New Jersey is 1351 (Stone, 1910). Carriker, in 1910, listed 753 species and subspecies of birds from Costa Rica, or more than half the total number (1196) for America north of Mexico in the A. O. U. check list of the same year, and twice as many as have been recorded in recent years for Maine (327), Colorado (392) or Washington (372); the smallest of these three has an area at least a third greater than that of Costa Rica which is only 23,000 square miles. Rehn, in 1905, gave a partial list of 195 species of Costa Rican Orthoptera, as against 154 species in the far more thoroughly explored state of New Jersey. Godman and Salvin, in 1901, enumerated 236 genera of Costa Rican butterflies; Dyar, in 1902, recognized 152 genera for America north of Mexico. Schaus has found 150 Costa Rican species of the butterfly genus *Thecla*, as contrasted with 56 species in America north of Mexico.

All of these characteristics make Costa Rica a Paradise to the naturalist. Its variety of altitude offers variety of temperature. The short distance from the shores of the Atlantic to those of the Gulf of Nicoya, an arm of the Pacific, and the existence of the transcontinental railroad render it possible to pass from one to the other in ten hours; a comparison of conditions at similar altitudes on the two slopes of the divide may be easily

and quickly made. In the higher parts of the country the climate is salubrious and invigorating, and with a little care one may safely investigate the heated lowlands. Proximity to South America, with no intervening barrier, has permitted the invasion of many denizens of the Southern Continent, while not a few cases of continuous distribution from North America are also in evidence. The most orderly of Central American countries holds its presidential elections with as much enthusiasm and with less disturbance than those of the United States. A peaceful and hospitable people and an enlightened government render the stranger's visit an event to be remembered by him with delight throughout a lifetime.

In one or other of these qualities, Costa Rica is excelled by Mexico, Colombia or Brazil, but by none in the totality of the advantages which it offers to the students of all the branches of ecology in its widest sense. One shadow, indeed, hangs over the fair land—that of the earthquakes which within two centuries have thrice destroyed the town of Cartago, lying on the southern slopes of the volcano Irazu, the latest destruction being that of May 4, 1910, when it was serving as our own headquarters.

During the year, May 1909, to May, 1910, insects, especially Odonata (dragonflies) were collected and studied at the following fourteen groups of places and at intervals, in order to obtain data on seasonal distribution.

On the Atlantic slope:

Banana River region, 50 feet, November.

Guapiles, 984 feet, June, November.

Peralta, 1088 feet, August, March.

Turrialba, 2000 feet, July.

Juan Viñas, 2500–4000 feet, June, August, October,

December, February, March April.

Cachi, 3600 feet, March.

Cartago, 4750 feet, every month.

Volcano Irazu, 4750–11300 feet, July, September, March.

On the Pacific slope:

Tres Rios and La Carpintera, 4260 to 5700 feet, December, March.

Alajuela, 3100 feet, September, December.

Turrucares, 1800–2200 feet, August, December, April.

Surubres, 800 feet, October.

Puntarenas, 10 feet, February.

Guanacaste, 0–2200 feet, January.

Four of these localities are here described briefly.

Juan Viñas, on the Atlantic slope, was particularly fruitful as a collecting ground owing to its combination of many of the advantages mentioned above. The railroad station, 73 miles from Limon, and at an altitude of 3300 feet, is on the bottom of an old crater the rim of which, at the general level of the country, is 700 feet higher; the village of Juan Viñas is at this latter elevation. From the railway, in half an hour, one may reach the Rio Reventazon, 800 feet below. The canyon of this river thus has a depth of 1500 feet, and presents a great variety of slow- and of swift-flowing brooks, cascades, waterfalls, forest, swamp, bare rock and dense vegetation. It was productive of material illustrating previously unknown life-histories of interesting Odonata (*Cora*, *Mecistogaster*, *Thaumatoneura*, *Philo-genia*, *Palaemnema*, etc.).

Surubres, on the Pacific side, at an altitude of about 800 feet, was a favorite with the late Professor Paul Biolley, where he gathered much insect material subsequently sent to entomologists in the United States and in Europe. A week was spent in the hacienda, which he occupied on several occasions, but at a different time of year, to secure data to supplement those which he obtained.

The northwestern province of Costa Rica, Guanacaste, has been little visited by entomologists. Thanks to Professor J. F. Tristan, the writer accompanied an official educational commission thither, and collections and observations were made at Filadelfia, Liberia, Santa Cruz, and Hacienda Guachipelin. The last named, at an altitude of 1700 feet, is not far from the still unexplored Volcano Rincon de la Vieja.

Cartago, near the top of the Atlantic slope of the railroad, was, until its destruction, alluded to above, a convenient center for visits to various parts of the country and served as the breeding place of living material collected on these excursions.

(Other aspects of this visit to Costa Rica have been described in *Entomological News*, vol. XXI, pp. 334-337, July, 1910, and in *Old Penn Weekly Review of the University of Pennsylvania*, vol. IX, pp. 165-170, Nov. 12, 1910. Some of the results obtained from studies on Costa Rican Odonata have been published in *Entomological News* for 1910, 1911 and 1912, and will probably be continued in subsequent volumes of the same journal.)



# DETERMINING THE FLIGHT OF MOSQUITOS.

By JAMES ZETEK, Entomologist.

Isthmian Canal Commission, Ancon, Canal Zone.

Introduction.

Description.

A. General Considerations.

1. Physical Factors.
2. Biotic Factors.
3. Historic Factors.

B. Detailed Description.

1. Collection and Care of Larvae and Pupae.
  - A. Collection.
  - B. Transportation.
  - C. The field laboratory.
  - D. Breeding-out methods.
2. Care of Adults.
  - A. At the laboratory.
  - B. Transporting adults.
3. Coloring of Adults.
  - A. Anilin dyes used.
  - B. Staining the adults.
4. Liberating Colored Adults.
5. Collection and Examination of Adults found in buildings.
  - A. Collection by hand.
  - B. Collection by traps.
  - C. Collection by tents.
  - D. Collection by sweeping nets.
  - E. Examination of adults for presence of color.

Summary.

Acknowledgements.

References.

## INTRODUCTION.

This report presents a method for determining the flight factors of mosquitos. The scheme was developed and tried out on the canal zone and has given results which warrant its publication. Apart from its purely scientific standpoint, the knowledge of the flight of Culices enables us to direct better our efforts toward the eradication of these insects from our habitations, and thus greatly reduce the possibilities for transmission of such diseases as yellow-fever, malaria, dengue, etc., and to a large measure do away with the insect as a pest.

## DESCRIPTION.

Briefly stated, adult mosquitos are bred, colored with an anilin dye and then liberated at stations about the town selected for study. Systematic collections of adults are made in the buildings of this town, and these adults are tested for the presence of color.

## A. GENERAL CONSIDERATION.

Dispersal includes *everything* involved in the movements of animals from one place to another. It is a more or less eccentric movement because the paths taken are usually those of least resistance and economy. In mosquitos, dispersal is limited to four general means: (1) flight of the adult, (2) the adults may be carried by the wind, (3) they may be carried in trains, other vehicles, on the clothing of man or on other animals, and (4) the eggs, larvæ, pupæ and to some extent the adults, may be carried down stream or across a pond by current or wind action.

Such mosquitos as transmit diseases to man, especially when they serve as intermediary hosts in such transmission, are usually limited in their breeding area to the vicinity of human habitations. This is well illustrated by *Aedes calopus* Meigen which transmits yellow fever, and *Anopheles albimanus* Wiedemann, responsible for E. A. malaria. Such mosquitos (verified by us in the two cited species) are not distant travellers, and if they do come from distant places, it is through gradual infiltration. Some species of *Culex* are powerful fliers; others apparently remain only near their breeding place.

To merely liberate colored adults is almost futile. The study is an ecological one and requires a knowledge of all the physical, biotic and historic factors that in any way enter into the environment of the species studied. The statements given under the three subheads following are not intended to be exhaustive, and they must be amplified according to the species selected.

1. *Physical Factors.*

A good map of the region selected for experimentation is necessary. It must indicate with fair accuracy the topography, commercial projects, habitations, streets, roads, and inlets of oils or poisonous refuse into streams or ponds and the extent of this pollution.

A recording anemometer should be in operation at the central station, and in addition to the velocity per hour intervals, should give the eight main directions. If more than one such instrument is available, the others may be distributed at stations where decided wind deviations take place. Small portable anemometers will greatly augment the data. A self-recording rain gauge is a valuable addition.

The necessity of a well-kept, tabulated record for the data should not have to be mentioned. The following reproduction of an arrangement found satisfactory in our work may be of help to other investigators. This method gives the investigator

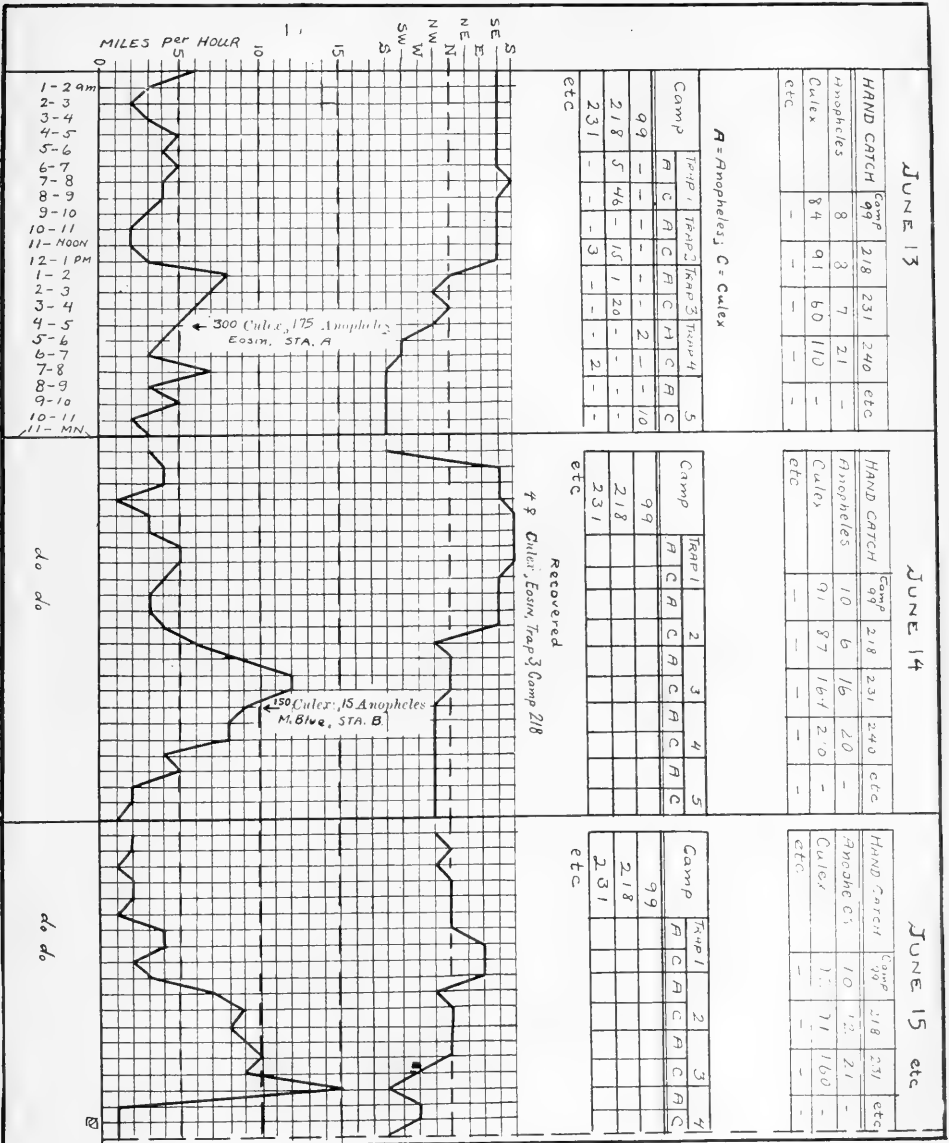

Fig. 1. Correlation Chart.

at a glance four distinct data, graphically placed in proper relation to each other, viz: (1) the velocity and direction of the wind per hour intervals, for six or more days, according to the size of paper used; (2) the quantity, species, and sex of mosquitos liberated, time and place of liberation and the color used; (3) the quantity, species, sex, source and color of recovered adults, and (4) the total mosquito catch in all buildings. A simple system of cross-reference to data sheets containing details will save time and energy.

Tracing cloth, so ruled that the ordinates correspond to the above form, can have recorded thereon the quantity and duration of rainfall, cloudbursts, fogs, barometric pressure, frosts, etc. By superposition on the above tabulated form, the relation, if any, of these factors to flight, will be seen. A similar tracing, made to correspond to the map, should indicate the extent of prairies, forests, forest fires, drainage, marshes, the geology of the region, etc.

Porcelain cup evaporimeters should be installed at many stations to determine the relative humidity.

## 2. *Biotic Factors.*

Weekly or biweekly surveys of the entire area should be made for the purpose of locating mosquito breeding areas. These should be charted on smaller maps. If portions of this area are oiled, treated with larvacides, or subjected to noxious fumes, the extent of such pollution should be clearly indicated on the maps. It is necessary to know the time interval from oviposition to the adults for the species studied. When searching for *Anopheles*, particularly the malaria-transmitter, a safe rule is to go to unfrequented places, small puddles in grass land, etc.

Most mosquitos, particularly the blood-suckers, are most active during and after dusk. It is evident, then, that an investigator should be detailed for night observations. A sweep-net should be used for beating the grass and shrubbery for mosquitos, traps may be set out to intercept or attract adults, or the observer may remain quiet, expose his arm, and note the ferocity of the biting.

The abundance or scarcity of such predacious animals as dragon flies, robber flies, ants, toads, frogs, fish, bats, etc., should be noted. Marked oscillations in the numbers of mos-

quitos will occur through the ravages of these animals. Collections of these forms must be made and the stomachs examined. The best time for such collection is at or just after dusk when they feed upon these dainty morsels. Unless the stomachs are examined that evening, they should be preserved in 95% alcohol, containing about one percent of thymol, the latter to arrest enzymic action.

Life history studies should be made at the laboratory and all possible data bearing on the ecological problem collected.

### 3. *Historic Factors.*

This includes the geology of the region, the plant and animal association and their past history and present trend, past human disturbances still exerting an influence on the biota, and the past history of the mosquitos studied.

## B. DETAILED DESCRIPTION.

Mosquitos are delicate organisms, the majority of the species unable to endure intense dry heat, absence of water or shelter, high winds, heavy rains, etc. They are dainty morsels to hosts of alert forms. So far as our experiments are concerned, additional factors enter to lessen the number of released adults which may be recovered. First, the female almost exclusively is able to suck blood. Second, mosquitos are not dependant upon human blood alone. We have noted mosquitos sucking the blood of horses, mules, dogs, cats, monkeys and fowls. The need, then, for releasing large numbers of colored adults is evident. Better results will follow if thousands of mosquitos are liberated.

### 1. *Collection and Care of Larvæ and Pupæ.*

*A. Collection:* Mature or nearly mature larvæ and all pupæ, of the species selected for study, should be collected. Young larvæ thrive poorly in the field laboratory. All predacious larvæ must be excluded from the receptacles containing larvæ and pupæ.

A white enameled or porcelain saucer is very satisfactory in "dishing-up" water and algæ to note whether mosquito larvæ are present. The larvæ, if there, stand out in bold relief against the white back-ground. If the larvæ and pupæ are abundant, a large white enameled dressing bucket (such as is used by hospitals) should be used to dip up quantities of the

water and algæ. This prevents frequent disturbance of the water, and allows the frightened mosquitos to regain their equilibrium. When dishing-up the water, a shadow should not pass over the surface of the pond, as this causes the larvæ to wriggle away. The algæ in the bucket should be removed after the larvæ clinging to them have been dislodged. The contents of the bucket may then be strained through a clean piece of surgical gauze. In this manner the larvæ and pupæ are not lost, while the very young larvæ, small debris, etc., are allowed to wash into the pond or stream. The gauze should be inverted over a wide-mouthed jar, and water applied very carefully with a pipette to the larvæ. These are thereby released from the gauze and placed in the jars. Small pails are as servicable as jars.

The receptacles containing the larvæ and pupæ must be kept in a cool, shaded spot, otherwise the water will quickly foul. Not more than one and a half inches of water should be allowed in these jars. The larvæ should not be left in these containers for more than one half a day. Overcrowding must be avoided and at least once each half day the water should be aerated. A Paquelin Cautery bulb, with a capillary tube attached, serves well this object, and one or two bulbfuls will be found ample.

*B. Transportation:* The larvæ in these wide-mouthed jars should be taken each half day to the field laboratory, and here emptied into plates or larger receptacles. Prior to transportation, the jars should be placed into a basket and separated from each other with excelsior or cotton wadding, and while carried, shaking must be reduced to a minimum. Constant shaking prevents the larvæ from reaching the surface of the water to breathe and hence repeated unsuccessful attempts to reach the surface bring fatigue and a large percent if not all of the larvæ succumb as a result. Protection from heat and direct light must be considered. The jars themselves must be covered with a close-mesh gauze to prevent the escape of adults emerged en route. If larvæ or pupæ are transported in trains or vehicles, extra precaution should be taken regarding shaking, and additional precaution to prevent inquisitive people from handling these jars and shaking them "to see the wrigglers wriggle,"

Mosquito larvæ and pupæ must be considered as delicate organisms and rough treatment en route makes nil the whole day's work and gives but little encouragement for further work.

*C. The Field Laboratory:* The field laboratory is a necessity, but it need not consist of more than a small screened house, about eight feet square, protected from direct sunlight and heat. If located convenient to the breeding places, the collected larvæ will suffer but little from jarring en route. Several such houses may be erected at convenient places, however, for all purposes one such house will suffice. It means a concentration of the collected larvæ at one place and one attendant can give these his undivided attention. No staining of adults should be made at the laboratory as this would involve transferring of colored adults and the possible escape en route of some of these.

*D. Breeding-out Methods:* As soon as the larvæ and pupæ in the wide-mouthed carrying jars reach the field laboratory, they should be transferred into a large pan. The pupæ should be picked out by means of a pipette and confined in jars, these covered with gauze.

White enameled or porcelain soup plates gave the best results as breeding receptacles for the larvæ. If the plates are tilted slightly, both shallow and deep water is afforded to the larvæ. Debris and filamentous algæ should be reduced to a minimum. The food of the larvæ should be known; if diatomaceous, a few pebbles covered with diatoms will suffice. Predacious larvæ of all sorts must be eliminated. Some species of mosquitos prefer sunlight, others do not, or there is preference for foul water, etc. These peculiarities must be known. *Successful breeding depends upon a careful attendance to the peculiar environmental factors of each species.*

Unless the water in the dishes is changed weekly, fouling will ensue and cause heavy mortality. This is obviated by pouring the contents of the dishes over a piece of clean surgical gauze and then inverting over a clean plate containing fresh water. The larvæ when in contact with the water will free themselves from the meshes of the cloth. Sudden additions of fresh water were found to be detrimental; best results were obtained with water which had been standing in the room for twenty-four hours. Careful observance to these environmental requirements has reduced mortality among our own larvæ from ten percent to less than one percent.

The water in the breeding dishes must be aerated twice daily. The Paquelin Cautery bulb method referred to on page 10 does well when the number of places is few. When these plates are numerous, it is better to construct an aerating device such as shown in figure 2, using old tins, tubing, etc. There

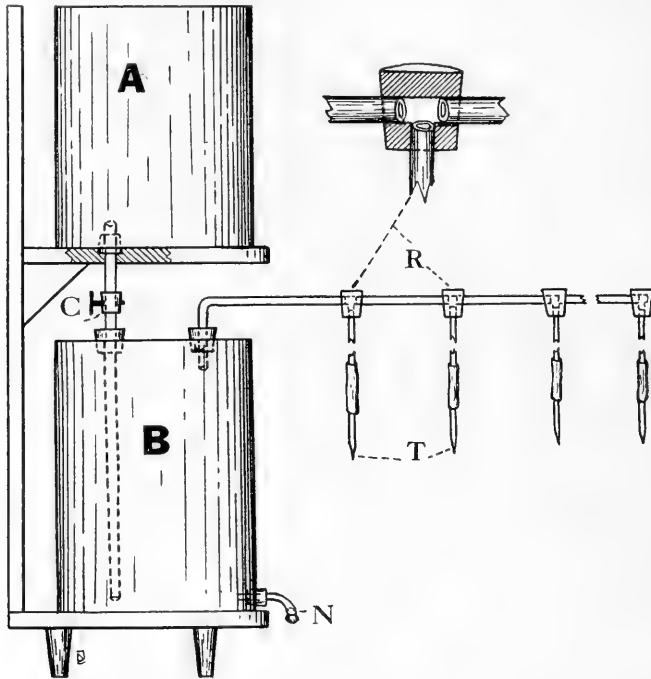

Fig. 2. *Aerating Device.* A, water reservoir, open at top; B, air chamber; C, stop-cock regulating flow of water into B; R, tee unions made of cork; T, terminal capillary tubes.

should be as many feeders as there are dishes to aerate. To set the apparatus into operation, adjust feeders to plates, fill chamber "A" with water and open stop-cock leading to the air chamber.

The writer noted on four occasions a large roach drinking water from breeding pans, at the same time devouring larvæ. On seven occasions ants were seen reaching after such larvæ as were near the edge of the plates and while under observation, two larvæ were successfully withdrawn from the water. These observations suggest strongly the need of protection against these inroads. Keep lookout for mice.



Frequently through chemical or physical changes in the water, produced by excess of heat or food, improper food or foreign substances, waste, etc., the larvæ become sluggish and pupation is greatly retarded. If the cause is not due to fouling of the water, then table salt added not in excess of three percent, will make the larvæ active and accelerate pupation. The dead or sick larvæ in such pans should be eliminated.

Pupæ should be segregated from the breeding dishes daily, preferably morning and evening. They should be confined in wide-mouthed jars, the depth of water not exceeding one and one half inches, and the number of pupæ not more than two hundred and fifty. The mouths of these jars should be provided with paper cones, the tip truncated, and both cone and neck of the jar inserted into a screen cage as shown in figure 3.

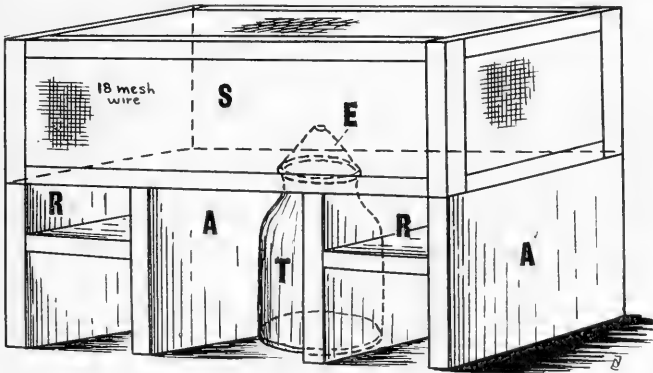

Fig. 3. *Breeding-out Cage.* S, screen cage, hinged back; A, wooden "H" supports; R, lofts for wetted waste; T, jar containing pupae; E, truncated paper cone trap.

The cone acts as a trap, thus preventing the adults which enter the cage from returning into the jar and being drowned. All crevices about the jars and in the cages must be stopped with cotton waste.

It is advisable to place moist cotton on the floor of the screen cage, also to fill cavities "A" of the "H" supports with wet waste. The top ought to be covered with a wet cloth. These simple measures keep the inside of the cage cool and sweet, and adults can be kept in good condition for at least six days. The cages must be protected from direct sunlight, heat and rain. If ants are present, isolation by water barriers is necessary.

Several times the writer noted roaches in the cages, and the crops of the dissected roaches, as well as the appearance of the adults in the cages, showed the "why" of their presence.

### 2. *The Care of Adults.*

*A. At the Field Laboratory:* It is necessary each morning to remove the jars containing pupæ from the screen cages. It will be found that no few adults remain on the sides of the glass jars. These are readily transferred into the screen cage by holding the cage in direct sunlight and tapping the jar briskly with the hand. When the jars are removed, the holes in the cage which served to receive them, must be plugged snugly with cotton waste to prevent the escape of any adults. The cage must now be placed in a sheltered corner and left for several hours, or until the chitinous portions of the exoskeleton have hardened and the wings stiffened. Precaution must be taken against the invasions by ants and roaches. Avoid rapid evaporation and direct sunlight.

*B. Transporting Adults to Stations:* Colored adults should not be carried to several localities, the danger of the accidental escape of a colored one en route being too great. Adults, unstained, are best transported in the morning or evening, and each cage should be securely closed and partly encased in a damp cloth. The uncovered side should be underneath. An oil cloth cover is necessary during showers. In two instances, when no covers were used, and the cages carried through light showers, all the adults were killed. Protection from wind was found necessary. Air currents cause rapid evaporation which the mosquitos cannot withstand.

### 3. *Coloring of the Adults.*

*A. Dyes Used:* Aqueous solution of eosin, fuchsin, gentian-violet, bismarck-braun, methylene-blue and orange-g, were used with good success, the proportions of dry stain to water being about one gram to fifty cc. It is best to make small quantities at a time as stock solutions may deteriorate. All stains should be kept locked up. Likewise staining operations should be known only to a few. Curiosity too frequently gives birth to trouble.

It may not be amiss to state under this section two other "markers" which may be used effectively with larger diptera. In our work they were not as serviceable as the dyes. The

first is a 1 : 20 aqueous solution of phenolphthalein. It was found satisfactory on typhoid flies and is detected readily when a drop or two of one percent solution of ammonium or sodium hydroxide is added to the suspected specimen. A deep red color indicates presence of the drug. The second agent is corn starch and it is detected by applying tincture of iodine, a purple color ensuing in its presence. We had no opportunity to give this latter method a fair trial.

*B. Staining the Adults:* The mosquitos in the rectangular screen cages should be stained preferably toward evening, about two hours before they are to be released, and always at the station where they will be liberated. A shelter must be provided for these cages. The stains must be applied lightly and must be dry on the insects before they may be allowed freedom. Small globules of water on the wings weight these down to such an extent that the mosquito cannot fly, and it is then easily captured by ants, roaches or more alert forms.

The aqueous solution of the anilin dyes is converted unto a very fine spray through a vaseline-nebulizer, or a fine atomizer, and this spray is allowed to *fall* upon the mosquitos. Direct and forceful projection of the stain against the sides of the mosquito is productive only of death to the insects. Too concentrated solutions must be avoided. The idea is not to encrust the mosquito with the stain, but to place a minute speck only upon the body. Hundreds of tests, using mere specks of the stain gave perfect results when tested for color. The danger of too-protracted a staining is that spiracles become sealed with the stain, mouth parts glued together, sensory areas covered, wings folded, etc.; in other words the mosquitos are no good.

After the mosquitos have been liberated, the cage should be washed in clear water to dissolve all superfluous stain adhering to the screening or sides of the cage. Such crusts, if allowed to remain, create a foulness about the cage which is detrimental to the mosquitos confined therein. It is best, though the statement seems hardly necessary, to keep separate cages for each color used.

To remove stains from fingers and hands, received during the coloring operations, wash hands in acid alcohol. The best way is to use rubber post-mortum gloves when staining mosquitos.

#### 4. *Liberating Colored Adults.*

The experiments conducted on the canal zone suggest the advisability of liberating adults at or about dusk, or from then on till midnight. The stations selected may be few or many, depending upon the complexity of the physical and biotic factors presented at the time. All that is necessary for liberation is for someone to open the lid of the cage containing the colored mosquitos. This observer should note the time when he liberated the mosquitos, the climatic conditions at the time, and the direction taken by the mosquitos. If people move about near the place of liberation, particularly after dusk, and go to the town from there, this should be carefully noted. The person delegated for this duty should be a keen observer, and honest, too.

The habits of the mosquitos vary with the species—not all cry for the warm blood of man. Then there are some that can't be without it. The writer liberated in the bush, about one quarter miles from Corozal, Canal Zone, at eleven a. m., about fifty stained *Anopheles albimanus* Wiede., and noted three of these soon clinging to his dark colored trousers, and by walking slowly—just as the natives do—he brought these with him into the town of Corozal. This illustrates one of the avenues of dispersal, practically independant of wind, and we must reckon with it, especially since this species is responsible for most of the malaria on the canal zone.

A precaution, based on the above observation, was found necessary. *Brush your clothing* carefully after liberating colored mosquitos, and if possible, *wear a light colored suit*. The latter suggestion proved very helpful. Note also if people passing along the highways, walk toward or from the townsite, and whether they saunter or walk fast, or are quiet or boisterous.

#### 5. *Collection and Examination of Adults in Buildings.*

The recovery of liberated mosquitos in the buildings will demand thorough search and great precaution. Unless this is done, much fruit cannot be expected for the labors and patience expended.

*A. Collection by Hand:* Hand collections in the buildings are best made at dawn and just at dusk, the mosquitos at these two periods trying to get out and into, respectively, of the

buildings. The men selected for this work should be provided with a killing-tube made of a heavy walled test tube, 6 inches by  $1\frac{1}{4}$  inches, containing a four inch cotton plug saturated with chloroform, over which are a few circular pieces of blotter paper. The collector merely superimposes the mouth of his tube over the mosquito he sees on the wall or clothing, the chloroform vapor, readily generated by the aid of the heat of his palm, quickly kills the insect. A few days' work will render the novice an expert. All the mosquitos caught in one day in one building should be placed by the collector into a circular pill box, of which he should have a good supply. This box should be labeled, giving the date, house, and the initials of collector. At the close of day, these boxes should be turned over to the person in charge, who should check them and rectify any existing errors. The next step is to examine these captured mosquitos for color. (See pp. 19-20).

*B. Collection by Traps:* If the buildings are *well-screened* and holes and crevices blocked, mosquito traps may be used to excellent advantage. This is being done on the canal zone,

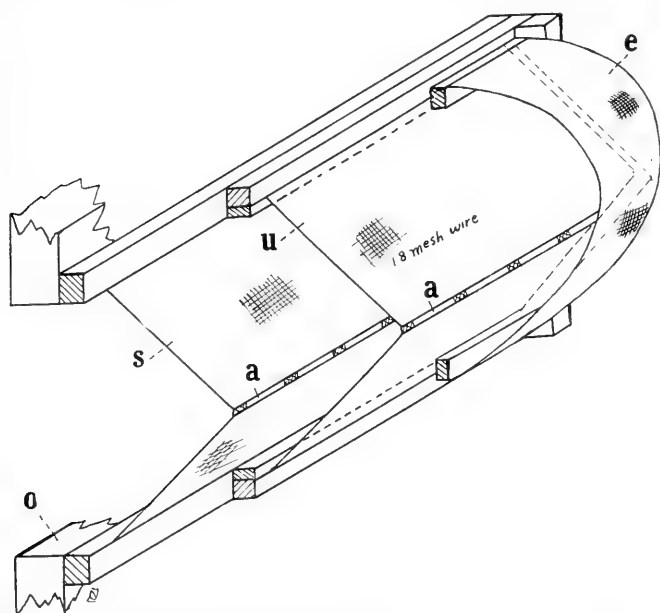

Fig. 4. *Mosquito trap*, in section. *s*, inner "V" section; *u*, middle "V" section; *a*, slits in the "V" sections; *e*, semicircular outer envelope; *o*, sill of building. The "V" sections are detachable.

and the trap illustrated was developed by Mr. Chas. H. Bath, sanitary inspector. Such or similar traps greatly add to the data, and if placed to buildings that harbor a large number of people asleep, will attract many mosquitos, save them, and in regions of malaria, greatly reduce the number of such cases. The traps should be numbered and recorded on charts where their location with respect to the wind is seen at a glance.

Traps should be taken down each morning, at about nine o'clock was found best, and the adults in these killed and placed into pill-boxes, one box for each trap, and each box properly labeled. There is no apparent need for blocking up the opening in the wall when the traps are removed. During five months with these traps, the writer never found a single mosquito that entered during the daytime. The method used was to place a new trap in the place of the one taken out.

A very satisfactory and quick way to kill the mosquitos in the traps is to place the trap into a closed chamber and fumigate with sulphur dioxide. The question arises whether or not this gas combines with the moisture in the mosquito to form sulphurous acid ( $H_2SO_3$ ), and whether or not this will bleach what color is on the mosquitos. The data following, of a series of tests made, indicate the negative is true:

50 *Culex* sp. Stained lightly with eosin, left in  $SO_2$  chamber for 3 hrs.; no bleaching.

100 *Culex* sp. Stained lightly with eosin; 100 *Culex* sp. with gentian-violet, exposed 13 hrs.; no bleaching.

30 *Culex*, 70 *Anopheles albimanus* et *malefactor* stained lightly with methylene-blue, exposed to burning sulphur and generated steam for  $3\frac{1}{2}$  hrs.; O. K.

10 *Culex* sp. each slightly stained with all stains cited, exposed 15 minutes; no bleaching.

Paper and blotters, wetted and colored, exposed for 6 hrs.; no bleaching; no acid reaction to litmus.

Vials containing 1 : 10000 aqueous solutions of bismarck-braun, methylene-blue, gentian-violet and eosin, exposed  $3\frac{1}{2}$  hrs.; no bleaching; no acid reaction.

*C. Collection in Tents.* If patient and honest men are procurable, army tents may be pitched at suitable places radiating from the releasing point, and these men placed, one to a tent, with a lantern, killing tube and boxes, to catch all mosquitos that enter the tent. The lamp should burn dimly,

and the men cautioned to be as quiet as possible, and if they must move about, to so do with little commotion. Contrary behavior shews mosquitos away. It seems these gnats wait at the door till the occupant is quiet. The mosquitos caught in a given tent during each hour interval, should be placed in a pill-box, and this one properly labeled, containing in addition to what had already been indicated, the particular hour's catch represented.

*D. Collections with a Beating Net:* Important clues bearing directly upon the movements of adult mosquitos will be obtained by systematic sweeping in the grass and shrubbery, using for this purpose a large entomological beating net. The adults thus captured should be placed into pill-boxes, these labeled to show the place where caught, character of the vegetation, and hour when captured. The note book should contain data concerning the temperature, wind direction, velocity, humidity, cloudiness, smoke, etc. The writer noted from a series of sweepings that *Anopheles albimanus* Wiede. and certain Culices (*C. quinquefasciatus* Say et *Mansonia titillans* Walker) were more abundant in the grass when the winds were above four miles per hour, than when these winds were less. Its bearing upon the problem can only be determined after a series of careful tests.

*E. Examination of Adults:* The mosquitos in a single pill-box should be emptied upon a piece of glass plate under which is a white blotter or paper. With a camel's hair brush these are spread over the plate and each specimen is wetted with a testing solution containing three parts of glycerine, three of alcohol and one of chloroform. If any color is present upon any mosquito, it will be revealed as soon as the testing solution reaches it, diffusing outward. Thus each colored specimen becomes a distinct nucleus of diffusion—hence non-colored adults cannot receive through accident some of the diffusing color and thus confuse the observer. The number, species, sex, date and where captured, of all recovered mosquitos, should appear on the data sheets and charts. In addition, a record should be kept of the total mosquito catch, properly tabulated.

It is advisable that only one person be detailed for this examination, and care must be exercised to select a man free from either amnesic or general color blindness. His working table must be kept clean. He should make preliminary tests

to note the action and peculiarity of each color when tested. Accidental rupture of the abdomen of a mosquito, thus extruding the contained blood, should cause no confusion as this blood does not diffuse as does a stain, and furthermore, after a few minutes in the solution, it turns brown. If a spectroscope is available, all colors recovered should be confirmed. As a precaution, all tested mosquitos should be destroyed daily. It is advisable that each day's catch be examined as soon as possible, and whenever delay is necessary, afford protection from ants.

#### SUMMARY.

1. It is essential, first of all, to have a good map of the territory, to keep a record of climatic conditions, to know the topography and plant associations, the species of mosquitos studied, etc.

2. Larvæ and pupæ must be collected in large numbers, cared for at a field laboratory and the adults that emerge kept in first class condition until ready to be colored and released.

3. These adults must be stained lightly and carefully, without injury to the insect, and the stain allowed to dry on the mosquitos before they are released. Color at liberating station.

4. Release the adults, noting conditions under which this is done. Brush your clothing.

5. Collect daily as with a fine comb, the mosquitos that entered the buildings, tents, and traps. Test these for any color present.

6. *Lastly, interpret rightly your results.*

#### ACKNOWLEDGMENTS.

The writer is particularly indebted to Colonel W. C. Gorgas, Chief Sanitary Officer, Isthmian Canal Commission, for permission to contribute and publish this paper.

He also extends his gratitude to the following gentlemen who favored him in many ways: Mr. J. A. Le Prince, Chief Sanitary Inspector; Dr. A. J. Orenstein, Assistant Chief Sanitary Inspector; Dr. S. T. Darling, Chief, Board of Health Laboratory, Ancon Hospital; Messrs. A. R. Proctor, C. H. Bath, J. B. Shropshire, W. S. Chidester and Geo. Parker, Sanitary Inspectors.



## REFERENCES.

The titles appearing below will aid the experimenter mainly by giving the taxonomy and behavior of mosquitos.

- DARLING, DR. S. T. 1910. *Studies in Relation to Malaria*. Isthmian Canal Commission, Washington, D. C. This report contains important observations upon the habits, habitats and control of *Anopheles* spp.
- DYAR, HARR. G., and KNAB, FRED. 1906. *The Larvae of Culicidae Classified as Independent Organisms*. Journ. N. Y. Ento. Soc., Vol. XIV, No. 4. Particularly helpful in separating the larvae.
- GILES, G. M. 1906. *A Handbook of the Gnats or Mosquitos*. N. Y. Wm. Wood & Co.
- HOWARD, DR. L. O. 1902. *Mosquitos*. McClure Phillips & Co., N. Y.  
1906. *Key to the Known Larvae of Mosquitos of the United States*. U. S. Dept. Agric. Bur. Ento. Circ. 72. Washington, D. C.
- KNAB, FRED. - See Dyar Harr. G. and Knab, Fred. 1906.
- LEPRINCE, J. A. 1909. *Mosquito Destruction in the Tropics*. Journ. Am. Med. Asso. Vol. LI., pp. 2203-2208. A good summary to date of anti-malarial work on the Zone, and containing valuable data concerning the habits of *Anopheles* spp.
- ORENSTEIN, DR. A. J. 1912. *Sanitary Inspection of the Canal Zone*. Am. Journ. Public Health. Mar., '12.

A REVISION OF THE NORTH AMERICAN SPECIES OF  
THE DIPTEROUS GENUS NEURIGONA.  
(DOLICHOPODIDÆ.)

M. C. VAN DUZEE.

The Dipterous genus *Neurigona* was established by Rondani in Dipt. Ital. prodromus in 1856, with one species, *quadrifasciata* Fabr., which is therefore the type of the genus. In 1829 Thomas Say described an American species as *Medeterus lateralis*. Dr. Loew in 1864 published three others, *dimidiata*, *rubella*, and *tenuis*, and in 1869 a fourth, *carbonifer*. In 1899 W. M. Wheeler added two more, *floridula* and *lienosa*, thus giving us seven described species from America north of Mexico. From farther south Prof. Aldrich has described *decora* and *signifer* from Grenada and St. Vincent, and J. R. Schiner has given us *brasiliensis* from Brazil. These are all the species previously described from America so far as I can learn.

The genus *Neurigona* as characterized by Dr. Loew under the name *Saucropus* in his Monograph of the Dolichopodidæ of North America are:

"First joint of the antennæ without hair on the upper side; arista dorsal; thorax with a sloping area upon the middle of its posterior end; feet very long and slender; hind tibiæ elongated, the first joint of hind tarsi without bristles, shorter than the second; abdomen elongated and narrow, especially in the male; hypopygium disengaged, short and stout, inflected, with short very little developed appendages; color of the body principally or at least partially yellow; hairs and bristles mostly black."

The above characters serve to define the genus as I use it in the present paper but there are some exceptions that should be noted. The bristles of the dorsum of the thorax are always black, thus separating the species of this genus from those of the genus *Chrysotimus* where they are yellow, but those of the abdomen are often pale as are also the hairs especially in the male. There is a group of western species which are entirely or almost entirely blackish; the first joint of the hind tarsi is sometimes longer than the second, as is the case in *superbiens* Loew, which is synonymous with *lateralis* Say, and fully as long in the male of *tenuis* Loew, also longer in *australis* n. sp.

In the table of genera of the Dolichopodidæ in Williston's Manual of the North American Diptera under No. 28 we have to take fourth vein converging towards the third in order to

run a specimen through to the genus *Neurigona*. In most of our species this is true but there are several exceptions. Dr. Loew in his Monograph of the Dolichopodidæ says that in the South African species the third and fourth veins are parallel, which is also the case with *N. signifer* Aldrich, and in one or two of the species described in this paper. I might add that the abdomen of the female is prolonged into more or less of an ovipositor, as this character is of importance in separating this genus from *Xanthochlorus* where the female abdomen is blunt or rounded at the tip.

Fred Kowarz in Wiener Entomologische Zeitung, II, p. 51, uses the following characters in taking a specimen through to the genus *Neurigona*: "Acrostichal bristles present, in two rows; Arista dorsal; Fourth longitudinal vein not forked; hind coxæ with a single erect bristle on the outside; body color not metallic." These characters hold good in all of the species included in this paper that I have seen except that in *N. albospinosa* n. sp. there are several weak and one stronger bristle on the outside of the hind coxæ; and the last character given would have to be used in a qualified sense.

There are a few characters which are common to most if not all of our species: The lateral and lower orbital cilia are always pale, as are also the cilia of the tegulæ. The hind coxæ have a single large black bristle on the outside, except in *albospinosa* n. sp. which has one large and several weaker whitish bristles on the outside of the hind coxæ. There are two large black bristles on the margin of the scutellum, and in most of our species there is a pair of weak bristles or hairs outside of these. In all of our species that I have examined, and in the two European species that I have seen, (*4-fasciata* Fab. and *suturalis* Fall.), there are one or more pale yellowish bristles above the front coxæ; and often a black bristle on the middle and hind trochanters. The hairs on the legs are arranged in longitudinal rows, and the lower surface of the femora are usually bare. The males of many of our species have a ventral extension of the fifth segment of the abdomen into which the hypopygium partly fits when bent under the abdomen as it is ordinarily carried, I have called these extensions sheaths, they are bilobed, and form characters that can sometimes be used in separating the species.

Most of our species of *Neurigona* are found on the trunks of trees but I sometimes take specimens, mostly of the *rubella* group, while sweeping. In most cases these insects will fly to a tree and alight instantly and rest in one position until they are disturbed or wish to change their location when they make a quick short flight alighting generally a little distance higher up or sometimes to one side, seldom or never lower down. I have often seen them start near the ground and work upwards in short flights until they disappeared from view at a height of perhaps eighteen feet. The male often comes to a tree and flies upward in a perfectly vertical line about two inches from the trunk until it disappears from sight or alights about twelve feet or more above the ground; it may be looking for the female or possibly seeking its prey. In several instances I have seen individuals feeding on Psocid larva.

I have watched the courtship of the males a number of times, they hover over the female for a few seconds and then try and alight upon her, but only once did I see the union consummated, in all other cases the female darted away.

As far as I can learn the only species in our fauna that has been bred is *N. viridis* n. sp. Mr. James Angus, of West Farms, N. Y., makes the following note on this species: "Larva feeding in rotten wood of hickory." We have no description of this larva or pupa, but a pupa case is mounted with Mr. Angus' specimen in the National Museum collection.

The sexes of this genus seem to be unevenly distributed. At one time I will take nearly all males, at another mostly females. One afternoon I took seven males and thirty-five females of *tenuis*, while the next morning in woods a mile and a half distant I took twenty-two males and but nine females of the same species. At another time I took fourteen males of *floridula* var. *infuscata* and no female, but with them were several males and females of *deformis* n. sp. At another time I took many males of *tarsalis* in one spot with females of two other species, and a half mile farther on found both males and females.

The drawings for this paper were made with a camera lucida by Mr. William Wild, of East Aurora, N. Y. The drawings of the hypopygiums give a good idea of the general appearance but no attempt was made to go into anatomical details.

I wish to acknowledge my indebtedness to those who have sent me material for study, and thereby made the revision of this genus possible. To Prof. J. M. Aldrich for the loan of his material, and his help during the preparation of this paper; to the authorities of the National Museum for the loan of specimens, and to Mr. Knab for his help in looking up references in the National Museum library; to Mr. Nathan Banks, Prof. C. W. Johnson, Prof. A. L. Melander, and Mr. V. A. E. Daecke, for the loan of their material; and to Mr. E. T. Cresson for the loan of the material of the American Entomological Society.

## TABLE OF SPECIES.

## MALES.

1.	Dorsum of the thorax mostly black, green or blue	2
	Dorsum largely yellow	17
2.	Hypopygium yellow	3
	Hypopygium black or testaceous	7
3.	Dorsum of the thorax bright blue. (West Indies)	16 <i>decora</i>
	Dorsum black or greenish	4
4.	Abdomen with black bands	5
	Abdomen marked with green	6
5.	Front tibiæ with a row of bristles above, front tarsi plain	27 <i>tibialis</i>
	Front tibiæ plain, third joint of front tarsi white, fourth and fifth joints black	23 <i>tarsalis</i>
6.	Abdomen marked with brilliant green, appendages of the hypopygium small. (Eastern species)	25 <i>lateralis</i>
	Abdomen marked with darker green, appendages long, well developed. (Western species)	26 <i>setosa</i>
7.	Abdomen yellow with black bands	8
	Abdomen nearly uniform, color blackish	15
8.	Costa strongly arcuated. (Figs. 17 and 18)	9
	Costa normal	10
9.	Front tarsi with the second, third and fourth joints flattened and fringed with hairs	18 <i>deformis</i>
	Front tarsal joints not flattened, fifth black and bent at a right angle	17 <i>arcuata</i>
10.	Thorax bright shining green	15 <i>viridis</i>
	Thorax if green dull	11
11.	Front tarsi plain	14
	Front tarsi ornamented	12
12.	Front tarsi black, fringed on each side with short hairs	28 <i>ciliata</i>
	Front tarsi with an oval tip	13
13.	Front tarsi two-thirds as long as their tibiæ	20 <i>pectoralis</i>
	Front tarsi about as long as their tibiæ	19 <i>tenuis</i>
14.	Pluræ and dorsum blackish	21 <i>aestiva</i>
	Pluræ and sides of dorsum yellow, most of dorsum black and polished	5 <i>nitida</i>
15.	Front tarsi plain	31 <i>albospinosa</i>
	Front tarsi with an oval tip	16
16.	Front tibiæ longer than their tarsi	29 <i>perbrevis</i>
	Front tibiæ shorter than their tarsi	30 <i>australis</i>
17.	Front tarsi ornamented	18
	Front tarsi plain	19
18.	Front tarsi with an oval tip	4 <i>carbonifer</i>
	Front tarsi with the second joint flattened and widened at the tip, other joints cylindrical	12 <i>aldrichii</i>

19.	Abdomen yellow with black bands.....	22
	Abdomen yellow without black bands.....	20
20.	Fourth joint of front tarsi nearly two-thirds as long as third, last four joints infuscated.....	14 <i>disjuncta</i>
	Fourth joint only about one-third as long as third, fifth joint black.....	21
21.	Wings hyaline, tinged with yellow, veins yellow.....	9 <i>floridula</i>
	Wings with a cloud at tip, tinted with brownish, veins brownish.....	10 <i>floridula</i> var. <i>infuscata</i>
22.	Dorsum of the thorax with the flattened space before the scutellum yellow.....	23
	Dorsum with the flattened space blue or black.....	24
23.	Dorsum of the thorax yellow, immaculate.....	14 <i>disjuncta</i>
	Dorsum with two or three black spots.....	8 <i>maculata</i>
24.	Flattened space before the scutellum a beautiful greenish blue (West Indies).....	7 <i>signifer</i>
	Flattened space black.....	25
25.	All the hairs and bristles of the front and middle coxæ yellow.....	3 <i>dimidiata</i>
	Hairs and bristles of the middle coxæ mostly black.....	26
26.	Front tibiæ with a row of bristles.....	27 <i>tibialis</i>
	Front tibiæ plain.....	27
27.	Front metatarsi about one and one-fourth times as long as their tibiæ.....	1 <i>rubella</i>
	Front metatarsi about equal to their tibiæ.....	2 <i>perplexa</i>

## FEMALES.

1.	Dorsum of the thorax largely yellow.....	16
	Dorsum mostly blue, green, or blackish.....	2
2.	Dorsum of the thorax bright shining blue. (West Indies).....	3 <i>decora</i>
	Dorsum green or blackish.....	3
3.	Dorsum bright shining green.....	15 <i>viridis</i>
	Dorsum dull greenish or blackish.....	4
4.	Dorsum dull greenish.....	5
	Dorsum black or gray.....	14
5.	Tip of the fourth vein ending distinctly before the apex of the wing.....	6
	Tip of the fourth vein ending in the tip of the wing, or nearly so.....	7
6.	Tergum of the last two segments of the abdomen dull green, middle and hind femora each with a bristle near the tip.....	26 <i>setosa</i>
	Tergum with more or less brilliant green, femora without a bristle near the tip.....	25 <i>lateralis</i>
7.	Abdomen fasciate.....	9
	Abdomen of nearly uniform color.....	8
8.	Large species, 4.5 mm. (New Mexico).....	30 <i>australis</i>
	Smaller species, 2 mm. (Eastern species).....	32 <i>minuta</i>
9.	Wings strongly tinged with yellow on the costal edge.....	10
	Wings nearly uniform grayish hyaline.....	11
10.	Wings with distinct clouds at the tips of third and fourth veins.....	18 <i>deformis</i>
	Wings evenly tinged along the front, not darker at tip.....	17 <i>arcuata</i>
11.	Dorsum of the thorax covered with brown pollen which nearly hides the ground-color. (Calif.).....	24 <i>lienosa</i>
	Dorsum with grayish, or white pollen.....	12
12.	Pleurae and dorsum without yellow, except the humeri and sometimes the lateral edges and posterior angles.....	13
	Pleurae and dorsum with considerable yellow.....	19 <i>tenuis</i>
13.	Pleurae and dorsum without yellow except the humeri.....	20 <i>pectoralis</i>
	Dorsum with the humeri, lateral edges to the base of the wings, and the posterior angles yellow.....	23 <i>arsalis</i>
14.	Dorsum black with the humeri, lateral edges, and two stripes extending forward on each side of the flattened space yellow.....	6 <i>tridens</i>
	Dorsum of the thorax gray.....	15
15.	Dorsum of the thorax with three metallic brown vittæ.....	31 <i>albospinosa</i>
	Dorsum with two nonmetallic brown vittæ.....	22 <i>bivittata</i>

- |     |  |   |
|-----|--|---|
| 16. | Dorsum of the thorax with the flattened space before the scutellum black,<br>gray, green, or blue..... | 17  |
|     | Dorsum with the flattened space yellow.....  | 25  |
| 17. | Flattened space on the dorsum a beautiful greenish blue.....   | 7 <i>signifer</i>                         |
|     | Flattened space black, gray, or dull green.....  | 18  |
| 18. | Flattened space on the dorsum and more or less of the dorsum dull green.                               |   |
|     | Flattened space black or gray.....   | 19 <i>tenuis</i>                          |
|     | Flattened space and most of the dorsum gray.....   | 22 <i>bivittata</i>                       |
|     | Flattened space black.....   | 20  |
| 20. | Dorsum of the thorax and the black central line shining.....   | 5 <i>nitida</i>                           |
|     | Dorsum less shining, and without distinct central line.....  | 21  |
| 21. | Dorsum with the anterior half and three stripes extending backward<br>black.....                       | 6 <i>tridens</i>                          |
|     | Dorsum with only the flattened space black.....  | 22  |
| 22. | Front metatarsi only three-fourths as long as their tibiæ.....   | 4 <i>carbonifer</i>                       |
|     | Front metatarsi about equal to their tibiæ.....  | 23  |
| 23. | First and second joints of hind tarsi equal.....   | 3 <i>dimidiata</i>                        |
|     | Second joint of hind tarsi longer than the first.....  | 24  |
| 24. | Posterior cross-vein rectangular.....  | 1 <i>rubella</i>                          |
|     | Posterior cross-vein a little oblique.....   | 2 <i>perplexa</i>                         |
| 25. | Abdomen fasciate with black.....   | 26  |
|     | Abdomen not distinctly fasciate.....   | 27  |
| 26. | Dorsum of the thorax without black spots. Length 3 mm.....   | 12 <i>aldrichii</i>                       |
|     | Dorsum with three black spots. Length 4.5-5 mm.....  | 8 <i>maculata</i>                         |
| 27. | Dorsum of the thorax dull with thick yellow pollen.....  | 28  |
|     | Dorsum shining, only thinly pollenose, pollen whitish.....   | 29  |
| 28. | Dorsum evenly and thickly pollenose.....   | 11 <i>flava</i>                           |
|     | Dorsum with pollenose vittæ.....   | 18 <i>transversa</i>                      |
| 29. | Tips of third and fourth veins widely separated.....   | 14 <i>disjuncta</i>                       |
|     | Tips of third and fourth veins approximated.....   | 30  |
| 30. | Veins yellow.....  | 9 <i>floridula</i>                        |
|     | Veins brownish.....  | 10 <i>floridula</i> var. <i>infuscata</i> |

### 1 *Neurigona rubella* Loew.

#### Figure 1.

*Saucropus rubella* Loew, Neue Beitr., viii, p. 76, 1861; Mon. N. Am. Diptera, ii, p. 226, 1864.

Thorax and abdomen yellow, the former with the flattened space before the scutellum black, the latter with black bands; hypopygium black; front metatarsi about one and one fourth times as long as their tibiæ, with bristles below. Length 5 mm.

Male: Face very narrow, almost linear, and with the palpi silvery white; proboscis yellow; antennæ deep yellow, the first joint paler, arista yellowish brown; front and occiput black, the ground color concealed by thick white pollen. Dorsum of the thorax reddish yellow with the flattened space before the scutellum black and covered with whitish pollen; humeri and pleuræ pale yellow, the latter with white pollen, and with a black spot in front of the halteres; metanotum black, with the sides yellowish. Abdomen yellow, dorsum of the second, third, and fourth segments with black bands, that on the second near the base and narrowing at the extreme lateral edges, that on the third at the base and of equal width throughout, the one on the fourth at base and narrowed at the sides not reaching the lateral edges, but forming a subtriangular spot; fifth segment straight above with the front and hind angles square, the upper edge infuscated, and with the

ventral sheath black; the hairs on the dorsum of the abdomen appear reddish or yellowish when viewed from above, but more blackish when seen from the side; hypopygium small, testaceous, rounded above, with yellow hairs on the upper part, appendages partly yellowish. Legs yellowish; front coxæ with delicate yellow hairs on the front surface and yellow bristles near the tip, these bristles brownish in certain lights; middle coxæ with black hairs and bristles on the front side near the tip, and some very minute yellow hairs above; hind coxæ with the usual black bristles on the outside, there is also a small bristle on each middle and hind trochanter; front metatarsi one and one-fourth times as long as their tibiæ, the remaining four tarsal joints taken together somewhat shorter than their tibiæ, second and third joints brownish; front tibiæ and tarsi with the hairs long, and with a row of longer hair-like bristles on the lower surface of the tibiæ and the first three joints of the tarsi, these hairs nearly as long as the diameter of the tarsal joints, there is also a row of shorter and stouter hairs on the upper surface of these joints; middle metatarsi about as long as their tibiæ, the remaining four joints together about one-fifth shorter than their tibiæ; hind tarsi about as long as their tibiæ, second joint a little longer than the first; middle and hind tarsi brown from the tip of the first joint. Wings hyaline, tinged with yellowish in front of the third vein; posterior cross-vein perpendicular to the fifth vein; third vein bent backward at tip, fourth vein quite sharply arched forward from a little beyond the middle of its last section and ending rather close to the tip of the third vein; tip of the fourth vein distinctly before the apex of the wing; posterior cross-vein about twice its length from the wing margin measured on the fifth vein; veins brownish.

Female: Differs from the male in having the bristles of the front coxæ black, these bristles are large and conspicuous; the front tarsi are brownish and hardly twice as long as their tibiæ, the first joint hardly as long as their tibiæ; middle metatarsi a little shorter than their tibiæ; second joint of hind tarsi only slightly longer than the first.

Dr. Loew says in his description of this species that the metanotum is black only on its base and along the center. I have specimens before me which exactly agree with this, but others have the metanotum almost entirely black, only a very little yellowish at the sides.

I have described the male of this species from two specimens: one in the National Museum collection, taken by Mr. Burgess at Beverly, Mass., September 6, 1874, and the other (a broken specimen) taken at Sea Cliff, N. Y., by Mr. Nathan Banks. The males seem to be rare, although the females are taken all through the eastern states quite commonly; I have taken them around Buffalo, N. Y., and have seen specimens from Connecticut, Massachusetts, New Jersey, Pennsylvania, Virginia, and Kansas. Mrs. Slosson reports it from New Hampshire.



Note.—The females of the five following species which have the dorsum of the thorax yellow, and the flattened space before the scutellum black can be separated as follows: *nitida* differs from the other four by having a central shining black line on the dorsum; *carbonifer* has the front metatarsi only three-fourths as long as their tibiæ, while in *dimidiata*, *rubella*, and *perplexa*, the front metatarsi are nearly equal to their tibiæ; in *dimidiata* it is fully as long, and in the others hardly as long as their tibiæ, *dimidiata* has the first and second joints of the hind tarsi equal, while in the other two the second joint is distinctly the longest, in the last two the bend in the last section of the fourth vein is sharper, and the tarsi are darker than in *dimidiata*; the only difference between the females of *rubella* and *perplexa* that I can see is that in *rubella* the posterior cross-vein is rectangular while in *perplexa* it is a little oblique, but it is difficult to separate them.

I have compared the female of the European species *N. quadrifasciata* Fab. which is the type species of the genus, and closely related to this group, and find that it differs from all of our five species mentioned above, by having the third and fourth veins more widely separated at the tips, the fourth vein ending in the apex of the wing, while in our species the fourth vein ends distinctly before the apex of the wing. Fig. 28 is the apical part of the wing of *quadrifasciata* Fab.

I have also examined *N. suturalis* Fall. of Europe, and find it quite distinct from any of our species.

## 2 *Neurigona perplexa* n. sp.

Figure 2.

Thorax and abdomen yellow, the former with the flattened space before the scutellum black, and the latter with black bands; hypopygium black, small. Hairs and bristles of the front coxæ whitish; front metatarsi about the length of their tibiæ. Length  $4\frac{1}{2}$  mm.

Male: Face very narrow, eyes almost touching on the center of the face, leaving only a small triangle above and below, face and palpi silvery white; proboscis and antennæ yellow, arista brownish; front and occiput black, covered with white pollen; frontal and post-vertical bristles black; orbital cilia whitish. Thorax yellow; the humeri and lateral edges of the dorsum whitish yellow; flattened space before the scutellum black, with white pollen; a dark central line on the dorsum between the acrostichal bristles, reaching from the black flattened space to the front of the dorsum (this may not be found in all specimens); pleuræ pale yellow, with white pollen, and the usual black spot in front of the halteres; scutellum yellow with a black spot at base; bristles of

the thorax black, those on the posterior part large, a space on each side above the humeri and reaching about half way to the root of the wings covered with short black bristles; metanotum black with yellow on the sides. Abdomen yellow with black bands at the base of the second, third, and fourth segments, these bands narrowed laterally, hardly reaching the sides below, and emarginate on the center of the dorsum; fifth segment small, with the ventral sheath black; hairs of the abdomen black, those on the fifth segment, and a few along the sides yellow; hypopygium black or testaceous, small, subquadrate, and rounded behind. Legs pale yellow; front coxæ with yellow hairs and bristles; middle coxæ with black hairs and bristles; front metatarsi about the length of their tibiæ, the four remaining joints together about the length of the first, the fourth joint very slightly flattened, third joint nearly twice the length of the fourth; hairs on the front tarsi quite long; middle metatarsi about as long as their tibiæ; hind tarsi with the second joint longer than the first. Wings hyaline, hardly tinged with grayish; veins yellowish brown; posterior cross-vein somewhat oblique.

Female; I place with the male described above a single female closely related to *rubella*, but somewhat smaller and with the posterior cross-vein a little oblique; it agrees with the male in all but sexual characters.

Described from one male in the National Museum collection, taken at Lehigh Gap, Pa., July 23, 1907, by C. T. Greene; and one female sent me by Prof. C. W. Johnson and labeled *Capens*, Me., July 21, 1901.

Note.—This is closely related to *rubella* and *nitida*, but the male differs from the later by having only a black central line on the dorsum of the thorax, the abdominal bands are emarginate, the front tarsi have shorter hairs below, the fourth joint is very slightly flattened, and the posterior cross-vein is twice its length from the wing margin measured on the fifth vein, in *nitida* it is less than twice its length from the margin and the fourth joint of front tarsi is cylindrical. From *rubella* it differs in having the front of the wing less arched; all the tarsi are darkened from the base a little, but the dark part not as distinctly marked as in *rubella*, the front metatarsi are about the same length as their tibiæ while in *rubella* they are very distinctly longer. In *rubella* the third and fourth joints of the front tarsi are about equal while in this species the third is nearly twice as long as the fourth. This species is a little smaller than *rubella* and the posterior cross-vein is a little oblique while in *rubella* it is perpendicular to the fifth vein. It differs from *dimidiata* by having black hairs and bristles on the middle coxæ, while *dimidiata* has only yellowish hairs and

bristles on the middle coxæ; *dimidiata* also has pale hairs on most of the first four segments of the abdomen while in this species they are mostly black, the front of the wing in this species is also more arched.

### 3 *Neurigona dimidiata* Loew.

Figure 3.

*Saucropus dimidiata* Loew, Neue Beitr., viii, p. 75, 1861; Mon. N. A. Diptera, ii, p. 225, 1864.

Thorax and abdomen yellow, the former with the flattened space and sometimes a central line black, the latter with black bands; bristles and hairs of the front and middle coxæ all yellowish; front metatarsi about the same length as their tibiæ. Length 4 mm.

Male: Eyes almost touching on the middle of the face; face and palpi silvery white; proboscis and antennæ yellow, arista brownish; front and occiput black, thickly white pollenose, the pollen on the occiput, the flattened space before the scutellum, and the metanotum appears to be tinged with blue; orbital cilia whitish. Thorax yellow, reddish yellow and shining on the dorsum, white pollenose on the pleuræ, there is the usual small black spot on the pleuræ in front of the halteres; the flattened space on the dorsum black, and a black central line extends from this to the front of the thorax between the acrostichal bristles, this line seems to be a variable character, in one of the specimens before me it is almost wanting; humeri yellowish white; metanotum black; scutellum yellow, lighter colored on the disk and somewhat shining. Abdomen yellow with rather narrow black bands on the second, third, and fourth segments, those on the third and fourth sometimes not very sharply defined; the hairs of the abdomen mostly yellowish, the marginal row of bristles on the first segment black and rather short; fourth segment produced on the venter on the posterior end; fifth segment higher than long, somewhat pointed in front on the dorsum, entirely yellow except the brown ventral sheath, and with rather long yellow hair. Hypopygium black or testaceous, polished, and rather small with yellowish appendages. Legs pale yellow; front and middle coxæ with all the hairs and bristles yellowish white; hind trochanters with a small black bristle; front tarsi more than twice the length of their tibiæ, and with a row of long hairs below; front metatarsi a little longer than their tibiæ; middle metatarsi about the same length as their tibiæ; hind tarsi a little shorter than their tibiæ, first joint a very little shorter than the second; all the tarsi infuscated from the tip of the first joint. Wings hyaline, very slightly tinged with grayish; the bend in the fourth vein rather sharp and at the middle of the last section; tip of the fourth vein before the apex of the wing; posterior cross-vein a little less than twice its length from the wing margin, measured on the fifth vein.

Female: A single female that I take to be the female of this species has black hairs and bristles on the middle coxæ, and black bristles and yellow hairs on the front coxæ; the front tarsi twice as long as their tibiæ, the metatarsi being as long as the tibiæ; middle metatarsi as long as their tibiæ; first and second joints of hind tarsi equal.

This seems to be a southern species, Dr. Loew reporting it from Florida and Washington, D. C.; the only specimens I have seen (one female and two males) were taken by Mr. Nathan Banks at Falls Church, Va., July 10th to Sept. 26th.

#### 4 *Neurigona carbonifer* Loew.

Figure 4.

*Saucropus carbonifer* Loew, Diptera Americae Septentrionalis Indigena, ix, 84, 1869.

Thorax and abdomen yellow, the former with the flattened space in front of the scutellum black, the latter with black bands; hypopygium yellow; front tarsi with an oval tip. Length 4-5 mm.

Male: Face and palpi silvery white, the latter longer and narrower than in most species; face rather wide for a male, and with the sides nearly parallel; front and occiput black, thickly covered with white pollen; proboscis and antennæ yellow, the latter with the third joint small, arista brownish; orbital cilia and post-vertical bristles yellowish. Thorax reddish yellow, flattened space before the scutellum, a large spot on the pleuræ, another above and in front of the middle coxæ, and a small spot in front of the halteres black; a dark line between the acrostichal bristles, and sometimes along the row of bristles on either side; humeri yellowish white; bristles of the dorsum well developed, a large yellow bristle on the pleuræ above the front coxæ; scutellum pale yellow, slightly darkened at base; metanotum black. Abdomen yellow more or less distinctly banded with black on the second and third segments; first and fifth segments with yellowish hairs, the large bristles on the hind margin of the first, and the hairs on the dorsum of the second, third, and fourth segments black; venter yellow with long, yellow hairs on the fourth segment, hypopygium, its appendages, and the sheath on the venter of the fifth segment yellow. Coxæ and legs pale yellow, all the hairs and bristles of the front coxæ whitish, sometimes the larger bristles brownish in certain lights; middle coxæ with a few black hairs and bristles in front near the tip; front tarsi twice as long as their tibiæ first joint three-fourths as long as their tibiæ, the fourth joint whitish and widened at the tip, fifth joint black, flattened, forming an oval tip to the tarsi; middle metatarsi about the same length as their tibiæ; first joint of hind tarsi shorter than second, wings hyaline; veins brown; last section of fourth vein very sharply bent forward near the middle, ending before the apex of the wing, rather close to the tip of third vein.

Female: Venation the same as in the male; front metatarsi about three-fourths as long as their tibiæ; front coxæ with yellow hairs and black bristles; the bands on the abdomen narrow but sharply defined; there are no black spots on the pleuræ as in the male except the usual one in front of the halteres; and no central line on the dorsum; the flattened space before the scutellum seems to be black as in the male, but is so much injured by the pin that I cannot be sure.

Redescribed from eight males and one female, three of the males are from Prof. Aldrich's collection, two were taken at Battle Creek, Mich., and one at National Park, N. J.; this last was taken by Mr. V. A. E. Daecke; two males were in Mr. Nathan Banks' material, and were taken by him at Glencarlyn, Va.; and three were sent me by Prof. C. W. Johnson, and are from Buttonwoods, R. I., Hanover, N. H., and Cohasset, Mass.; the female is in the American Entomological Society's collection and was taken at Manayunk, Pa. The one from New Jersey was taken May 20th, the others were taken in June and July.

Note.—I have placed this single specimen as the female of this species as it agrees in all the principal characters with the male.

5 *Neurigona nitida* n. sp.

Figure 5.

Thorax and abdomen yellow, the former shining black on the dorsum, the latter with three wide black bands. Hypopygium black, hairs and bristles of the front coxæ whitish. Length,  $4\frac{1}{2}$  mm.

Male: Face very narrow, white; palpi white; proboscis yellow; antennæ yellow, arista brownish. Front and occiput black with white pollen; frontal and post-vertical bristles black; orbital cilia white. Mesonotum reddish-yellow along the lateral margins, black on most of the disk and very shining, with a greenish reflection. Pleuræ yellow with white pollen, humeri more whitish; flattened space before the scutellum with gray pollen, scutellum yellow with a black base. The pleuræ with a black spot in front of the halteres, and another above the hind coxæ. Metanotum black, abdomen yellow with wide black bands on the dorsum of segments two, three and four, that on the second near the base and narrowed laterally, those at the base of the other two about equal width throughout; fifth dorsal segment produced anteriorly in a blunt, blackish point; the usual bilobed sheath on the venter black; hairs of the first four segments black, those of the fifth pale. Hypopygium not very large, shining black, basal part subquadrate, appendages pale yellow. Front coxæ with white hairs and bristles, middle ones with black hairs; front metatarsi as long as their tibiæ, with a row of long bristles on the bottom, continued on the next three joints; those on the metatarsi a little longer than the diameter of that joint; second and third joints fuscous, fourth and fifth a little lighter; middle metatarsi nearly as long as their tibiæ; hind tarsi with the second joint longer than the first; middle and hind tarsi infuscated from the base. Wings hyaline, tinged with brownish, darker on the front; fourth vein bent forward, ending not far from the tip of the third vein, and some distance front of the apex of the wing.

Female: Differs from the male in having only the central line between the acrostichal bristles and the flattened space before the scu-

tellum black, the central line is narrowed to a point anteriorly, hardly reaching the front of the mesonotum, the flattened space is thickly covered with white pollen; the front coxæ have pale hairs and black bristles; the front tarsi a little infuscated on the last four joints, middle ones fuscous from the tip of the first joint; abdomen with even black bands on the tergum of segments two to five.

Described from two males and one female in the collection of Prof. J. M., Aldrich taken in Polk Co., Wis., in July, by Mr. Baker; and one female in the National Museum collection taken at Franconia, N. H., by Mrs. Slosson.

#### 6 *Neurigona tridens* n. sp.

Figure 6.

Thorax dark reddish yellow, with a large three pronged black mark on the dorsum; abdomen yellow with black bands. Length 3 1-3 mm.

Female: Face silvery white; antennæ yellow; arista yellowish brown; front and occiput black with white pollen; orbital cilia white. Dorsum of the thorax dark reddish yellow on the lateral and posterior edges, and the humeri; central portion largely black, the black extending to the front of the mesonotum, and on the posterior part forming three vittæ, the central one ending in the flattened space before the scutellum, this space being also black, and the lateral vittæ not quite reaching the scutellum; pleuræ partly black, dorsum somewhat shining, thinly pollenose, the pollen thicker on the flattened space; scutellum yellow; metanotum black, abdomen yellow with broad black bands at the base of the second to fifth segments, these bands occupy more than half of the segments on the center of the tergum, but narrow laterally; venter yellow; hairs and bristles of the abdomen black. Legs pale yellow; hairs and bristles of the front coxæ black; front metatarsi four-fifths as long as their tibiæ, the remaining four joints taken together but little longer than the first; front tarsi blackened from the tip of the first joint; hind tarsi shorter than their tibiæ, the second joint longer than the first, last four joints black, contrasting sharply with the pale yellow of the first joint, but the extreme tip of the first joint brown. Wings brownish hyaline; veins dark brown; fourth vein ends in the apex of the wing rather close to the tip of the third vein.

Described from one female in the collection of Prof. J. M. Aldrich, and taken on Mt. Constitution, Orcas, Idaho, July 7, 1905.

#### 7 *Neurigona signifer* Aldrich.

*Neurigona signifer* Ald. Transactions of the Entomological Society of London, 1896, pt. 3, p. 337.

The following is a copy of the original description, as I have not seen this species.

"Male: Face very narrow, immediately under the antennæ is a triangular portion of yellow, below this there is only a narrow groove between the eyes to below the middle, from this point the face pro-

trudes as a narrow whitish wedge, slightly wider at the bottom; proboscis brownish; palpi yellow; front greenish-brown, a little dusted, converging below; antennæ yellow, third joint with a short point, arista yellow; inferior orbital cilia whitish; occiput green with white dust. Thorax dark yellow glabrous, with black bristles, acrostichal bristles small, in two rows, on each side of these in front is an area of small bristles, bounded by the humeri and the anterior margin. The flat baræ disk is a beautiful greenish-blue color, which extends to the disk of the scutellum, sides and border of the scutellum yellow; two very large bristles between two very minute ones on the border; a very large bristle behind the root of the wing; pleuræ deep yellow, imperceptably dusted, a dark spot above middle coxæ; tegulæ cilia whitish. Abdomen slender, yellow, the segments beyond the second successively shorter, the second segment bears near its front margin an opaque black band, emarginate behind in the middle, and rounded at each end. It is about half as wide as the segment. The following segments have similar bands, less emarginate, and occupying more of the width of the segments, the fifth is wholly black across the dorsum. Like the others it is yellow along the ventral sides; hypopygium shining black, turned under, club-shaped, not much exerted, the appendages not distinct. All the coxæ yellow, front ones long with black hairs and mixed brownish-yellow bristles, middle ones with black hairs, hind ones with a single bristle on the outside; legs yellow, simple, the bristles small, tarsi a little infuscated towards the tip. Wings a little yellowish, fourth vein in its last segment only very gently curved, almost perfectly parallel with the third.

Female: Face narrow, strongly protruding below, yellow, and yellow pollenose, palpi larger than in the male; third joint of the antennæ small, exceedingly short, almost kidney shaped.

Length  $3\frac{1}{2}$  mm., wing  $3\frac{4}{10}$  mm.

St. Vincent, 1500 feet altitude. Occurs also in Grenada."

Note.—*N. brasiliensis* Schin. is closely related to this species agreeing with it in coloration; it was described from a female, but it can be distinguished from *signifer* Ald. by its having a central line on the dorsum, extending from the flattened space before the scutellum about half way to the front of the thorax, this line is the same color as the flattened space; and by having the third and fourth veins much more convergent than in *signifer*.

I have seen two specimens which I refer to *brasiliensis*, one a male in the National Museum, and the other a female in the collection of Prof. J. M. Aldrich; the former is from Grenada, and the later from Vera Cruz.

8 *Neurigona maculata* n. sp.

Figure 8.

Mesonotum reddish yellow, with three black vittæ or spots; pleuræ with black spots; abdomen yellow with black bands; middle metatarsi with a row of long bent bristles below; hypopygium small, shining black. Length 4-5 mm.

Male: Face and palpi white; eyes narrowly separated at the center of the face; proboscis and antennæ yellow, arista brownish; front and occiput black, thickly covered with white pollen; orbital cilia whitish, post-vertical bristles yellowish. Mesonotum reddish-yellow with three black vittæ or spots, the central one subquadrate (in one of my specimens this spot is missing), lateral spots oval and quite variable in size; humeri yellowish white; pleuræ pale yellow with white pollen, and with a large black spot in the center, a long spot between the front and middle coxæ sometimes connected with the central spot, a small spot above the hind coxæ, and the usual small spot in front of the halteres; scutellum yellow with the extreme base black; metanotum black, a little shining, and white pollenose. Abdomen yellow with three wide black bands, one near the base of the second segment, and one at the base of the third and fourth segments, these bands widest on the center of the dorsum; fifth segment with a narrow black dorsal line and sometimes a very narrow basal band; venter yellow; fifth segment without a ventral sheath. Hypopygium and its appendages shining black, polished, rather small, and with a few scattering pale hairs. Legs pale yellow; front coxæ with delicate yellowish hairs in front, and black bristles near the tip; front metatarsi about as long as their tibiæ, the fourth joint short, about as broad as long; middle metatarsi nearly as long as their tibiæ, and with a row of long bristles on the lower side, these bristles more or less bent backwards at tips; this row of bristles continued on the tibiæ but the bristles scattering and straight; hind tarsi with the first and second joints equal. Wings grayish hyaline, a little darker in front; last section of fourth vein bent forward a little from a little beyond the center, not very close to third at tip; tip of fourth vein a little before the apex of the wing.

Female: Agrees with the male in all but sexual characters, except that it has only short scattering bristles on the lower side of the middle metatarsi; and the fourth joint of the front tarsi are longer than in the male; in one specimen the lateral spots on the dorsum of the thorax are wanting.

Described from five males and ten females from Canada, N. H., Mass., N. Y., Pa., N. C., Mich., and Wis. I have taken them in the vicinity of Buffalo, N. Y., and at Toronto, and Kearney, Ont., from June 10 to July 9; Prof. J. M. Aldrich sent me specimens from Polk Co., Wis., taken in July, from Philadelphia, Pa., taken by Mr. V. A. E. Daecke, June 12, and from Battle Creek, Mich.; Mr. Nathan Banks sent specimens



from Sea Cliff, and Ithaca, N. Y.; Prof. C. W. Johnson sent specimens from Chester, Mass., taken August 4; Brookline, Mass., June 18; Hampton, N. H., July 10, taken by S. A. Shaw, and from Lake Toxaway, N. C., taken by Mrs. Slosson; the National Museum collection has a specimen taken at Mt. Washington, N. H., by Mrs. Slosson.

### 9 *Neurigona floridula* Wheeler.

Figure 9.

*Neurigona floridula* Wheeler, Proc. Cal. Acad. Sci. ii, p. 72, 1899.

Thorax and abdomen yellow; hypopygium with the first half yellow, last half black; front tarsi plain, with the fourth joint of front tarsi less than one-half as long as third; wings tinged with yellow. Length 5 mm.

Male: Face rather wide for a male, white; palpi white; proboscis yellow; front and occiput black, thickly covered with white pollen, thinner on the center of the front; antennæ yellow, third joint a little infuscated, arista brown; frontal bristles black, orbital cilia and post-vertical bristles whitish yellow. Mesonotum yellow, shining; pleurae paler, opaque and with a coat of white pollen, with a black line in front of the halteres; metanotum and scutellum yellow, a little shining; outer hairs of the scutellum small but distinct. Abdomen yellow, darker on the third and fourth segments; third with a narrow dark band near the posterior end, continued across the venter (sometimes this band is indistinct); dorsum of the fourth segment with a poorly defined wide blackish band; fifth light yellow; venter yellow with a transverse row of long yellow hairs on the third segment; hairs on the second, third and fourth segments mostly black, those on the first and fifth yellow, the marginal row of bristles on the first segment black; hypopygium a short oval in outline, compressed laterally, the basal part yellow, last part black or testaceous, the yellow part nearly two-thirds of the whole. Legs light yellow; front coxæ with short yellow hairs on the whole of the front and with black bristles near the tip; middle coxæ with black hairs and bristles; front and middle metatarsi about the same length as their tibiæ; fourth joint of front tarsi less than one-half as long as third; second joint of hind tarsi distinctly longer than first; tegulae, their cilia, and the halteres light yellow. Wings hyaline, strongly tinged with yellow in front of fourth vein, third and fourth veins convergent, fourth vein ending in apex of the wing, not very close to the tip of third; veins yellowish; anal angle obsolete.

The following is a copy of Prof. Wheelers description of the female. I give it in full for the benefit of those who may wish to study the synonymy of this species.

"Female: Length  $4\frac{1}{2}$ - $5\frac{1}{2}$  mm., length of wing  $4\frac{3}{4}$ -5 mm. Proboscis reddish yellow with pale hairs; palpi and face yellow, thickly covered with silvery white dust, the latter of the usual width for a female, and with the portion below the transverse suture receding; antennæ yellow,

third joint lacking; (I find it small and the arista brown) front and occiput black, thickly covered with silvery white dust; post-ocular cilia white; eyes green. Thorax, scutellum, and abdomen reddish yellow, covered with white dust, which is most abundant on the lateral portions of the thoracic dorsum and the pleuræ; prescutellar depression shallow; scutellum with two median long bristles and two feeble lateral bristles. Abdomen covered with short black hairs; pleuræ with a black spot below the root of the wing. Coxæ reddish yellow dusted like the pleuræ; anterior surface of the fore coxæ beset with short white hairs, and a few conspicuous black bristles near their proximal ends; similar bristles occur in a corresponding position in the middle coxæ; hind coxæ with a single bristle on the lateral surface, and a few bristles near the tip. Legs and metathoracic epimera light yellow; the femora very slender and covered with small black hairs; last joint of all the tarsi black; fore tarsi twice as long as the fore tibiæ; middle tarsi nearly twice as long as the middle tibiæ; hind tarsi scarcely as long as the hind tibiæ, hind metatarsi distinctly shorter than the succeeding joint. Wings scarcely narrowed towards the base, distinctly yellowish, and with yellow veins; apical segment of fourth vein rather sharply bent upwards near its middle, ending rather close to the tip of the third vein; posterior cross-vein about two and one-half times its length from the posterior margin of the wing, measured along the distal segment of the fifth vein. Halteres and tegulæ yellow, the latter with yellow cilia."

In the above description Prof. Wheeler states that the wings are scarcely narrowed towards the base. I find in all the species that I have seen that where the wings of the male are narrowed at base so as to leave little or no anal angle that the wings of the females are normal, and have the anal angle prominent, as is the case with this species. Male described from three specimens, one in the collection of Prof. Aldrich, taken by Mr. Daecke, at Philadelphia, Pa.; one received from Mr. Daecke and taken by him at Perdix, Pa., on June 10; the other in the National Museum collection, and taken on Mt. Washington, N. H., by Mrs. Slosson. I have seen females from the following states: Me., N. H., Vt., N. J., N. Y., Pa., Md., Del., Va., N. C., Ohio, Mich., and Canada. Prof. Wheeler also mentions Illinois.

Note.—In Prof. Aldrich's Catalogue of North American Diptera, *floridula* is placed as the female of *carbonifer*, but after careful study of the material in my hands I prefer to place *floridula* as a distinct species, and place the male described above with it, as they agree in all essential characters, except those points which usually form the sexual distinction.

10 *Neurigona floridula* var. *infuscata* n. var.

Figure 10.

Thorax and abdomen yellow, the latter with more or less distinct bands; hypopygium black, more or less yellow on the first half; front tarsi plain, and with the fourth joint more than one-half as long as the third; tip of the wing infuscated. Length,  $5\frac{1}{2}$  mm.

Male: Face rather wide for a male, somewhat narrowed in the middle, silvery white; antennæ yellow; front and occiput black, covered with white pollen; orbital cilia and post-vertical bristles yellowish white. Thorax yellow, shining on the dorsum; flattened space before the scutellum dull with yellowish pollen; pleuræ paler and covered with white pollen, a black line in front of the halteres, also a black spot in front of the middle coxæ; metanotum yellow, more or less infuscated close to the abdomen; scutellum yellow, paler below. Abdomen yellow, the first segment paler and more or less infuscated at base; second and sometimes the third segment with a distinct black band at base; fourth segment more or less infuscated, but hardly banded; sometimes the third and fourth segments almost entirely yellow; venter yellow, with a transverse black line at hind margin of third segment, this line fringed with long yellowish hairs; hairs on the dorsum of the second, third, and fourth segments black, except on the lower edges where they are more yellowish. Hypopygium black, shining, and testaceous or yellowish on the first half. Legs pale yellow; front coxæ with yellow hairs on the front side, and black bristles near the tip; hairs and bristles of the middle coxæ black; a black bristle on each middle and hind trochanter; a few yellowish hair-like bristles at base of middle femora below; one or two yellowish bristles above front coxæ; front tarsi hardly twice as long as their tibiæ, the first joint about the same length as the remaining four joints together; fourth joint less than one-half as long as the third; fifth joint black; middle metatarsi the same length as their tibiæ; first joint of hind tarsi shorter than the second; middle and hind tarsi infuscated almost from the base. Wings hyaline, strongly tinged with brown along the front, and with a distinct cloud at tip; last section of fourth vein bent forward at the middle and ending in the apex of the wing, not far from the tip of the third vein; anal angle obsolete; veins yellowish brown to brown.

Female: Differs from the male in the form of the wings, the anal angle being well developed; wings a little less tinged with brown in front, and without the cloud at tip. Abdomen without distinct bands, but sometimes darkened in spots.

Described from thirteen males, which I took at Little Valley, N. Y., June 10, 1912; and twenty females from Pa., R. I., Mass., N. Y., N. J., Mich., and Wis.

This may be a distinct species, but I cannot find any structural character to separate it from *floridula*. Both sexes are a little larger and more robust than the specimens of *floridula*

that I have seen; the male has the tip of the wing infuscated, the hypopygium is darker in color, the pleuræ have a black spot above the middle coxæ, and the wing veins are darker. The female is difficult to separate from *floridula*, but they are a little more robust, and darker in color.

#### 11 *Neurigona flava* n. sp.

Figure 11.

Yellow, with yellow pollen. Abdomen with lateral brown spots. Wings tinged with yellow. Length  $4\frac{1}{4}$  mm.

Female: Face and palpi white; antennæ yellow, the first joint paler, arista brown; front and occiput black, thickly covered with yellowish-white pollen; frontal bristles black, orbital cilia and post-vertical bristles yellowish. Dorsum, scutellum, and metanotum yellow, evenly yellow pollinose, humeri and pleuræ whitish-yellow, and yellowish pollenose, a black line in front of the halteres. Abdomen yellow, with narrow brown lateral spots on segments three and four; these spots are at the base of the segments and scarcely form bands; hairs of the abdomen mostly black. Legs pale yellow, tarsi scarcely darkened at tip, fore coxæ with yellow hairs and black bristles; second joint of hind tarsi longer than first; front and middle metatarsi three-fourths as long as their tibiæ. Wings strongly tinged with yellow, all veins bright yellow; fourth vein ends in tip of the wing, a considerable distance from the tip of the third vein.

Described from one female in Prof. J. M. Aldrich's collection, and taken at Lewiston, Idaho, on June 17, 1902.

Note.—This species may be distinguished from *transversa* by the deeper yellow pollen of the dorsum being evenly distributed; in this species the acrostichal bristles are very poorly developed, while in *transversa* they are very conspicuous. In this, the second joint of the hind tarsi are distinctly longer than the first, the wings have a strong yellow tinge and the veins are bright yellow, all of which is different in *transversa*.

From *floridula* it differs by the dense yellow pollen of the dorsum, and the third and fourth veins being much further apart, the wings are also a brighter yellow, but this character is of little use unless the student has both species before him.

#### 12 *Neurigona aldrichii*, n. sp.

Figure 12.

Thorax and abdomen yellow, the latter with black bands; hypopygium black and yellow; second joint of front tarsi shorter than the fourth, flattened, and widened at tip. Length  $3-3\frac{1}{2}$  mm.

Male: Face and palpi white; eyes contiguous; antennæ and proboscis yellow, arista brownish yellow; front and occiput dark grayish green with white pollen; orbital cilia whitish. Thorax yellow, shining;

humeri, pleuræ, scutellum, and the flattened space before paler; scutellum with a blackish spot at base; pleuræ with a black line in front of the halteres, this line sometimes broken into two spots; metanotum black. Abdomen yellow with narrow black bands near the base of segments two, three, and four, the first sometimes infuscated at base; hairs of the abdomen mostly pale; hypopygium nearly as long as segments four and five, but not very thick, first half yellow, last half black or testaceous. Legs pale yellow; front coxæ with a few yellow bristles near the tip; middle coxæ with black hairs and bristles; front metatarsi hardly as long as their tibiæ, second joint shorter than fourth, and with the apex widened and extended in the form of a short spur on top, somewhat infuscated at tip; third joint a little longer than fourth, and both with a row of short bristles below, these bristles hardly as long as the diameter of the joint; middle metatarsi about four-fifths as long as their tibiæ, fourth joint slightly flattened, fourth and fifth joints fuscous; apical half of middle tibiæ brown; hind tarsi with the first joint a little shorter than the second, and becoming fuscous from the tip of the first joint. Wings grayish hyaline; fourth vein bent forward from the center of the last section, the tip quite close to the tip of the third vein, and some distance in front of the apex of the wing.

Female: Differs from the male in having the face quite wide; the abdomen with the hind margins of segments two and three, and sometimes the bases of all the segments infuscated; the hairs and bristles of the front coxæ black; all the tarsi normal and scarcely infuscated; metanotum yellow.

Described from two males and five females, taken by Prof. J. M. Aldrich, at Lawrence, Kansas, on June 8th.

### 13 *Neurigona transversa* n. sp.

Figure 13.

Thorax reddish yellow, with three pollenose vittæ; abdomen yellow, with the hind margins of the segments pale; a narrow black line above the pronotum. Length 5-5½ mm.

Female: Face wide, with the sides parallel; face and palpi whitish; antennæ deep yellow, first joint paler; palpi with yellow bristles at tip; front and occiput black, thickly whitish pollenose; frontal bristles brownish yellow, orbital cilia rather long and whitish. Dorsum of the thorax reddish yellow, with three vittæ formed with yellowish pollen, the narrow central one between the acrostichal bristles has the pollen more dense, the lateral vittæ not so sharply defined. There is a bare spot above the root of the wing in each of these vittæ; metanotum, scutellum, and the flattened space in front thickly covered with yellowish pollen, which is thinner at the base of the scutellum, the pollen on the lower part of the pleuræ more whitish; the usual black line in front of the halteres; a yellow bristle above the front coxæ; front of the mesonotum with a black transverse line which is almost interrupted in the middle. Abdomen reddish yellow, slightly infuscated, and with distinct yellowish white bands on the hind margins of the segments, that

on the fifth not as distinct as on the other segments, and that on the first widest; halteres, tegulæ, and their long cilia yellowish white. Hairs and bristles of the coxæ black, except the short hairs on the front coxæ which are yellow and easily overlooked; the front and middle metatarsi about three-fourths as long as their tibiæ; tips of the tarsi infuscated; first and second joints of the hind tarsi equal. Wings grayish hyaline; fourth vein ends in the apex of the wing, the tip widely separated from the tip of the third vein; veins brown.

Described from two females taken at Moro Lake, Cal., July 23, 1911, by Prof. J. M. Aldrich.

#### 14 *Neurigona disjuncta* n. sp.

Figure 14.

Thorax and abdomen yellow, the latter sometimes with black bands; hypopygium yellow, appendages testaceous; front tarsi plane, with the fourth joint nearly two-thirds as long as the third; tip of the wing infuscated. Length,  $4\frac{1}{2}$ -6 mm.

Male: Face rather wide for a male, and with the sides nearly parallel, only a very little wider below; face and palpi with silvery white pollen; antennæ yellow, arista brown; front and occiput black, thickly white pollenose; orbital cilia and post-vertical bristles white. Thorax yellow, somewhat shining on the dorsum, but dulled with white pollen; humeri and pleuræ pale yellow, and covered with white pollen; pleuræ with the usual black spot in front of the halteres; scutellum and metanotum yellow; the flattened space before the scutellum sometimes slightly infuscated. Abdomen yellow with black or brown lateral spots on the dorsum of the second, third, and fourth segments, these spots sometimes united into bands on the third and fourth segments; venter yellow, with a black transverse ridge on the third segment. This ridge is ciliate with long whitish hairs, hairs on the venter yellowish white, those on the tergum mostly black; fifth segment short, and with the ventral sheath black and polished. Legs pale yellow; front coxæ with short yellow hairs on the front side, and large black bristles near the tip; middle coxæ with black hairs and bristles near the tip; front and middle metatarsi about as long as their tibiæ; front tarsi infuscated from the extreme tip of the first joint; fourth joint of front tarsi nearly two-thirds as long as third; middle and hind tarsi growing darker from the base to the tip, second joint of hind tarsi longer than the first. Wings grayish hyaline, with the apex more or less infuscated; third and fourth veins widely separated at tips; fourth vein ending slightly back of the apex of the wing.

Female: Agrees with the male in most characters, except the sexual difference, but the abdomen may lack the lateral spots; and the wings are not infuscated at apex, but somewhat tinged with yellow along the front.

Described from five males, and nine females, from Vt., N. Y., and Canada. I have taken them from the vicinity of Buffalo, N. Y., and also at Toronto, and Ridgeway, Ont.;

Prof. C. W. Johnson sent me one male, taken at Mt. Ascutney, July 11, and three females taken at Norwich, July 9; both places are in Vermont. The specimens that I took were found from June 6 to July 4.

Note.—The male of this species in general appearance resembles the male of *floridula* var. *infuscata*, but can be readily separated by the difference in venation and the greater relative length of the fourth joint of the front tarsi to the third.

I have in my collection seventeen females that seem to be a variety of this species, they were taken at East Aurora, N. Y., June 15th and 22d, 1912. They are somewhat smaller, ( $3\frac{1}{2}$ –4 mm.), and paler; some of them have sharply defined black bands on the abdomen; the third and fourth veins approach each other a very little more than in the typical forms, the fourth vein ending exactly in the apex of the wing.

There are two females in Prof. Aldrich's collection that seem to be the same as the above variety. They were taken at Battle Creek, Mich., and Ithaca, N. Y.

#### 15 *Neurigona viridis* n. sp.

Figure 15.

Thorax bright metallic green, sometimes coppery on the dorsum; abdomen mostly dark metallic green, with the first two segments partly yellow; hypopygium black, polished; front tarsi with the fourth and fifth joints a little flattened; wings with the third and fourth veins nearly parallel. Length,  $3\frac{1}{2}$ –4 mm.

Male: Eyes contiguous on the center of the face for some distance, leaving only a small triangle above and below; face and palpi silvery white; palpi rather large and with yellowish bristles at tip; proboscis yellow; front and occiput dark metallic green, with white pollen; antennæ deep yellow, the third joint a little brownish at tip, arista brown; frontal bristles black, orbital cilia and post-vertical bristles whitish. Thoracic dorsum bright shining green, sometimes with coppery reflections, and a little dulled with whitish pollen; pleuræ dark greenish, the ground color partly concealed by grayish white pollen; scutellum bright green on the disk, yellow below and usually on the lateral angles; metanotum darker green with white pollen. Abdomen with the first two segments yellow, a large dark greenish spot on the dorsum of the second, which sometimes covers most of it; the following segments dark metallic green or greenish black, with the posterior edges yellow and thickly covered with white pollen, in some specimens these edges very narrow; hairs of the abdomen mostly pale, and those on the hind margins of the segments rather long; hypopygium rather large, black, polished, and with a pair of long whitish appendages on the posterior margin. Legs pale yellowish; the hairs and bristles of the front coxæ

whitish, the bristles more brownish in certain lights; middle coxæ with black hairs and bristles; front and middle metatarsi shorter than their tibiæ; fourth joint of front tarsi flattened, fifth also slightly flattened; second joint of hind tarsi about one and one-third times as long as the first; tegulæ, their cilia, and the halters pale yellowish. Wings grayish hyaline, last section of fourth vein only feebly bent and slightly approaching the third, fourth vein ends in the apex of the wing; veins dark brown, yellow at the root of the wing.

Female: Like the male in general characters but the front tarsi are plain, the face narrow, with its sides parallel, the hairs of the front coxæ black, and the abdomen with more yellow.

Described from four males and six females from N. H., N. Y., and Va. I took the four males and two females at South Wales, Erie Co., N. Y., July 9, 1911; two of the females are from Mr. Nathan Banks, and were taken at Glencarlyn, Va., July 23; two females are in the National Museum collection, one from the White Mountains, N. H., and the other was reared by Mr. James Angus from larvæ feeding in rotten wood of hickory, at West Farms, N. Y., the imago issued May 9, 1884.

#### 16 *Neurigona decora* Aldrich.

*Neurigona decora* Aldrich, Kansas University Science Bulletin, Vol. 1, p. 83, 1902.

“Male: Eyes barely contiguous on the upper part of the face, slightly separated above and below; front broad, opaque, dark; antennæ small, red, the tip of the third joint brownish; orbital cilia pale. Thorax bright, shining blue, the concavity before the scutellum more bronze; pleuræ green, with thin dust, and the hind margin yellow; tegular cilia yellowish. Abdomen rather short, the first two joints yellow, the rest dark green, shining above. Hypopygium rather prominent, exerted, yellow. Coxæ yellow, the middle ones dark at base; remainder of legs and tarsi yellow; a slender hair on the outer side of the second joint of fore tarsus at its apex. Wings a little yellowish; the fourth vein converges toward the third at the end, terminating before the apex of the wing.

“Female: Face linear; eyes not contiguous.

“Length 2.8 to 3 mm. Two males, two females. One of the latter is from St. Vincent, but was not mentioned in the previous paper.”

I have copied the above from Prof. Aldrich's paper on the Dolichopodidæ of Grenada.



17 *Neurigona arcuata* n. sp.

Figure 17.

Thorax greenish; abdomen yellow, with black bands; hypopygium small black; wings with the costa much arcuated, and with a brown cloud along the front; front tarsi with the fourth and fifth joints black, the fifth joint nearly at right angles to the fourth. Length of male,  $3\frac{3}{4}$  mm.; of female,  $3\frac{1}{2}$ - $3\frac{3}{4}$  mm.

Male: Face silvery white, not very narrow for a male, but somewhat narrowed in the middle; proboscis yellow; front and occiput greenish, thickly covered with white pollen; frontal bristles black, orbital cilia whitish; antennæ yellow, arista brownish. Mesonotum metallic green, somewhat shining but dulled with grayish pollen, the narrow space between the acrostichal bristles more shining and without pollen; humeri and posterior angles of the dorsum yellow; pleuræ black, thickly covered with white pollen; scutellum yellow; metanotum black, a little shining, and with white pollen. Abdomen yellow, dorsum of segments two to four with wide black bands; the fifth segment has a narrow black band; hairs of the abdomen mostly yellow, including the long bristles on the hind margin of the first segment; hypopygium small, black or testaceous, polished, appendages lighter testaceous, or sordid yellow. Legs pale yellow, front coxæ bare with a few yellow bristles near the tip; middle coxæ with black hairs and bristles; front femora with a few long yellow hairs near the tip on the outside; fourth joint of front tarsi not much more than one-half as long as third, shorter than fifth, and with a few long black hairs at tip, fifth joint and most of fourth black, fifth joint nearly at right angles to fourth; front metatarsi fully three-fourths as long as their tibiæ; middle tarsi with the second, third, and fourth joints slightly flattened, becoming black from the middle of the second joint, and with the metatarsi nearly as long as their tibiæ; middle tibiæ more or less infuscated in the center; first and second joints of the hind tarsi about equal. Tegulæ and their cilia pale yellow. Wings with the costa much arcuated; posterior margin indented at the apex of the fifth vein; third vein curved backwards towards the fourth; last section of the fourth vein curved forwards from a little beyond the middle in such a manner as to be nearly parallel with the third at tip; a brown cloud along the front of the wing, from about the tip of the first vein to the tip of the third, fading out back of third vein, and widest in the middle; veins brown, yellow at the base of the wing.

Female: Agrees with the male except in the following points; all the tarsi become fuscous from the middle of the second joint; front femora have no long hairs at tip; wings with the costa less arcuated, and without distinct cloud, but the front of the wing is slightly tinged with yellowish brown; the middle tarsi slightly flattened as in the male but less so; front tarsi plain; second joint of the hind tarsi longer than the first.

Described from five specimens taken by me at Kearney, Ont., July 3, 1909; and many specimens taken in the vicinity of Buffalo, N. Y., June 6th to July 4th.

18 *Neurigona deformis* n. sp.

Figure 18.

Thorax black; abdomen yellow with black bands; hypopygium black, small; three joints of the front tarsi flattened; wings with the costa and third vein much arcuated, and with a brown cloud along the front towards the tip. Length of male 6-6½ mm., of female 5½ mm.

Male: Face not very narrow for a male, but narrowest in the center, and silvery white; front and occiput black, covered with white pollen, which is thickest on the front and upper part of the occiput; antennæ yellow, the rather long arista brownish; frontal bristles black; orbital cilia and post-vertical bristles yellowish. Thorax black, rather shining on the dorsum, thinly dusted with white pollen, this pollen much thicker along the front, on the sides, and between the acrostichal bristles; the pollen on the flattened space before the scutellum thick and somewhat greenish; pleuræ covered with white pollen, which almost conceals the ground color; humeri, posterior angles of the dorsum, space between the front coxæ, and metathoracic epimera yellow; scutellum black on the disk, yellow beneath, which color extends somewhat onto the edge of the disk; metanotum black with white pollen. Abdomen yellow; second to fifth segments with black bands at base, those on the second and third segments widest on the center of the tergum, narrowing to a point on the lateral sides; hairs on the dorsum of the second and third segments mostly black, those on the rest of the abdomen and the long bristles on the margin of the first segment yellow; hypopygium black, polished, and with its appendages more or less testaceous; sheath on the venter of the fifth segment corrugated, and opaque black. Legs long and slender, pale yellow; front coxæ with minute yellow hairs on the front, and several yellow and one or two black bristles near the tip; middle coxæ with a few black hairs and bristles near the tip; front femora with about ten long yellow hairs on the outside near the tip; middle femora nearly bare except near the tip; front metatarsi about the length of their tibiæ; second, third, and fourth joints of front tarsi flattened, bare on the sides, ciliate with black hairs on the edges, the longer hairs on the top edge longer than the width of the third joint, those on the lower edge very short, last two joints of front tarsi infuscated; middle metatarsi about equal to their tibiæ in length; middle trochanters with a black bristle; first and second joints of hind tarsi nearly equal; middle and hind tarsi black; hind tibiæ infuscated. Halteres, tegulæ, and their cilia pale yellow. Wings narrowed at the base, and with the costa much arcuated, the swell starting just before the middle; hind margin indented at the tip of the fifth and sixth veins; third vein much arcuated; last section of fourth vein nearly in a straight line with the basal part; wings hyaline, with a brownish cloud along the costa, beginning at the same point as the swell and extending to the tip of the fourth vein, fading out behind; a narrow faint cloud may be traced along the fifth, and last section of the fourth vein; veins pale yellow at the base of the wing, becoming brown on the disk.

Female: Wings with the costa nearly straight, the cloud less distinct than in the male, the whole wing being tinted with brownish in front of the third vein, and slightly clouded along the fifth vein; front tarsi plain, otherwise as in the male.

Described from four males and six females, from western N. Y. and Ont. I took the males and five females near Buffalo, N. Y., and one female at Kearney, Ont., July 8th; those taken near Buffalo were captured between June 6th and 15th.

Note.—This species is closely related to *arcuata*, but may easily be separated by its size, (this being the largest species taken so far in North America) the form of the front tarsi, and the wings, the latter being almost deformed.

### 19 *Neurigona tenuis* Loew.

Figure 19.

*Saucropus tenuis* Loew, Mon. N. A. Diptera ii, p. 228, 1864. Described from the female. The male was described by Prof. Wheeler in the Proc. Cal. Acad. Sci., ii, p. 73, 1899.

Mesonotum green; abdomen yellow, with black bands; hypopygium black, large; front tarsi about the same length as their tibiae and with an oval tip. Length  $3\frac{1}{2}$ –4 mm.

Male: Face and palpi white; eyes contiguous at the center of the face; proboscis yellow; front and occiput greenish gray, sometimes quite dark, thickly covered with white pollen; frontal bristles black, orbital cilia and post-vertical bristles pale yellow; antennae yellow, the third joint sometimes brownish, arista brown. Dorsum of the thorax light verdigris-green, shining, dulled with thick grayish pollen, that on the flattened space before the scutellum a little yellowish; humeri and more or less of the lateral edges yellow; pleurae greenish gray, with more or less yellow below, in some specimens nearly all yellow, covered with white pollen; scutellum green on the disk, with a rather wide margin of yellow; metanotum greenish gray, becoming dark brown in some individuals, white pollenose. Abdomen yellow with wide black bands on segments two, three, and four; those on the second and third narrowed laterally so as to form nearly triangular spots; fifth mostly or entirely black; first more or less brown on the dorsum; venter yellow on the basal segments, more brown or blackish toward the posterior end; hairs of the abdomen mostly black, with more pale hairs posteriorly, on the fifth segment they are altogether pale; those on the ventral surface of the fourth and hind part of third long; hypopygium black, basal part somewhat shining but dulled with white pollen, apical part, and appendages shining, polished. Legs pale yellow; front coxæ long and slender, with minute scattering hairs on the front side, and a few yellow bristles near the tip; middle coxæ with a very few black hairs or bristles near the tip, and a few yellow hairs at tip inside, these hairs curled inwards; hind coxæ usually blackened a little at tip on the inside; middle and hind femora with a few bristles on the inside near the base, those on the middle ones black, on the hind ones yellow; front meta-

tarsi about three-fourths as long as their tibiae, and about one and one-fourth times as long as the remaining joints together; second and third nearly equal; fourth and fifth fringed on each side with long black hairs, which form a flat oval tip to the tarsi, this tip a little longer than wide; fourth joint except base, and fifth black; first joint of hind tarsi a very little longer than the second; middle metatarsi about three-fourths as long as their tibiae. Tegulae, their cilia, and the halteres pale yellow, the latter with a brown dot on one side at the base of the knob. Wings grayish hyaline; third vein slightly bent backward at tip; fourth vein bent forward from just before the middle of the last section, but the tip not very close to the tip of the third.

Female: Agrees with the male except that the front tarsi are plane, with the metatarsi a little shorter than their tibiae, and more than twice as long as second joint; first and second joints of hind tarsi about equal; the mesonotum often nearly all yellow, except the flattened space before the scutellum.

Redescribed from many specimens taken in the vicinity of Buffalo, N. Y. This is the most abundant species of *Neurigona* around Buffalo, I have taken nearly one hundred specimens the past summer, the first on July 9th, and the latest on September 8th; the only other specimen I have seen is a male form Mt. Tom, Mass., taken July 14th, and sent to me by Prof. C. W. Johnson. Loew's Mon. gives Middle States as the habitat.

Note.—Prof. Wheeler in his description of the male of *tenuis* mentions a row of hook-like spines along the lower surface of the front tibiae, also curved spines on the front matatarsi; I cannot detect these in our eastern specimens, although there is a row of very minute bristles or stout hairs on the lower surface of the front tibiae that I have not mentioned in the description I have given above, because they are so easily overlooked that they are of little value in separating the species, but in the closely related western species that I am describing under the name of *pectoralis* these bristles are a conspicuous character. The males of these two species are so nearly alike in general appearance that he may have confused them. They may be separated by the front tarsi of *tenuis* being nearly as long as their tibiae, while in *pectoralis* the tarsi are much shorter than their tibiae; in *tenuis* also the front legs are infuscated from, or before the middle of the tibiae, in *pectoralis* there is no infuscation of the front legs except the enlarged tip of the tarsi which is black; *pectoralis* has the first and second joints of the hind tarsi equal, while in *tenuis* the first joint is a little the longest; the middle coxae of *pectoralis* have yellow bristles which are not found in *tenuis*.

20 *Neurigona pectoralis* n. sp.

Figure 20.

Dorsum of the thorax metallic green; abdomen yellow with black bands; front tarsi much shorter than their tibiæ and with the last two joints flattened and fringed forming an oval tip; hypopygium black, rather large. Length 4 mm.

Male: Eyes very narrowly separated; face and palpi covered with white pollen; proboscis yellow; front and occiput light metallic green, the front thinly and the occiput more thickly covered with white pollen; antennæ yellow, arista yellowish brown; frontal bristles black, orbital cilia and post-vertical bristles whitish. Dorsum of the thorax light verdigris green, with yellowish pollen; pleuræ black with whitish pollen; humeri yellowish; scutellum yellow, with the base dark metallic greenish blue; metanotum black, with white pollen. Abdomen yellow, first segment more or less infuscated, second and third segments with black bands, which are widest on the center of the dorsum, and are narrowed laterally, hardly reaching the lower sides of the abdomen; fourth segment with only the hind margin yellow, fifth entirely black except a narrow white hind margin, interrupted on the center of the dorsum, and reaching about half way to the lateral sides; hairs of the abdomen mostly black on the dorsum, those on the lower part of the sides pale. Hypopygium black, rather large, rounded behind, the first half but little shining, appendages black or testaceous. Legs pale yellow; front and middle coxæ with only yellowish hairs and bristles on the front side; front pair rather long, middle and hind coxæ slightly darkened on the outside; front tibiæ about one and one-fourth times as long as their femora, and the front tarsi hardly as long as their femora; metatarsi a little longer than the four remaining joints together, second and third joints nearly equal and very slightly flattened, fourth and fifth black, flattened and fringed on each side with black hairs, forming a nearly round tip to the tarsi; front tibiæ and metatarsi with a row of small, hook-like bristles below; middle femora with a few black bristles near the base below; middle metatarsi about four-fifths as long as their tibiæ; first and second joints of the hind tarsi of nearly equal length, hind tarsi shorter than their tibiæ; halteres, tegulæ, and their cilia pale yellow. Wings grayish hyaline, fourth vein ending in the apex of the wing; tips of the third and fourth veins quite widely separated.

Female: Agrees with the male, except that the hairs and bristles on the front of the middle coxæ are all black; the middle metatarsi are hardly three-fourths as long as their tibiæ, and the front tibiæ are about the same length as their femora and much shorter than their tarsi which are plane, and have the last joint blackened.

Described from two males and two females from N. M. in the National Museum collection, the two males and one female were taken by H. S. Barber, at Las Vegas, N. M., Aug. 7th, 9th and 13th; and the other female was taken by Townsend on the White Mountains, N. M., at 6500 feet altitude.

Note.—Under *tenuis* I have given the characters that separate the males of these two species; the females of these species can be distinguished from those of *tenuis* in having only the humeri yellow, the pleuræ being altogether black, and the dorsum dull greenish, while in *tenuis* there is more or less yellow on the dorsum and pleuræ.

21 *Neurigona æstiva* n. sp.

Figure 21.

Thorax blackish; abdomen yellow with black bands; hypopygium black with the upper part more or less yellow; front tarsi plane. Length  $5\frac{1}{2}$  mm.

Male: Face narrow, of nearly equal width throughout, face and palpi silvery white; proboscis and antennæ yellow, the latter with the third joint very small; arista brown; front and occiput blackish, but the ground color concealed by white pollen; orbital cilia whitish; post-vertical bristles yellow. Thorax and metanotum blackish with white pollen, shining on the dorsum, pollen thickest on the pleuræ and the flattened space before the scutellum; humeri, a large spot at the insertion of the wings, and the scutellum except the base yellow; metathoracic epimera yellowish white; most of the bristles of the dorsum small and weak, the acrostichal bristles can hardly be traced in some individuals, but in others they are distinct. Abdomen yellow, the first segment more whitish; second segment with a black band near the base; third with a black band at the base; fourth black at base getting paler posteriorly; fifth segment dusky yellow, with the ventral sheath large and black; hairs of the abdomen and the bristles on the hind margin of the first segment yellow, those on the lower part of the fourth segment long; hypopygium mostly black or testaceous, shining, sometimes the first half partly yellowish. Legs yellowish white; hind femora more yellowish; hairs and bristles of the front coxæ all whitish, those of the middle coxæ black; front tarsi more than twice as long as their tibiæ, their metatarsi hardly as long as the tibiæ, and about equal to the second and third joints taken together; middle metatarsi four-fifths as long as their tibiæ; second joint of the hind tarsi longer than the first; all the tarsi slightly darker towards the tip. Wings hyaline, slightly tinged with yellowish along the front; third and fourth veins quite widely separated at the tips; fourth vein ending in the apex of the wing.

Described from three males from N. Y., Md., and Vt. I took the type specimen at Lancaster, N. Y., June 2, 1912; Prof. C. W. Johnson has sent me one which was taken at Norwich, Vt., July 7, 1908; and there is one in the National Museum collection taken on Plummers Island, Md., May 11, 1905, by Mr. Schwarz.

**22 *Neurigona bivittata* n. sp.**

Figure 22.

Thorax dark reddish yellow, almost brown, with thick gray pollen, and two brown vittæ. Abdomen yellow banded with black. Length 5 mm.

Female: Face broad, whitish pollenose, the yellow ground color showing through in the specimens before mé, especially below the suture, antennæ with the first two joints pale yellow, the third more orange yellow, arista brown; front and occiput black, thickly white pollenose; orbital cilia whitish. Dorsum of the thorax dark reddish yellow, almost brown, and somewhat livid, but so thickly covered with gray pollen as to hide the ground color in unrubbed specimens, humeri pale yellow, there are two brown vittæ running from the front of the mesonotum to the flattened space before the scutellum. They are just outside of the acrostichal bristles, leaving the space between these bristles gray pollenose; these vittæ are wider posteriorly and not so sharply defined; pleuræ blackish with a reddish or livid tint, and thickly covered with white pollen; scutellum pale yellow; metanotum black with white pollen. Abdomen yellow with black bands at the base of second to fifth segments, these bands narrowed laterally, and emarginate at the center of the dorsum; venter yellow; hairs of the abdomen black; the long bristles on the first segment have a yellowish color in some lights. Legs pale yellow; front coxæ with very short hairs on the front side, which appear dark colored, and with one yellow and several brown bristles near the tip, the brown bristles having more or less of a yellow color in certain lights; middle coxæ with black hairs and bristles which are more abundant than in some species; front femora, tibiæ, and metatarsi about equal in length, the last four joints of the front tarsi together about the same length as the metatarsi; middle metatarsi shorter than their tibiæ; hind tarsi about equal to their tibiæ in length, the second joint distinctly longer than the first; last joint of all the tarsi slightly infuscated. There are the usual whitish bristles above the front coxæ. Wings grayish hyaline; veins yellowish brown; anal angle not prominent; tips of the third and fourth veins well separated, the fourth ending in the tip of the wing. Halteres short, with the knob large.

Described from two females. The type specimen is labeled Colorado; the other is from Bear Lake, B. C., and was taken by R. P. Currie, July 20, 1903; both of these specimens are in the National Museum collection.

**23 *Neurigona tarsalis* n. sp.**

Figure 23.

Thorax black; abdomen yellow with three black bands; hypopygium yellow and black; third joint of front tarsi pure white, fourth and fifth joints black and flattened. Length  $4\frac{1}{2}$  mm.

Male: Face narrow in the center, a little wider above and below; face and palpi silvery white; proboscis and antennæ yellow, arista brown; front and occiput black, thickly covered with white pollen; orbital cilia

and post-vertical bristles yellowish. Dorsum of the thorax black, and thickly covered with white pollen, which generally forms two obscure narrow stripes; pleuræ black, covered with white pollen; prothorax, humeri, and metathoracic epimera yellowish white; scutellum pale yellow, black at base; metanotum black. Abdomen yellow, with the first segment and the posterior edges of the second, third, and fourth, and the venter paler; second, third, and fourth segments with wide black bands at base, that on the second narrowed laterally; fifth segment yellow with a polished black sheath on the venter; third segment with a black transverse line on the venter, this line near the middle of the segment and fringed with long whitish hairs; hairs of the abdomen mostly pale; the long bristles on the hind margin of the first segment black; hypopygium rather large, basal half yellow, the remaining part black and polished. Legs pale yellow; front coxæ with delicate pale hairs on the front side, and black bristles near the tip; middle coxæ with black hairs and bristles; middle trochanters with a black bristle below, and a black spot above; front metatarsi a little shorter than their tibiæ, the third joint as long as the fourth and fifth together, fourth nearly twice as long as fifth, third a little enlarged, snow white, and with white hairs; fourth and fifth black, flattened, and fringed with black hairs; middle metatarsi about the length of their tibiæ; second joint of hind tarsi a little longer than the first. Wings hyaline; tips of the third and fourth veins not very close together.

Female: Differs from the male in having the face quite wide, the front tarsi plane, middle trochanters without the black spot, fifth segment of the abdomen with a black band, wings tinted with yellowish along the front and the dorsum of the thorax more greenish.

Described from twelve males and twelve females, from N. Y., Pa., and Mich. I have taken sixteen specimens at East Aurora, Erie Co., N. Y., from June 11–15. Mr. Nathan Banks took one at Sea Cliff, N. Y. Prof. J. M. Aldrich sent me specimens from Battle Creek, Mich., and Pa.

#### 24 *Neurigona lienosa* Wheeler.

*Neurigona lienosa* Wheeler, Proc. Cal. Acad. Sci. 3d series, 2, p. 72, 1899.

Length  $4\frac{3}{4}$  mm., wing  $3\frac{3}{4}$  mm.

“Proboscis yellow; palpi and face yellow, covered with silvery white dust, the latter of the usual breadth for a female; antennæ yellow, the small third joint with a blunt point, and covered with dark pubescence; arista distinctly pubescent; front and occiput metallic green, thickly covered with white dust; postocular cilia snow white. Thorax dull metallic green, the ground color almost hidden under a thick coating of brown dust; dorsal bristles prominent along the interior border of the thorax; scutellum slightly lighter metallic green, but also with a covering of dust, the scutellum bears two strong mesial, and two weak lateral bristles; first abdominal segment dark brown, succeeding segments black, dusted with white, posterior edges of second, third, and fourth segments, and venter yellow, ovipositor yellow at the base, tip



black, with delicate hairs; pleuræ blackish metallic green, thickly covered with white dust; metathoracic epimera dark brown. Coxæ yellow, fore and middle pairs with prominent black bristles on their anterior surface near their tips, hairs on upper portion of fore coxæ delicate and pale, hind coxæ with a single black bristle on its outer surface. Legs pale yellow, with black hairs, tarsi infuscated towards their tips, fore tarsi scarcely twice as long as the fore tibiæ, middle ones one and one-third times as long as the middle tibiæ, hind tarsi scarcely as long as the hind tibiæ, hind metatarsi distinctly shorter than the succeeding joint. Wings grayish hyaline with a yellowish tinge, broader in the middle, slightly narrowed towards the base; distal segment of fourth vein moderately bent forwards near its middle and ending not very close to the third vein; distal segment of fifth vein nearly two and one-half times as long as the posterior cross-vein. Halteres and tegulæ dark brown, the latter with pale cilia."

I have not seen this species and have copied this from Prof. Wheeler's description, which was made from a single female specimen taken sweeping in pine woods at Monterey, Cal., July 22, 1896.

## 25 *Neurigona lateralis* Say.

Figure 25.

*Medeterus lateralis* Say, Proc. Acad. Nat. Sci. Phila., Vol. vi, p. 169, 1829; Compl. Works, ii, p. 362.

*Saucropus superbiens* Loew, Mon. N. A. Diptera, ii, p. 227, 1864; Neue Beitr., vol. viii, p. 76, 1861.

*Dactylongia gracilipes* Aldrich, Kans. Univ. Quat., vol. ii, p. 151, 1894.

Thorax verdigris green; abdomen yellow with more or less brilliant metallic green; hypopygium yellow; front metatarsi longer than their tibiæ remaining joints very short; first joint of hind tarsi longer than second. Length of male 2-3 mm., female  $2\frac{1}{2}$ - $3\frac{1}{2}$  mm.

Male: Face narrow, silvery white, its sides nearly parallel; palpi and proboscis yellow; antennæ yellow, third joint a little infuscated, arista dark brown; front blackish, occiput greenish, both thickly covered with white pollen; frontal bristles black, orbital cilia whitish. Thorax dark verdigris green, somewhat coppery on the sides, grayish pollenose, except a narrow central line between the acrostichal bristles; scutellum more blue green, thickly gray pollenose; pleuræ and metanotum greenish black with whitish pollen; metathoracic-epimera yellow. Abdomen yellow on the venter and lateral margins, generally the dorsum of the first segment more or less yellow, fifth yellow on the hind margin, and usually some of the incisures yellow, the rest brilliant metallic green, or blue green, rarely coppery, sometimes the green reduced to lateral spots, in one female before me there is scarcely a trace of green, but four lateral coppery spots; hairs of the abdomen pale; hypopygium rounded, yellow, with whitish appendages. Legs pale yellow; all the fifth tarsal joints black; front coxæ with long delicate yellowish hairs on the front, and a few yellowish bristles near the tip, these bristles blackish in certain lights; middle coxæ nearly bare; front metatarsi longer than

their tibiæ, remaining four joints together about one-fifth, or one sixth as long as the first, third and fourth not much longer than broad, second about the length of the two following, the third with a long hair at tip; middle metatarsi about as long as their tibiæ; first joint of hind tarsi longer than the second. Wings hyaline, little tinged with grayish; third vein only slightly curved at tip, last section of fourth vein approaching third from the cross-vein slightly sinuous, the tip not far from the tip of third, ending in front of the apex of the wing.

Female: Front tarsi normal, with the first joint about three-fourths as long as their tibiæ, front coxæ with yellow hairs and black bristles; first and second joints of hind tarsi about equal; otherwise as in the male.

Redescribed from many specimens. Ont., Que., N. H., Mass., Fla., Ind., Mich., Ill., S. D., and Washington, D. C.; taken during June, July, and September.

Note.—Dr. Loew in his description of this species says that the upper orbital cilia are black, but I can see only pale cilia in the specimens I have examined.

## 26 *Neurigona setosa* n. sp.

Figure 26.

Thorax dull green; abdomen yellow with black bands; hypopygium yellow; middle and hind coxæ with a prominent black bristle on the outside. Length 3-3¼ mm.

Male: Face narrow, of nearly equal width and silvery white; front and occiput greenish with white pollen; antennæ yellow, third joint and arista dark brown. Thorax dull greenish with yellowish pollen; the flattened space before the scutellum poorly defined, and with a depressed line in the center; pleuræ black with white pollen; humeri, meta-thoracic epimera, halteres, and the root of the wing yellow; scutellum dull green with yellowish pollen, with the lower edge yellow, and a slightly elevated central ridge on the disk; metanotum black with white pollen; acrostichal bristles distinct, in two rows. Abdomen yellow; second segment with a very narrow, the third with a wider metallic greenish black band on the hind margin; fourth and fifth segments entirely metallic greenish black; venter yellow; hairs of the abdomen yellow; the black bristles on the hind margin of the first segment rather short; fourth and fifth segments ciliate with long yellow bristles on the lower lateral edges, these bristles more brown in certain lights; hypopygium yellow, brownish on the basal edge, with several yellow and two black appendages, the latter curved, mandible like, with a blunt triangular tooth on the inner edge near the center, and with long yellow hairs on the outside. Coxæ and legs yellow; hairs and bristles on the front side of the front and middle coxæ yellow; middle and hind coxæ each with a large black bristle on the outside; middle and hind femora each with a black bristle near the tip on the outside; middle femora ciliate with short yellow bristles on the lower surface towards the

base; tarsi scarcely infuscated at tips; front tarsi longer than their tibiæ; front metatarsi little more than one-half as long as their tibiæ; middle metatarsi two-thirds as long as their tibiæ; second joint of hind tarsi longer than first. Wings grayish hyaline, veins yellowish brown; posterior cross-vein less than twice its length from the wing margin measured on fifth vein; fourth vein gradually approaching third, ending before the apex of the wing, not far from the tip of third vein.

Female: Agrees with the male in most of the characters given, except in the following points; there are several black bristles near the tip of the front coxæ; abdomen with a row of black bristles on the hind margin of each segment; fourth and fifth segments of the abdomen, and the middle femora without cilia.

Described from four males and four females in the collection of the American Entomological Society, taken at Alamogordo, N. M., May 8-15, 1902. Type No. 5258.

Note.—I place this species in this genus for the present, but it differs from the other species of the genus by having the flattened space before the scutellum less distinctly defined; by the greater development of the appendages of the hypopygium; and by the bristles on the outside of the middle coxæ, and near the tip of the middle and hind femora; also the abdomen of the male is shorter and stouter than in most species of the genus.

### 27 *Neurigona tibialis* n. sp.

Figure 27.

Thorax yellow, with more or less greenish gray on the dorsum; abdomen yellow with black bands; hypopygium yellow, and very small; front tibiæ with a row of bristles above; wings with the third and fourth veins nearly parallel. Length  $2\frac{1}{2}$  mm.

Male: Face and palpi with white pollen, the former very wide for a male; antennæ yellow, first joint short and with three or four hairs above; third joint missing; front and occiput dark greenish gray, with white pollen; post-vertical bristles and some of the upper orbital cilia black, the lateral and lower orbital cilia whitish. Thorax yellow, with dark greenish gray on the center of the dorsum, which almost forms three broad vittæ, lateral ones abbreviated in front, and all somewhat united; pleuræ with a black spot above the middle coxæ, and another in front of the halteres; scutellum and metanotum dark greenish gray, the former yellowish below; acrostichal bristles rather long but scattering, forming two poorly defined rows. Abdomen yellow, incisions black on the dorsum, this black extending forward so as to almost connect along the center of the dorsum on the second, third, and fourth segments; fifth segment all black on the dorsum and with a greenish luster; venter yellow; hypopygium dark yellow, very small, and with two pair of short, slightly hooked appendages. Legs pale yellow; front coxæ with pale yellow hairs and bristles, the larger bristles blackish in certain lights; middle coxæ with black hairs and bristles, one of the

latter rather long and placed high up almost on the outside; hind coxæ with one black bristle on the outside; front tibiæ with a row of black bristles above, these bristles do not reach either the base or apex; front tarsi about one and one-half times as long as their tibiæ, the metatarsi two-thirds as long as the tibiæ, second joint half as long as the first; middle tarsi a little longer than their tibiæ, the first joint one-half as long as the tibiæ; middle and hind femora with a black bristle near the tip on the outside; hind tarsi fully as long as their tibiæ, with the second joint longer than the first. Wings grayish hyaline; third and fourth veins only very slightly convergent at the tips.

Described from one male which I took at Lancaster, Erie Co., N. Y., on Aug. 15, 1909.

Note.—This species resembles *setosa* in having a bristle on the outside of each middle and hind coxæ, and near the tip of each middle and hind femora; also in having bristles on the hind margin of all the segments of the abdomen. The hypopygium is smaller than that of any other species of the genus that I have seen. There are three or four bristly hairs on the top of the first joint of the antennæ near the tip, but this joint is hardly hairy on top in the same way that it is in some of the genera of Dolichopodidæ.

#### 28 *Neurigona ciliata* n. sp.

Figure 29.

Dorsum of the thorax black; abdomen yellow with black bands; hypopygium small, black; front tarsi black, fringed on each side with short black hairs; wings strongly tinged with brown in front of the third vein. Length  $4\frac{1}{2}$  mm.

Male: Face and palpi silvery white, the former very narrow, the eyes almost touching on the center of the face; proboscis and antennæ yellow, arista yellowish brown; front and occiput greenish gray, with white pollen; frontal bristles black, orbital cilia and post-vertical bristles whitish. Thorax black, shining on the dorsum, with white pollen, this pollen thickest on the flattened space before the scutellum; humeri, prothorax, lateral edges of the dorsum, scutellum except base, metathoracic-epimera, and a large triangular spot above the middle coxæ yellow. Abdomen yellow, with poorly defined, wide black bands on the dorsum at the base of segments two, three, and four, and a small spot at base of fifth; hairs black on the first four segments, pale on the fifth and on the venter; venter yellow; hypopygium small black shining, appendages testaceous. Legs pale yellow; front coxæ with pale hairs and bristles, one or two of these bristles black; middle coxæ with black hairs and bristles; front tarsi black, fringed on each side with short coarse, dense hairs, giving them the appearance of being flattened, these hairs hardly as long as the diameter of the tarsi; front metatarsi about equal to their tibiæ in length, fourth joint hardly twice as long as wide; middle metatarsi four-fifths as long as their tibiæ; middle legs

infuscated from the middle of the tibiæ, the tarsi becoming black; first and second joints of hind tarsi equal, black from the tip of the first joint. Halteres, tegulæ and their cilia pale yellow. Wings brownish hyaline, much darker in front of the third vein; veins dark brown; third vein bent backwards at tip, fourth vein bent forwards from beyond the middle of the last section, the tips of third and fourth quite near together.

Described from one male taken at Doe Bay, Wash., July 16, 1909, in the collection of Prof. J. M. Aldrich.

29 *Neurigona perbrevis* n. sp.

Figure 30.

Dorsum of the thorax grayish green, with three brownish vittæ; abdomen black; hypopygium black, polished, and rather large; front tarsi with the last two joints flattened and fringed, forming an oval tip; front tibiæ longer than their tarsi. Length  $3\frac{3}{4}$  mm.

Male: Face rather narrow; face and palpi white; front and occiput seem to be black, but the ground color concealed by whitish pollen; orbital cilia white; antennæ yellow, the small third joint and the arista brownish. Dorsum of the thorax grayish green, thickly covered with pollen, (this pollen and that of the head and scutellum has a greenish tint). Dorsum with four brown vittæ, the lateral ones abbreviated in front; scutellum the same color as the dorsum, but the edges a little yellowish; pleuræ black with white pollen. Abdomen black, covered with white pollen which is thickest on the posterior margins of the segments; fifth segment with a yellow hind margin; venter yellow; hairs on the tergum black, those on the sides of the last three segments white; hypopygium shining black, polished, and rather large; appendages shining black. Legs yellow; front and middle coxæ with yellowish hairs and bristles; middle and hind coxæ darkened on the outside; front tibiæ longer than their tarsi or femora, which are of equal length; metatarsi longer than the remaining four joints together; fourth and fifth joints black, flattened, and fringed on each side, forming an oval tip, which is nearly twice as long as wide; middle metatarsi nearly three-fourths as long as their tibiæ; hind tarsi nearly as long as their tibiæ, the second joint a little longer than the first; hind femora with a few yellow bristles below near the base. Halteres yellow; tegulæ and their long cilia whitish. Wings hyaline; fourth vein rather sharply bent towards the third, ending in the apex of the wing, not very close to the tip of the third vein; veins brown.

Described from two males in the collection of the American Entomological Society, which were taken at Alamogordo, N. M., on April 20 and May 12, 1902. Type No. 5257.

30 *Neurigona australis* n. sp.

Figure 31.

Dorsum of the thorax grayish green; abdomen with the dorsum entirely blackish; hypopygium shining black, large; front tarsi with the last two joints flattened and fringed with black hairs, forming an oval tip to the tarsi; front tibiæ shorter than their tarsi. Length of male and female  $4\frac{1}{2}$  mm.

Male: Face narrow, silvery white; palpi and proboscis yellow; front and occiput black, with grayish white pollen, the latter with purple reflections; orbital cilia white except a few of the uppermost which are black; antennæ yellow, third joint and arista brownish. Dorsum of the thorax grayish green, with some purple reflections, and grayish pollenose, with four brown vittæ, the lateral ones rather poorly defined; pleuræ and metanotum black, and covered with white pollen; a small yellowish spot below the humeri; scutellum the same color as the dorsum. Abdomen metallic black and covered with grayish pollen, which is thickest on the sides; fifth segment glabrous and shining; venter sordid yellow; hairs of the abdomen mostly pale, rather scattering, but longer and more abundant on the sides and posterior end; hypopygium shining black, large, polished, rounded behind, and with black appendages. Legs yellow; middle and hind coxæ blackened almost to the tip; front and middle coxæ with white hairs and bristles; front tibiæ and tarsi darker than their femora the tibiæ a little longer than their femora, and the tarsi nearly one and one-third times as long as the tibiæ, the last four joints flattened, fourth and fifth joints black and fringed on each side, forming an oval tip to the tarsi; front metatarsi nearly as long as the remaining four joints together; middle metatarsi about the same length as their tibiæ; a few weak yellow bristles on the lower side of the middle femora near the base; hind tarsi about the same length as their tibiæ, and the first joint longer than the second; last four joints of the middle and hind tarsi darkened. Halteres, tegulæ, and their cilia yellowish. Wings hyaline, only slightly tinged with grayish; anal angle not prominent; fourth vein sharply bent towards the third, ending in the apex of the wing, not very near the tip of the third vein.

Female: Differs from the male as follows: the abdomen is lighter colored, more like the dorsum of the thorax; the front tarsi are plane; the middle femora without bristles below; and the first and second joints of the hind tarsi nearly equal.

Described from one male, and five females from New Mexico. The male and one female are in the collection of the American Entomological Society, and were taken at Cloudcroft, N. M., June 18, 1902; in the National Museum collection are three females, taken at Las Vegas, N. M., Aug. 7, 8, and 11, by S. H. Baker; and one female taken on the White Mountains, N. M., Aug. 5th, by Townsend, at 6500 feet altitude. Type in the collection of the American Entomological Society; type No. 5256.

31 *Neurigona albospinosa* n. sp.

Figure 32.

Thorax blackish, with three metallic brown vittæ; abdomen greenish black, segments gray pollenose at base; hypopygium small, testaceous; hind coxæ with several rather weak whitish bristles. Length of male 4-4½ mm., female 3½-5 mm.

Male: Face not very narrow for a male, and with the sides nearly parallel; face and palpi white; proboscis and antennæ yellow, the latter with the third joint and the arista dark brown; front and occiput dark grayish green with white pollen; orbital cilia white. Thorax and scutellum blackish, more gray on the dorsum, and with three somewhat shining metallic brown vittæ, the central one between the acrostichal bristles most sharply defined; thorax including scutellum and metanotum whitish pollenose, the pollen more brown on the flattened space before the scutellum, this brown pollen extends somewhat onto the scutellum. Abdomen metallic greenish black with coppery reflections, and a grayish pollenose band at the base of each segment; the hairs on these bands white, on the posterior part of the segments the hairs are black; the first segment wholly gray pollenose, and with the marginal row of bristles pale except about four at the top which are black; second segment with two transverse rows of black dashes near the base; venter of the first segment, and very narrow lateral edges of one or more of the others yellow; hypopygium testaceous, polished, and rather small. Legs pale yellow; front coxæ whitish with long white hairs on the whole front; middle coxæ also with white hairs and bristles; hind coxæ with one long and several weak whitish bristles on the outside; middle and hind coxæ blackish at base; front and middle metatarsi about two-thirds as long as their tibiæ; hind tarsi with the first joint shorter than the second; middle and hind tarsi infuscated from the tip of the first joint; hind femora brownish above. Cilia of the tegulæ whitish; halteres yellow with the knob whitish. Wings brownish hyaline, darker along the front; third and fourth veins wide apart at tip.

Females: Agrees with the male in most characters, but the scutellum yellow, sometimes a little darkened at base; marginal row of bristles on the first segment of abdomen black, sometimes one or two of the lower ones yellowish; stout bristles on hind coxæ brown in some lights. Face broad, darker than in the male, and the palpi yellowish.

Described from seven males and twelve females, from Idaho, Wash., and Cal. I received from Prof. Aldrich specimens taken at Lewiston, and Juliaetta, Idaho, the latter taken May 7th; also specimens taken at Stanford University, Cal., Feb. 22 to March 24th. From Prof. Melander I received specimens from Wenatchee, Wash., taken May 8th.

32 *Neurigona minuta* n. sp.

Dark metallic green; arista white; hind coxæ with a yellow bristle on the outside. Length 2 mm.

Female: Face, front and occiput greenish black, with but little pollen (at least in the type specimen); palpi and proboscis yellow, the former with minute black hairs on the surface and a black bristle at tip; antennæ dark reddish brown, the third joint rounded, hardly pointed, and more brown than the basal joints, the arista inserted near the apex, white. Thorax rather dark metallic green, covered with gray pollen; humeri with only a trace of yellowish; the flattened space before the scutellum not very sharply defined; bristles of the thorax strong, acrostichal bristles well developed, in two rows; the outer pair of scutellar bristles minute but distinct. Abdomen dark metallic green, with black hairs; venter dark. Legs and coxæ pale yellow; front coxæ with whitish hairs and bristles; middle coxæ with brownish hairs; the large bristle on the outer surface of the hind coxæ yellow; the hairs on all the legs very minute; front and middle tarsi about one and one-half times as long as their tibiæ, their first joint being about half as long as the tibiæ; middle tibiæ with two black bristles near the base, one on the front side, and one on the outer side; hind tibiæ with a row of four or five black bristles on the posterior surface; hind tarsi a little longer than their tibiæ, and with the first joint only half as long as the second. Halteres, tegulæ and their cilia pale yellow. Wings hyaline, only slightly tinged with grayish; venation about as in *N. aldrichii* (Fig. 12), except that the posterior cross-vein is only its own length from the wing margin measured on the fifth vein, and the apical half of the last section of the fourth vein is nearly straight; veins brown, becoming pale yellow at the root of the wing.

Described from one female from Philadelphia, Pa., which was bred from decaying oak, May 23, 1907. Type in the collection of Prof. J. M. Aldrich.

Note.—This is the smallest species of the genus that I have seen, and is very distinct from all the others. It can readily be distinguished by the pale bristles of the coxæ, and its white arista.



## EXPLANATION OF PLATES.

- Fig. 1. *Neurigona rubella* Loew, wing and hypopygium of male.  
 " 2. " *perplexa* n. sp. wing and hypopygium of male.  
 " 3. " *dimidiata* Loew, wing and hypopygium of male.  
 " 4. " *carbonifer* Loew, wing, hypopygium, and tip of front tarsi of male.  
 " 5. " *nitida* n. sp. wing and hypopygium of male.  
 " 6. " *tridens* n. sp. wing of female.  
 " 8. " *maculata* n. sp. wing and hypopygium of male.  
 " 9. " *floridula* Wheeler, wing and hypopygium of male.  
 " 10. " *floridula* var. *infusata* n. var. wing of female.  
 " 11. " *flava* n. sp. wing of female.  
 " 12. " *aldrichii* n. sp. wing, hypopygium, and front tarsi of male.  
 " 13. " *transversa* n. sp. wing of female.  
 " 14. " *disjuncta* n. sp. wing and hypopygium of male.  
 " 15. " *viridis* n. sp. wing and hypopygium of male.  
 " 17. " *arcuata* n. sp. wing, hypopygium, and tip of front tarsi of male.  
 " 17a. " *arcuata* n. sp. wing of female.  
 " 18. " *deformis* n. sp. wing, hypopygium, and tip of front tarsi of male.  
 " 18a. " *deformis* n. sp. wing of female.  
 " 19. " *tenuis* Loew, wing, hypopygium, and tip of front tarsi of male.  
 " 20. " *pectoralis* n. sp. wing, hypopygium, and tip of front tarsi of male.  
 " 21. " *aestiva* n. sp. wing and hypopygium of male.  
 " 22. " *bivittata* n. sp. wing of female.  
 " 23. " *tarsalis* n. sp. wing and hypopygium of male.  
 " 25. " *lateralis* Say, wing and hypopygium of male.  
 " 26. " *setosa* n. sp. wing and hypopygium of male, the latter is stretched out backwards.  
 " 27. " *tibialis* n. sp. wing and hypopygium of male.  
 " 28. " *quadrifasciata* Fab. (European) apical part of wing.  
 " 29. " *ciliata* n. sp. wing and hypopygium of male.  
 " 30. " *perbrevis* n. sp. wing, hypopygium, and tip of front tarsi of male.  
 " 31. " *australis* n. sp. wing, hypopygium, and tip of front tarsi of male.  
 " 32. " *albopinosa* n. sp. wing, and hypopygium of male.

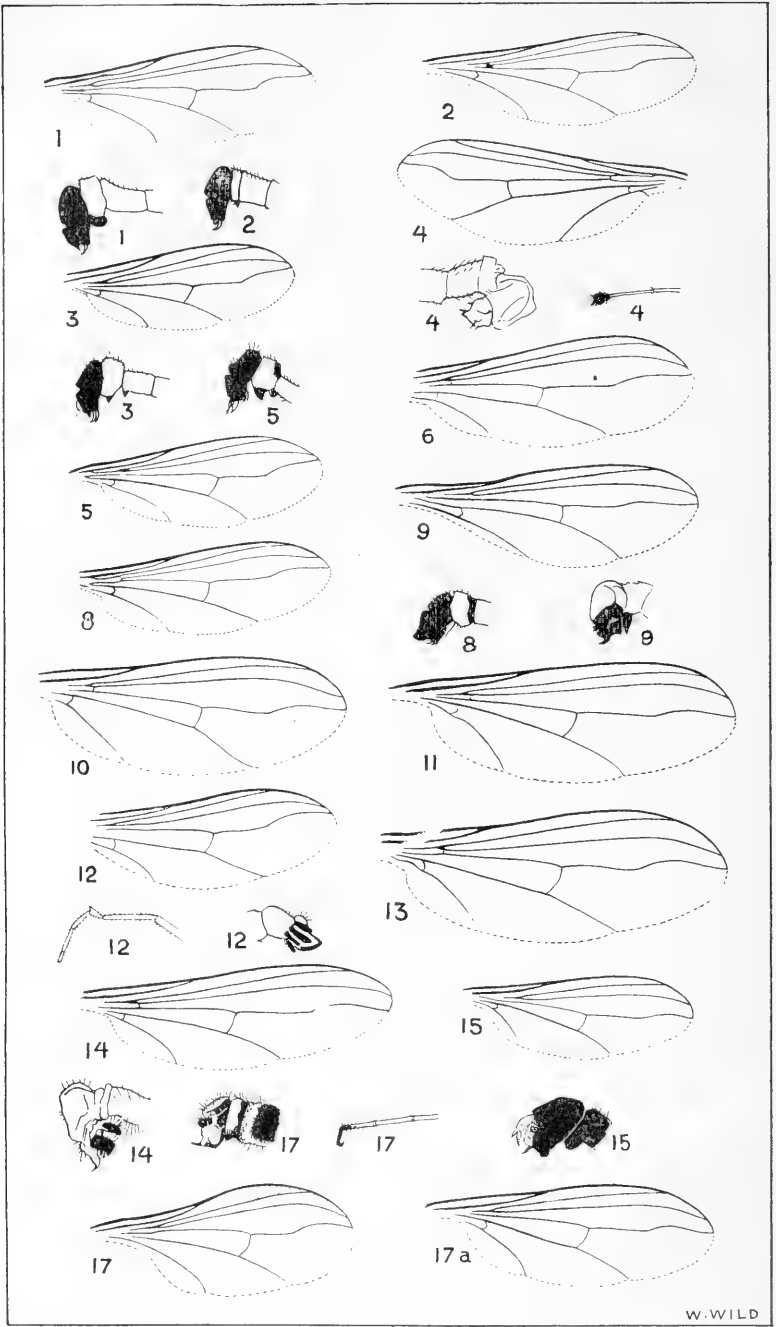

W. WILD

M. C. Van Duzee.

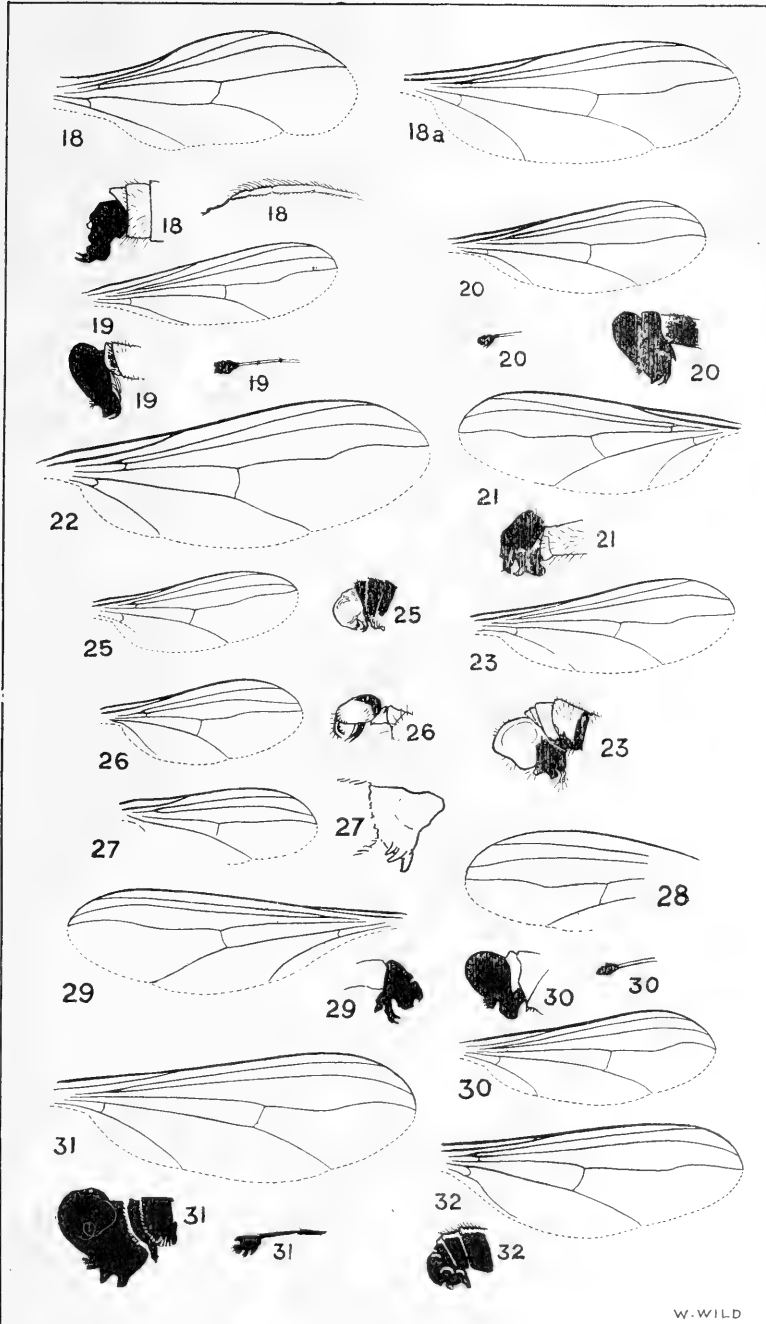

W. WILD



# AN INTERESTING FEATURE IN THE VENATION OF HELICOPSYCHE, THE MOLANNIDAE, AND THE LEPTOCERIDAE.

By CORNELIUS BETTEN, Lake Forest College.

The conclusions recorded in a recent paper by Prof. Martynov\* regarding the venation of the Trichopterous genus *Helicopsyche* lead me to anticipate here one of several somewhat revolutionary views on the venation of the Trichoptera to which I have come during the progress of work on a rather extended report on that order of insects.

For the sake of comparison a figure is here given of the venation of the fore wing of *Rhyacophila* (Fig. 1), representing an extremely primitive type. The homologies indicated in this figure are so simple as to require no comment except as regards the branches of subcosta (Sc) and of cubitus and the anals. None of these is here considered and attention is directed only to radius which in this genus appears in absolutely primitive condition, that is, with  $R_1$  running free to the margin and with the radial sector (Rs) dichotomously branched. In very many Trichoptera there is a cross vein from  $R_3$  to  $R_4$  setting off what is called the discal cell. Near the base of cell  $R_4$  (the cell bounded by  $R_4$  and  $R_5$ ) there is indicated a very small corneous point which is present in the vast majority of Trichopterous wings.

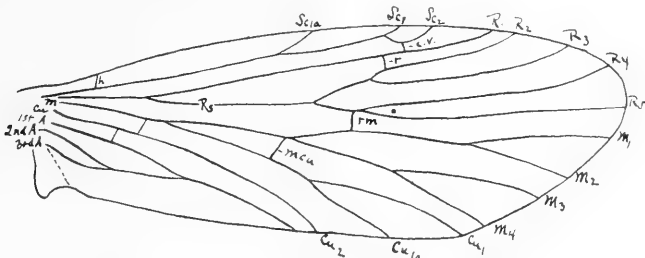

Fig. 1. Venation of fore wing of *Rhyacophila* sp.

Martynov reaches the conclusion that radius is also found in practically the typical condition in *Helicopsyche* (Fig. 2), that is, that cell  $R_4$  in both fore and hind wings is not obliterated by the fusion of  $R_4$  and  $R_5$  as might at first sight appear to be the case.

\*Martynov, A. B. On two Collections of Trichoptera from Peru. *Annuaire du Musee Zool. de l'Acad. Imperiale des Sci. de St. Petersburg*. Vol. 17 (1912), 40 pp., Figs. 1-59.

That this view is correct seems to admit of no doubt. In the American species (*H. borealis* Hag.) the relations are entirely clear.  $R_5$  leaves  $R_4$  at nearly a right angle and then again turns sharply to the wing margin; the cross vein  $rm$  meets the vein at the latter angle, and is in a nearly horizontal position. One might therefore easily be deceived into thinking that the cross vein  $rm$  and the distal part of  $R_5$  with which it is in direct line together constitute a branch of *media*. A failure to recognize the true relation has forced most authors to leave this vein unidentified in their figures. The exact position of the base of  $R_5$  varies somewhat within the genus and also within the species;

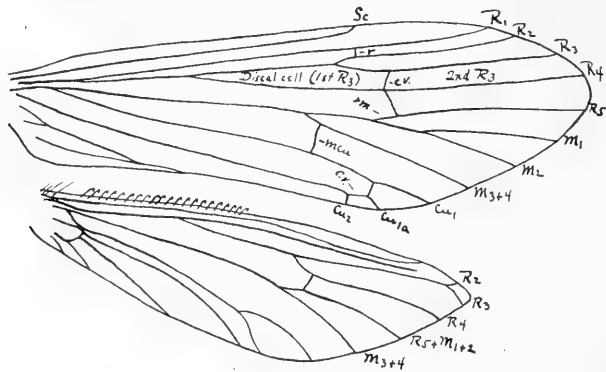

Fig. 2. Venation of *Helicopsyche borealis*.

in specimens of *H. borealis* (Fig. 2 and Fig. 3a) the cross vein  $rm$  is left intact though out of the usual position as already shown, in Martynov's figure (l. c., Fig. 2, copied in Fig. 3b) of *H. minuscula* the angle in  $R_5$  just touches  $M_{1+2}$  so that the cross vein  $rm$  is obliterated and its function is assumed by the base of  $R_5$ , in Ulmer's figure of *H. borealis* (Genera Insect. Fasc. 60, pl. 11, fig. 98, copied in Fig. 3c) the base of  $R_5$  has migrated still farther back so as to be still more deceptive in its resemblance to the cross vein which it has displaced. Ulmer has recently described some related fossil genera in one of which (*Palaeohelicopsyche*\*) the female has the cross vein  $rm$  present while it has been displaced in the male.

\*Ulmer, Georg. Die Trichopteren des baltischen Bernsteins. Schriften der physikalisch-ökonomischen Ges. zu Königsberg. Beiträge zur Naturkunde Preussens. Heft 10 (1912), p. 308.

Attention has already been called to the small corneous point that occurs in the base of cell  $R_4$  in almost all Trichoptera. Perhaps the position of this point may be given some weight in the determination of the veins between which it occurs, as is done in the discussion of the venation of the Molannidæ and the Leptoceridæ given later in this paper. In the case of *Helicopsyche* the evidence from this source now available is incomplete and apparently contradictory. In Ulmer's figure of the closely related genus *Tetanonema* (Genera Insect. Fasc. 60, pl. 12, fig. 100) the corneous point appears in its normal position in cell  $R_4$  but in his figure of *H. sperata* (l. c., pl. 11, fig. 97) and in the figures of several related genera

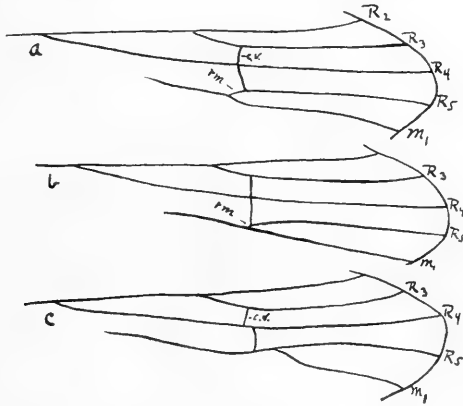

Fig. 3. a, Radius of the fore wing of *Helicopsyche borealis*. b, The same from *H. minuscula* (after Martynov). c, Another specimen of *H. borealis* (after Ulmer).

described in his fine work on the fossil forms it is found in cell 2nd  $R_3$ , that is, in the cell immediately anterior to the one in which it normally occurs. On the other hand this spot is not shown in McLachlan's figures of *H. sperata* and *H. borealis*, Martynov does not find it in *H. sperata* and the study of a large series of *H. borealis* fails to reveal a single occurrence. Since Ulmer's observations are on material in amber there may be greater chance for error though it seems unlikely that this should happen in several cases. At any rate, *Tetanonema* and *Saetotricha*, the only closely related modern forms, should be re-examined in this connection. If Ulmer's figures are correct these cases form the only exception to the rule that the corneous

point occurs, if it occurs at all, in the base of cell  $R_4$ . In some groups there is a similar spot in the distal part of cell  $M$  of the fore wing (Fig. 8). This spot which has apparently been but little noted, while it is characteristic of fewer groups of Trichoptera is as constant in position as are those of cell  $R_4$  in the fore and hind wings.

On account of the reduced number of segments in the male palpus *Helicopsyche* has always been placed in the very heterogeneous family Sericostomatidæ though its isolated position within that family has been fully recognized. Its venation, as interpreted by Martynov, has some resemblance in the points here considered to the very abnormal venation of the Molannidæ and to that of the Leptoceridæ.

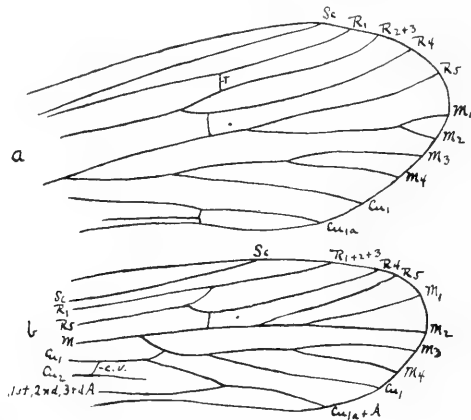

Fig. 4. *a*, Apical part of fore wing of *Molannodes zelleri*.  
*b*, Same of *Molanna cinerea* ♀.

In the Molannidæ there has come about a very considerable shifting in the position of the veins as a result doubtless of the unusual position of the wings—these being rolled more or less about the body. In the European genus *Molannodes* (Fig. 4a) the condition with respect to radius is strikingly like that which is at least sometimes found in *Helicopsyche* (Fig. 3c), that is,  $R_5$  has arched back into  $M_{1+2}$  obliterating the cross vein  $rm$  and leaving its own base in the regular position of that cross vein. There is a further reduction in the fusion of  $R_2$  and  $R_3$ . In *Molanna cinerea* (Fig. 4b) there is a similar condition but  $R_{2+3}$  has also fused with  $R_1$ . In both genera  $M_{3+4}$  has migrated



upon  $Cu_1$  just as  $R_5$  has upon  $M_{1+2}$ . Radius of the hind wing may be similarly interpreted. While the limits of this paper preclude discussion of the other modifications, enough has been indicated to show that the determination of the homologies in the venation of the Molannidæ and the Beraeinæ need not be given up in despair.

While in the case of the Molannidæ the suggestions here made may help to bring order out of what has admittedly been chaos, it may seem that in extending the same interpretation to the Leptoceridæ the reverse is true. In this latter family there has been uncertainty as to the homology of the veins but the entire family is practically homogeneous in this respect and everyone seems to have been satisfied to recognize equivalents within these limits without determining the larger relations. Thus McLachlan (Rev. and Syn. p. 282) states that the application of the notation in this family (his section 3) is "not very satisfactory" and he leaves the veins and cells between  $R_3$  and  $Cu_1$  unidentified except in the genus *Triænodes* and in the females of *Leptocerus*. In these latter cases there is apparently an evident recurrence of the 2nd and 3rd cells (cells  $R_4$  and  $M_1$ ) respectively, but as will be indicated further on this appearance may be illusory. Later authors have followed McLachlan's practice and no suggestion has so far been made as to the manner by which the evident reduction of the venation of the Leptoceridæ has come about.

The venation of a species of *Leptocerus* (Fig. 5) may serve as typical for the family. Attention is directed to radius of the fore wing which is similar in appearance in practically all members of the family and which apparently differs from the typical 5-branched radius only in having  $R_4$  and  $R_5$  fused. The only reason for questioning this interpretation is found in the fact that the corneous point then falls behind instead of in front of  $R_5$ . Exactly comparable conditions are found in the hind wing (Fig. 5b). It may possibly not be justifiable to discard the obvious interpretation of these veins because of the location of a minute structure whose significance is wholly unknown and whose position may therefore depend upon factors which have nothing whatever to do with the venation. It is, however, a most remarkable fact that while these points are absent in a few groups, they are never found outside of their respective cells no matter what curious modifications

these cells undergo. In fact a condition like that shown in Fig. 6 (*Smicridea* sp.) suggests that the corneous point submits to annihilation in preference to displacement.

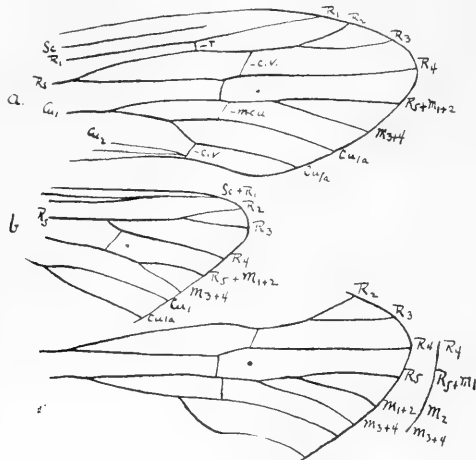

Fig. 5. a, Apical venation of fore wing of *Leptocerus* sp. ♂. b, Hind wing of same. c, Fore wing of female of same.

If then we give any weight to the comparison with *Helicopsyche* and the *Molannidæ* and to the position of the corneous points we should conclude that in the *Leptoceridæ* also  $R_5$  has arched into  $M_{1+2}$  its distal end fusing with the latter compound vein and that what appears to be the cross vein  $rm$  is in reality the base of  $R_5$ .



Fig. 6. Radial sector in the fore wing of *Smicridea divisa*.

In almost all of the *Leptoceridæ* media is reduced to two branches but in the subfamily *Triplectidinae* and in females of the genus *Leptocerus* a more generalized condition obtains, that is, media is apparently three branched (Fig. 5c). If the view here advocated is correct these generalized *Leptoceridæ* are in exactly the same condition as regards the relation of  $R_5$  and media as is *Helicopsyche*, that is,  $R_5$  has arched into  $M_{1+2}$  but has not fused with it distally. There is of course the other possibility that it is  $M_1$  and  $M_2$  that are separate and  $R_5$  and  $M_1$

that have fused. The alternative interpretations are indicated in Fig. 5c. To decide between these possibilities we should have to find out which fusion took place earlier in the phylogenetic series and on this question the evidence seems inconclusive.

While the purpose of this paper is fulfilled in showing that the modifications of radius may be similarly interpreted in *Helicopsyche*, the *Molannidæ*, and the *Leptoceridæ*, another instance of similar modifications may be added lest the basal shifting of a distal branch from one main stem to another should seem unlikely in this order: A parallel case is shown in *media* of the fore wing of *Oecetis*\*. Authors from McLachlan

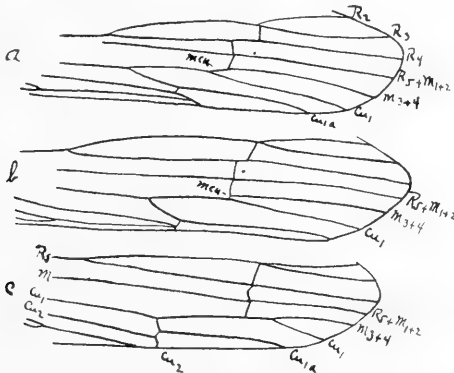

Fig. 7. Venation of apical part of fore wing of species of *Oecetia*. a, *Oecetia fumosa*. b, *Oecetia incerta*. c, *Oecetia testacea* (after McLachlan).

on agree in saying that *media* in *Oecetis* is absolutely simple or unbranched. No one seems to have been disturbed by the fact that on such an interpretation an extra branch would have to be assigned to cubitus. As a matter of fact *media* is always two branched in *Oecetis* as it is in most of the other *Leptoceridæ*. In *O. fumosa* (Fig. 7a) while there is slight variation in exact position,  $M_{3+4}$  leaves  $M_{1+2}$  at about right angles; it bends sharply and then proceeds to the wing margin. At the latter angle it is joined by the cross vein m-cu which is in line with the distal end of  $M_{3+4}$  so that the resulting deceptive appearance is that of an extra branch on the anterior side of cubitus joined to *media* by a cross vein which is in reality the base of  $M_{3+4}$ . In *O. incerta* (Fig. 7b) the cross vein m-cu is very short, in some

\*I include here *Oecetina* Banks and *Oecetodes* Ulmer.

specimens it is wholly lacking. Finally in such forms as the European *O. testacea* (Fig. 7c) the base of  $M_{3+4}$  has migrated farther back on  $Cu_1$  and in this position its true nature as a part of  $M_{3+4}$  is far from obvious. In such a case the vein becomes virtually a cross vein and migrates according to the mechanical stress in flight without reference to the distal part of the vein which is left stranded with a new basal connection. Other instances of this sort occur in the Trichoptera and they are not uncommon in other orders.

The facts here presented may be of some significance in their bearing on the question of the systematic position of the Helicopsychinæ. This subfamily has always been placed in the Sericostomatidæ because of the unequal number of segments in the palpi of the male and female, though it has always been clearly recognized that it bears no close relationship to any of the heterogeneous groups included in that family. Thienemann, Ulmer, and Martynov have each suggested that a new subfamily should be erected for the genera *Helicopsyche*, *Tetanomena*, and *Saetotricha*, and Ulmer and Martynov have during the past year almost simultaneously described the subfamily Helicopsychinæ, Ulmer's description being slightly the earlier.

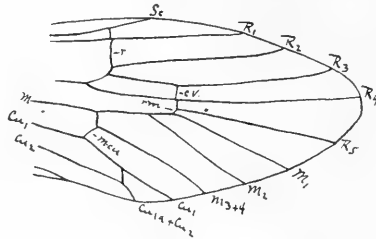

Fig. 8. Venation of apical part of fore wing of *Sericostoma* sp.

In his recent work on the fossil forms Ulmer lists the Helicopsychinæ among the Sericostomatidæ but in this work (p.376) he makes the first suggestion that these forms may possibly show affinities to the Leptoceridæ though he gives, so far as I can find, no reason for the statement. What has been given above certainly confirms the impression which Ulmer has stated since in the Helicopsychinæ, the Molannidæ, and the Leptoceridæ,  $R_5$  shows an increasing tendency to migrate upon  $M_{1+2}$ —a condition not seen elsewhere in the Trichoptera, though the sharp angle in  $R_5$  seen in *Sericostoma* (Fig. 8) and other forms might be regarded as a beginning of that tendency.

It is interesting to note that there are some other characters not found in the Sericostomatidæ which *Helicopsyche* shares with genera of other families. Thus it has the costal hooks on the hind wings which are found well developed only in the Leptoceridæ, Molannidæ, and the Macronematinae (Hydropsychidæ). I find also that *H. borealis* has the peculiar fenestrated terga in the posterior abdominal segments heretofore found only in certain species of *Oecetis*—a genus of Leptoceridæ.

Taken altogether the facts presented do not do more than emphasize the isolated position of the Helicopsychinæ and suggest that this subfamily may be regarded as an early offshoot from the Leptocerid stem which in the condition of the palpi has diverged from the typical form in the same way as have the Sericostomatidæ.

# HOMOLOGIES OF THE WING VEINS OF THE MEMBRACIDÆ.<sup>1</sup>

W. D. FUNKHOUSER.

## INTRODUCTION.

Since in problems of phylogeny and taxonomy of insects the homologies of the wing-veins are being taken more and more into consideration, it is evident that the available data on this subject should be as complete as possible.

In the work which has been done along this line, certain families of the Homoptera have received but little attention and of these the Membracidæ appear to have been entirely neglected. For this reason, and because of a large personal interest in this group of bizarre insects, this study has been undertaken, hoping that it might be possible to add in some measure to the knowledge of hemipterous wings.

The work was begun two years ago at the suggestion and under the direction of Dr. MacGillivray, then of Cornell University, and has been completed under the supervision of Dr. Bradley, of the Entomological Department of Cornell, to both of whom I am greatly indebted for their most helpful criticisms and suggestions and for access to the specimens in the Cornell collection for examination and comparison.

## METHOD.

Of the various methods of approaching the subject of wing-vein homologies, the Comstock-Needham theory<sup>2</sup> that the study should be based on the ontogenetic consideration of the tracheæ which precede the veins has been so fully established and is so applicable to the membracid wing that any other method of procedure in the examination of this highly specialized and complex homopterous type would appear to be the merest guess-work. It has been a source of the greatest satisfaction in the application of this theory to find that the nymphal tracheation has proven in most cases an open index to the adult venation, while the variation and peculiarities of many veins can be traced directly to the behavior of the tracheæ which preceded them.

1. Contribution from the Entomological Laboratory of Cornell University.
2. The Wings of Insects, Am. Nat. XXXII and XXXIII, 1898, 1899.

According to this theory the knowledge of homologies is dependent upon two methods of investigation. First, the ontogeny of the wing of the individual, as based on the study of the tracheation of nymphal wings traced through their successive stages of development, and second, the study of the wings of adults worked out by careful comparison with forms representing known types of venation. Of these two methods, the former has been the one used almost entirely and the second has been resorted to only for those forms for which the nymphs were not available. Since, however, the venation of the Membracidæ is comparatively uniform, the determination of homologies, after the tracheation of the nymphs of the more prominent types has been ascertained, has proven a relatively simple matter.

#### TECHNIQUE.

The laboratory methods followed have been in the main those outlined in the "Wings of Insects"<sup>3</sup> with such modifications as have been suggested by the condition and shape of the individual wings under consideration.

The wings were dissected from nymphs of various stages of development, but it was found that in most cases the last two instars showed best the features desired. In these two instars the nymphal wings may be pulled out of the wing-pads and are thus more easily studied. In the earlier stages, and in all of the stages of some of the smaller species, e. g. *Vanduzee* *arquata* or *Micrutalis calva*, it is difficult to remove the wing from the pad without disturbing the position of the tracheæ, and in these cases it is necessary to photograph through the pad membrane. The wings were carefully dissected out, together with a portion of the thorax to show the basal tracheation, and mounted at once. It was found that fresh material gave much better results than that which had been preserved, even for a short time, in formol or alcohol. In many cases, several hundred dissections were made for the verification of some particular point in question. The greatest difficulty was to preserve the tracheæ for a sufficient length of time to secure photomicrographs or careful drawings, since the tracheæ fill in a very short time with the mounting media and are then invisible. Moreover,

3. American Naturalist, Vol. XXXII, p. 45.

in the membracid wing, there is a sharp bend at the point at which the tracheæ enter the body and it is difficult to secure a mount in which the base and tip of the wing are in focus at the same time.

Various mounting media were tried, but for the wings of this family glycerin jelly was uniformly the most satisfactory. A drop of jelly was placed on the slide, the wing laid in the jelly, another drop placed on the cover-slip and the latter placed at once over the specimen. The mount was then quickly cooled by placing a drop of ether on the cover-slip and fanning it to insure rapid evaporation. Some of the mounts made in this way have remained in good condition for over a year and bid fair to last for a much longer period.

Photomicrographs were then made of the specimen, using whatever combination of objective and bellows were necessary to bring out the desired details and to make the image fill a 5x7 plate. Since many of the nymphal wings are less than two millimeters in length, the magnification is necessarily great, but negatives can usually be secured sufficiently sharp to show the points in question. Artificial light, secured by means of a Nernst lamp and series of condensers, seemed to be more desirable than sunlight for this work, mainly owing to the fact that it was possible to secure a chart of uniform exposures for the different magnifications.

In cases where photomicrographs were not considered necessary, careful camera lucida drawings were made, verified by repeated comparisons. For the adult wings, the permanent mounts (Canada balsam) of the wings themselves were used, copied by projection drawings when figures were desired.

Velox and solio prints from all negatives were made for permanent records in this study. The figures of nymphal wings shown in this paper, however, are blueprints inked in with india ink and afterwards bleached.<sup>4</sup> The figures of adult wings are pen drawings made from the permanent mounts with the aid of the camera lucida or projection apparatus.

---

4. In a saturated solution of Potassium Oxalate.



## MATERIAL

*Nymphs*

About twenty species of the Membracidæ, representing eight genera of fairly wide distribution as regards relationship are common to the local fauna of Ithaca, New York, the nymphs of most of which are easily obtainable. These have been used for the determination of the nymphal tracheation. The choice of the various species studied has depended largely upon the characters of the adult wings. In cases of closely related forms where the venation was practically identical and no special problems were involved, the nymphs of a representative species only have been thoroughly worked out, except for the solution of certain questionable points. Some nymphs, also, owing to the form of the wing yield much better preparations than others, and these have been more elaborately figured where general characteristics only were being considered. Some have been discarded because of lack of positive identification and others because of the fact that they were less abundant and illustrated no features not found in forms more easily procured. The bulk of the work has been done from nymphs of the following genera: *Ceresa* (*bubalus*, *diceros* and *constans*), *Thelia* (*bimaculata*), *Telemona* (*ampelopsidis*), *Vanduzee* (*arquata*), *Campylenchia* (*curvata*) and *Enchenopa* (*binotata*). Altogether several thousand dissections have been made and each point in tracheation has been as carefully verified as possible. No attempt has been made to breed the insects since extensive field notes on the habitat, hosts, life-history and general biology of the local forms has made it possible to procure the nymphs at various stages without particular difficulty.

*Adults*

Besides the forms represented in the local fauna, the wings of all other species procurable have been studied with the view of obtaining a large number of types of venation. The writer is greatly indebted to the Entomological Department of Cornell for the privilege of examining the wings of all the species in the excellent collection of the University, which includes many forms that could not otherwise have been obtained. Thanks also are due to Dr. J. C. Bradley and to Mr. C. R. Plunket for the use of specimens from their collections.

Six subfamilies are recognized in the Membracidæ by the systematists in Hemiptera<sup>5</sup> and representative genera from all sub-families reported from the United States<sup>6</sup> have been examined. Wings from the following genera are figured in this paper as representative:

SMILIIDA	
	<i>Cerasini</i>
	Ceresa
	Stictocephala
	Acutalis
	Micrutalis
	<i>Telamonini</i>
	Carynota
	Thelia
	Glossonotus
	Telemona
	Telemonanthe
	Archasia
	Heliria
	<i>Smiliini</i>
	Smilia
	Cyrtolobus
	Cyrtolobus
	Atymna
	Xantholobus
	Ophiderma
	<i>Polyglyptini</i>
	Vanduzea
	Entylia
	Publilia
DARNIDA	Stictopelta
HOPLOPHORIDA	Platycotes
MEMBRACIDA	Campylenchia
	Enchenopa
	Tylopetta
	Philya
CENTRODITA	Centruchoides
	Platycentrus

(The above classification is based on that of E. P. VanDuzee in his "Studies in North American Membracidae," Bulletin of Buffalo Society Natural Science, 1908, Vol. IX.)

5. Cf. Stal, Hemiptera Africana IV, pp. 82-83.

Goding, Bibliographical and Synonymical Catalogue of the Described Membracidae of North America. Bull. Ill. State Lab. Nat. Hist., Vol. III, Art. XIV, p. 302.

VanDuzee, Bull. Buffalo Soc. Nat. Sci. 1908, Vol. IX, p. 31.

6. According to VanDuzee (Studies in North American Membracidae, p. 31) the Tragopida are not represented in this country. Moreover in this sub-family the fore wing at least is coriaceous and opaque externally, and would probably be of little value in the study of venation.

In addition to the species actually examined, careful comparison has been made with as many figured wings of the Membracidæ as could be located<sup>7</sup> and it has been a satisfaction to note that in practically all cases there is a constant and easily worked out agreement with the homologies as herein suggested.

Since the Membracidæ is principally an American family, only a few genera being found on the continent of Europe<sup>8</sup>, but two species in Britain<sup>9</sup> and very few reported from other parts of the world, there seems no reason to believe that our local forms in New York should not be typical of the family. Moreover, the venation is quite uniform throughout the family and it appears reasonable to suppose that the homologies as here worked out for the representative genera figured will be readily applicable to the entire Membracidæ.

#### NOMENCLATURE

Many of the specific, generic and sub-family distinctions in the Membracidæ are dependent upon the venation, and most tables and keys to the family follow the nomenclature of Fowler, Goding and others in which the characters of the cells are used as a basis of classification. Little attention has been paid to the veins except as to their number at the base of the wing or as forming the "petiole" of a cell.

The cells are called "areoles" or "areas" and are described as "marginal", "discoidal", "apical", "anterior", etc., and their bases as "petiolate", "truncate", etc., but little attempt has been made to identify the veins which limit these cells. Fowler in his discussion of the Ceresini in the *Biologia*<sup>10</sup> describes the "costal", "radial" and "ulnar" veins, and this nomenclature has been used to some extent by other writers.

The fore wing is commonly spoken of as the tegmina and its venation often designated as the elytral venation. The hind wing is referred to as the under wing or the second wing. The corium is often discussed separately, as is also the clavus

7. In the plates of Canon Fowler in the *Biologia Centrali Americana* particularly, the figures, while representing forms foreign to our fauna, are evidently very accurately reproduced and agree to a remarkable extent with our North American species, so far as venation is concerned.

8. Canon Fowler. *Bio. Cent. Amer., Insecta: Rhynchota, Homoptera.* Part II, p. 2.

9. *Cambridge Natural History, Insects Part II, p. 577.*

10. *Biologia Centrali Americana, Insecta: Rhynchota, Homoptera.* Part II, p. 87.

and the membranous margin, and altogether a rather complex and imposing accumulation of terms has been built up, not at all contradictory, but somewhat confusing.

It would be entirely unnecessary and out of place at this point to enter into the controversy regarding the systems of nomenclature of wing-veins and their respective merits, a subject which has been thoroughly and repeatedly reviewed<sup>11</sup>. The nomenclature used in this study is entirely that of the Comstock-Needham system, and therefore the veins and cells here described conform to those represented in other work done according to this system. The names "costa", "subcosta" "radius", "media", "cubitus" and "anal" will be used throughout. Thus the "terminal areole" of VanDuzee, the "third apical area" of Fowler and the "celule terminale" of Fairmaire becomes cell R<sup>5</sup> as dependent on the homology of the vein R<sup>5</sup>, and will be so designated in this discussion, and this same system will hold for all other veins and cells discussed.

#### THE MEMBRACID WING

The Membracidae is one of those families of the Homoptera in the wings of which the corium and clavus are usually membranous, the veins in most forms are distinct, there is practically no thickening at the base of the wing, and both pairs of wings are well developed (Fig. 1). These features are better shown in the membracid wings than in those of any of the other Hemiptera with the possible exception of the Cicadidae. The wings are well adapted for flying and the insects fly well for short distances with a whirring noise.

The fore wings are large, expanded and distinctly veined. They are usually membranous throughout, but occasionally show coriaceous patches and basal punctures, especially along the anterior margin. The clavus<sup>12</sup> is distinct, the claval suture

11. The historical discussion of the nomenclature of wing-veins is taken up in detail by Dr. A. D. MacGillivray in the "Wings of Tenthredinoidea," Proc. U. S. Museum, 1906, Vol. XXIX, pp. 570-574.

Miss Edith M. Patch reviews the terminology of homopterous wing venation in "Homologies of the Wing-Veins of the Aphididae, Psyllidae, Aleurodidae and Coccidae," *Annals Entomological Society of America*, 1909, Vol. 11, pp. 124-126.

Cf. also C. W. Woodworth, *The Wings of Insects*. University of California Publications, Agricultural Experiment Station Technical Bulletin, Entomology, Vol. 1, p. 142.

12. In the hemipterous wing the basal portion consists of two pieces. The term "clavus" is here applied to the narrow posterior piece which is next to the scutellum when the wing is closed. This is figured in Comstock's "Manual for the Study of Insects," p. 124.

occurring along the first anal vein. There are few cross-veins but those present are remarkably constant. The wing may or may not be covered by the pronotum, but in no case is it to be considered in the sense of an elytron.

The hind wing is not nearly so dissimilar to the fore wing as is the case in most insects. C. W. Woodworth in the "Wings of Insects"<sup>13</sup> remarks that "the hind wings of most of the families of Homoptera have more nearly kept pace with the front wings in their specialization, than have those of the Heteroptera". This is certainly true of the Membracidae. There are fewer veins and cells in the hind wing than in the fore but their homologies are evident.

Both wings are characterized by the strongly scalloped margin of the veined surface and the comparatively narrow terminal membrane.

Like most of the other Hemiptera, the wings of the Membracidae are specialized by reduction, but the reduction has not been carried so far as in most of the other families of this order. This reduction has been carried on in two ways, viz.: by atrophy and by coalescence. Reduction by atrophy is shown by costa in both wings. Coalescence, in turn, has been accomplished by two methods—by coalescence from the base towards the margin, as illustrated by cubitus, and by the anastomosis of veins in the center of the wing followed by their subsequent divergence, as shown in the case of radius four-plus-five plus media one-plus-two. No cases have been noted of coalescence from the margin proximad.

However, no hint of the particular veins in which this specialization occurs is given by the venation of the adult wing, and it is only by following the nymphal structure, trachea by trachea, and branch by branch, that the actual solution can be reached with any degree of accuracy.

#### NYMPHAL TRACHEATION

A study of the most general characteristics of the nymphal tracheation may well be made before proceeding to the consideration of the minutia. In the fore wing (Fig. 2), it will be noted that there are five main tracheæ. Beginning at the anterior margin, the first is unbranched and extends almost to the tip of the wing. The second appears two-branched and the posterior branch anastomoses for some distance with the ante-

13. Univ. of Cal. Publ., Ag. Ex. Sta. Tech. Bull. Ent., Vol. I, No. 1, p. 124.

rior branch of the following trachea. There is also a suggestion of splitting near the base of the anterior branch. The third is two-branched with the anastomosis as noted. The fourth is two-branched, the tracheæ separating very close to the base of the wing. The last is also two-branched with the branches coalescing at their extremities.

The relationship of these tracheæ with the corresponding wing veins is evident. Their identification as regards the homologies of wing veins in general is not so simple a matter. For this reason the veins as dependent on these tracheæ will be discussed in order, beginning at the costal margin.

#### FORE WING

##### *Costa*

Costa never appears as a separate vein in the adult wing. It was some time in the course of this study before sufficient data was obtained to determine exactly what had become of this vein, since most of the preparations failed to show a corresponding trachea in the nymphal wing. Finally however, an examination of younger stages of various species furnished the solution. In *Thelia bimaculata* (Fig. 3) it was found that costa was represented in the nymphal tracheation but never entered the wing for a sufficient distance to have a place in the adult structure. In most individuals the atrophy was greater than that shown in the figure. In *Telemona ampelopsidis* (Fig. 4) the trachea is twisted around the subcosta and no doubt coalesces with it in the vein which afterwards encloses them. In *Ceresa borealis* (Fig. 5) the trachea extends farther into the wing but is not so well developed and probably has no effect on the venation. In *Vanduzeeia arquata* (Fig. 6) much the same appearance is shown except that the trachea is stronger and lies nearer the margin of the wing.

To sum up then, the trachea which usually precedes the costal vein is represented in the nymphal structure but the vein itself is not found in the adult wing. In such genera as *Thelia*, *Acutalis* and *Glossonotus*<sup>14</sup> in which a slight membrane is found cephalad of subcosta but no thickened ridge is present, the vein is probably atrophied<sup>15</sup>.

14. All forms mentioned are figured either through the text or at the end of the discussion. The figures of adult wings are drawn to show the coalescence of tracheæ to form a single vein when such has been the case.

15. This is no unusual condition with costa. Comstock and Needham say (Wings of Insects, p. 858). "Its (costa's) trachea is often atrophied, probably owing to the disadvantageous position of its base in relation to air supply, as we have hitherto indicated."

In *Ceresa*, *Micrutalis*, *Telemona*, etc., in which subcosta forms the cephalic margin, the tracheæ for costa and subcosta have coalesced. In *Heliria*, *Vanduzea* and *Enchenopa* the trachea has had an influence on the costal margin to form a thickening near the base of the wing.

### Subcosta

Subcosta is constant in character throughout the family. It is strong, straight and unbranched and extends the full length of the wing (Fig. 2). It is the anterior vein of the wing, owing to the atrophy of costa, and as such often forms the cephalic margin. In the sub-families Hoplophorida and Membracida<sup>16</sup> the vein is usually contiguous to the anterior margin for its basal half, and then drops down, leaving a terminal membrane anterior to its distal half. Sometimes this membrane occurs down the entire cephalic margin. No splitting occurs at the end of the vein. It sometimes anastomoses with parts of radius as will be shown in the discussion of that vein, but this is due to the peculiarities of radius and to no irregularities on the part of subcosta. Its base occasionally shows a fullness or slack which later straightens out in the vein formation (Fig. 7). Altogether, subcosta is always permanent, straight, clean-cut and independent, both in its tracheation and in its final structure.

### Radius

The behavior of radius offered one of the most difficult problems of the membracid wing. Instead of the typical five-branched condition (Fig. 8) we have in the venation of this family (Fig. 2) what is seemingly a two-branched condition, with what appears to be a cross-vein connecting the cephalic branch with subcosta. This, in itself, would offer but little difficulty, since if the reduction of the five-branched type were carried far enough by coalescence outward, it would give a two-branched result. The natural method of reduction of radius is by the coalescence of the branches of each half of the radial sector, leaving the sector two-branched and the vein as a whole three-branched. If the same method of reduction be carried further,  $R_1$  and the sector only are left, giving a two-branched condition of the whole vein.

16. See figures of Platycotes, Phyllia, Campylenchia and Enchenopa. Nos. 51, 52 and 53.

But in the Membracidae several points not compatible with this natural method of reduction presented difficulties. In the first place, both branches showed constant and unmistakable signs of further subdivision at their tips, which would not be likely to be true of the cephalic branch if it were  $R_1$ . Moreover, the vein between the cephalic branch and subcosta was often seen to be preceded by a trachea. Again and again in mounts of different species this area contained a trachea which was evidently a branch from the cephalic branch of radius. If this were true, this most anterior branch should be  $R_1$ . But  $R_1$  normally leaves the main stem proximad of the division of the radial sector, while this branch seemingly pulls off from one half of the sector itself, and this demanded an explanation which was not immediately forthcoming.

The solution was first found in the wings of *Vanduzee* *arquata* and later this peculiar condition (Fig. 9) was verified in other genera. The trachea representing  $R_1$ , as will be seen from the figure, is weak and apparently greatly reduced. It leaves the main stem in the normal position, but runs in close juxtaposition to the radial sector beyond the point at which the latter branches. Here it turns cephalad and runs across to subcosta where it again turns outward and closely parallels subcosta for some distance in its course toward the tip of the wing. The sharp turns made by the trachea in following this course (Fig. 10) are remarkable, and in the veins which enclose this region of the wing, the bridge from radial sector to subcosta (Fig. 11) gives every appearance of a cross-vein.

While this interesting behavior of  $R_1$  is unusual, and perhaps peculiar to the Membracidae, it only illustrates another of the vagaries of which radius is capable. In fact, throughout the Hemiptera, radius seems to be most unreliable, and  $R_1$  capable of the most peculiar performances, being, according to Miss Patch<sup>17</sup> "the least stable of the hemipterous wing veins". It has been shown in the Cicadidae<sup>18</sup> that  $R_1$  has been crowded by subcosta until its trachea coalesces for its entire length with radial sector and its anterior branch. In the Pentatomidae<sup>19</sup> also, it has been supplanted by subcosta and is entirely

17. Annals of the Entomological Society of America, 1909, Vol. 2, p. 119.

18. Wings of Insects, p. 245.

19. Wings of Insects, p. 250.



atrophied. In the Coreidae<sup>20</sup>  $R_1$  is wanting. The weakness of the vein has been remarked in the Aphididae<sup>21</sup> and it is entirely lacking in the Psyllidae<sup>22</sup> and in the Aleurodidæ<sup>23</sup>. In fact, Comstock and Needham state<sup>24</sup> that the complete absence of the vein  $R_1$  is one of the most characteristic features in the venation of the wings of the Hemiptera.

It is of some phylogenetic interest, then, to note that in the Membracidae, while the vein is abnormal, it is *not* completely absent, and in this respect the membracid wings may be considered the most generalized of any of the families of Homoptera, at least those of which the homologies of wing-veins have been determined.

Most of the genera of the Membracidae show the position of  $R_1$  as described. In many it has been impossible to find the trachea, although the vein is present and constant. Since, however, the history of the vein is evidently traceable to the trachea representing  $R_1$ , it seems necessary to call this vein  $R_1$  whenever it appears.

In a few genera, namely, *Acutalis*, *Tylopelta*, *Enchenopa*, *Campylenchia*, *Platycentrus*, and *Centruchoides*, the vein comes off in its normal position. In the nymphal wings of *Enchenopa binotata*, for example (Fig. 12), the trachea is found in its natural place. These genera are, of course, still more generalized with regard to this special point, but are not so typical of the family.

The course of the rest of radius is evident from the tracheation. At its base it often anastomoses for some distance with media before these two principal veins separate for their respective courses through the wing. In *Ceresa*, *Stictocephala*, etc., this coalescence must be fairly constant, since it has been made a basis for classification<sup>25</sup>.  $R_{2+3}$  usually extends undivided to the tip of the wing. It is generally connected with  $R_{4+5}$  by a cross-vein.  $R_{4+5}$  is represented as one vein and coalesces with the anterior branch of media ( $M_{1+2}$ ) for a more or less extended part of its course. The amount of coalescence

20. Wings of Insects, p. 252.

21. Annals of the Entomological Society of America, 1909, Vol. II, p. 111.

22. Annals Ent. Soc. of Amer., 1909, Vol. II, p. 119.

23. Annals Ent. Soc. of Amer., 1909, Vol. II, p. 122.

24. Wings of Insects, p. 245.

25. Biologia Centrali Americana, Insecta: Rhynchota, Homoptera, Part II, p. 87.

shown in figure 11 is about the average. In a few species<sup>26</sup> the course is more extended, and in some<sup>27</sup> the veins do not coalesce at all but run some distance apart, connected by one or more cross-veins. Just before reaching the tip of the wing, however, this vein separates from media to make the apical or terminal cell, which is thus cell  $R_5$ . The tips of both branches of radial sector show signs of splitting in their tracheal condition. In some cases they actually remain separate and form additional cells in the wing. This is true of the species *Telemonanthe pulchella*, *Cyrtolobus vau* and *Smilia camelus* (see figures Nos. 39, 43 and 42). In the first,  $R_2$  and  $R_3$  are separate. In the second, a very small cell  $R_4$  appears, showing that  $R_4$  and  $R_5$  have not entirely coalesced.

In this species also, a peculiar condition of  $R_3$  is shown, the end of the vein still persisting at the margin of the wing, while its base has disappeared. In *Smilia camelus*,  $R_3$  has not entirely coalesced with  $R_2$ , and extends into the cell  $R_{2+3}$  where it is perhaps atrophying back toward its base. This means that in these forms the reduction has not proceeded so far as it has in the majority of the species.

Summing up, then, radius is typically three-branched in the Membracidae.  $R_1$  extends from  $R_{2+3}$  to subcosta.  $R_{2+3}$  and  $R_{4+5}$  usually extend as undivided branches, with the exceptions noted, to the tip of the wing,  $R_{4+5}$  ordinarily anastomosing for a variable part of its length with  $M_{1+2}$ .

### Media

The course of media (Fig. 13) is quite constant. Starting from the base of the wing in close proximity if not in actual contact with radius, it follows a relatively straight course for about two-thirds of the wing length. It represents the most posterior vein of the costa-subcosta-radius-media group, and its origin is intimately connected with the stem of these veins (Fig. 14). In such forms as *Acutalis*, *Micrutalis*, *Thelia*, and *Carynota* of the Smiliida, this close connection is not shown in the adult wing. In others, as *Ceresa* and *Stictocephala*, the relationship is striking, as has been referred to in the consideration of radius.

26. e. g., *Cyrtolobus vau* and *Atyma castaneae*.

27. *Platycolis sagittata*, *Enchenopa binotata*, *Campylenchia curvata*, *Centruchoides perdita*, and *Platycentrus acuticornis*.

In the distal third of the wing, media branches into  $M_{1+2}$  and  $M_{3+4}$ , the upper branch usually but not always uniting with  $R_{4+5}$ . This is, in most cases, the end of its branching, since the reduction by coalescence outward has obliterated the individual veins  $M_1$ ,  $M_2$ ,  $M_3$  and  $M_4$ . In a few cases these veins persist to the point of forming an extra marginal cell. This is true of *Archasia belfragei* and *Ophiderma pubescens*, where  $M_3$  and  $M_4$  are separate, and in *Micrutalis dorsalis* where  $M_1$  and  $M_2$  show a very slight space between them. In the latter species this feature, which has been remarked by VanDuzee in a taxonomic sense<sup>28</sup>, is not always constant. In *Smilia camelus*,  $M_4$  has behaved much as has  $R_2$  in the same species (see radius) by extending part way into cell  $M_{3+4}$  and probably atrophying toward its base. A peculiar condition is shown in *Xantholobus trilineatus* in which  $M_1$  and  $M_2$  have not coalesced, thus leaving a cell  $M_1$ .  $M_3$  has coalesced with  $M_2$  near the margin of the wing to form the unusual combination  $M_{2+3}$ .  $M_4$  extends part way into cell  $M_{3+4}$  as was seen in the case of *Smilia*.

On the whole, media represents a simple, natural reduction and is one of the most constant veins in the membracid wing.

#### Cubitus

With the consideration of cubitus comes a perplexing problem in interpretation. There is no doubt as to the tracheation, which is constant throughout the family, but the homologies are not at once evident. From the posterior base of the wing, and separate from the costa-subcosta-radius-media group, come two distinct main stems (Figs. 5 and 15). These must represent cubitus and the anals. The upper stem is typically two-branched which is characteristic of cubitus; the lower is three-branched and seems naturally to be First, Second and Third Anal respectively (Fig. 16). Certain features, however, make this interpretation unacceptable. The first and most important of these is the fact that the point of branching of the anterior trachea occurs so far back in the nymphal wing that it would not appear, and does not appear, in the adult venation. This is entirely inconsistent with the reduction which has taken place in all of the other veins of the same wing, and it is inconceivable that while coalescence outward has been taking place

28. Studies in North American Membracidae, p. 52.

in all the rest of the wing, cubitus has been dividing in the opposite direction. Moreover, the end of the cephalic branch shows, as did radius and media, unmistakable evidence of a doubly tracheated condition (Fig. 17). At first this was considered as a mere splitting of the end of the trachea and was disregarded. It appeared so constantly, however, and at times extended so far back into the wing, that it refused to be ignored. Again, it has been shown in other families of the Homoptera, that the first and second anal veins may be widely separated<sup>29</sup>, the first anal arising from the cubital stem. In view of these facts then, it appears that the most anterior branch of the upper vein represents both  $Cu_1$  and  $Cu_2$ . That these veins have coalesced outward in the regular manner, forming one vein only in the adult wing, although the two tracheæ are distinguishable in the nymphal condition. This interpretation makes the position of the anal fold in the membracid wing agree with the position which it assumes in the other Hemiptera, namely, along the first anal vein. If the next vein (First Anal) were considered as  $Cu_2$  it would make the Membracidæ peculiar in this respect, and not in keeping with the conditions in the closely related families.

The trachea runs parallel with media for about half the length of the wing and then makes an abrupt turn downward, running to the posterior margin. At this point it divides, the two branches however never separating but turning together outward again toward the tip. The vein which encloses them follows this course without deviation. Just after the vein makes the sharp turn caudad, a strong cross-vein connects it with  $M_{3+4}$ . This cross-vein (medio-cubital), as will be shown later, may be of varying length but is constant and very characteristic of the family. It well represents one of the points which brings out the importance of the study of tracheation. In the adult wing (Fig. 1) it might well be taken for a branch of cubitus, but the nymphal wing (Fig. 18) clearly shows that it is not preceded by a trachea. A careful search has been made through hundreds of mounts to establish this point, and no case has yet been found where this condition was not true. On the theory that the principal veins are preceded by trachea while the cross-veins are not, this would prove that the vein in question could not be a part of cubitus.

---

29. Wings of Insects, p. 249.

*The Anal Veins*

If the interpretation of the preceding structures has been correct, the remaining veins of the wing must represent the anals. As a matter of fact, this works out very simply and leaves little doubt regarding the homologies of the anal region. It is true that the third anal often shows a forking in the nymphal tracheation (Figs. 5 and 16), but this is of no particular consequence since in a very large number of wings, of which that of the cockroach may serve as an example<sup>30</sup>, the anal region has become filled with many veins branching from or posterior to the third anal. In fact, this condition (Fig. 19) homologizes perfectly with the tracheation of this vein in the *Cicadidæ*<sup>31</sup> which family is as close to the *Membracidæ* as any whose venation has been determined, and in which, as in the *Membracidæ*, the specialization has been by reduction. A more significant fact is that this condition is by no means a constant one and should not be considered as typical of the family. In the large majority of cases the anal tracheation is best represented by that shown in Figure 2.

According to this determination, then, the first anal vein arises from the base of cubitus with which stem it has been brought from the main trunk. If this is true, the first anal is very intimately connected with the cubital vein — so intimate, in fact, that it seems almost a misnomer to call it an anal with reference to the *Membracidæ* — but that it is an anal is shown by the fact that it homologizes with the first anal in the wings of other insects. It represents the claval suture in the fore wing and is in many forms very indistinct in appearance, and the wing is weak along the line which it follows. It is straight and unbranched throughout its course and is connected with no cross-veins. At its tip it unites with cubitus, and the two coalesce to form the marginal limiting vein of the cell  $M_4$ . This limiting vein, it must be remarked, is here preceded by three tracheæ, viz.  $Cu_1$ ,  $Cu_2$  and 1st anal.

Second anal and third anal enter the wing together by a different stem, posterior to that of the cubitus-first anal. They separate at once, forming a large and clearly defined cell, only to coalesce again after about one-third of their course has been

30. Wings of Insects, p. 773.

31. Wings of Insects, p. 249.

traversed (Fig. 20). In this condition they join first anal just before that vein unites with cubitus at its distal end.

This represents the normal procedure. It is not strange to find, however, in a reduced wing, that this region is subject to more variation than that of any of the other veins. In some species, for example, third anal never appears in the adult wing and the cell 2nd A is absent. This has been brought about either by the atrophy of third anal or by its coalescence for an entire instead of a partial length with second anal, the latter explanation being perhaps the more reasonable. Since this condition is found principally in the wings of the smaller species such as *Microtalis calva*, *Stictocephala lutea*, and *Cyrtolobus vau* (see figures 33, 31, 43) it is probably due to the lack of development of this part of the wing, which causes a crowding of the tracheæ cephalad. In other forms third anal breaks away from second anal after anastomosing for some distance, and sends a very short portion out through the membrane to the margin of the wing. This is found mainly in the larger wings, where there is more surface to be supported, being best seen in the fore wings of *Thelia bimaculata*, *Telemona ampelopsidis*, and *Platycotis sagittata*.

#### Cross-veins

Of the cross-veins which appear in the fore wing, three only are constant and characteristic of the family, the others being peculiar to certain genera and species and of little comparative importance.

The first of these characteristic cross-veins is found connecting  $R_{2+3}$  with  $R_{4+5}$ , dividing the cell  $R_3$  at about one-third its length from the point of branching of radial sector. It is fairly constant, but it does not appear in the genera *Acutalis* or *Microtalis* in so far as representatives of these genera have been studied. In the figured wing of *Ophiderma pubescens* q. v., this cross-vein is forked, a condition which is of course abnormal.

The second is equally constant but surprisingly variable in position. It appears between media and cubitus, usually in the basal third of the wing, but often shifts from a position close to the base of these veins (cf. *Ceresa diceros*) to one so far toward the tip of the wing that in the case of *Smilia camelus* (see figure) it has actually moved off of cubitus and its posterior end rests on the other cross-vein which connects Cu with  $M_{3+4}$ .

Thus it is the most unreliable cross-vein so far as position is concerned, which is found in the wing. In a few species it does not appear. In *Archasia belfragei*, media and cubitus dip toward and touch one another at the point where this vein is typically found. In *Entylia bactriana*, which is an interesting wing in other respects also, media and cubitus anastomose for such a distance as to make this vein unnecessary. The same is true of *Publilia concava*. In certain forms this vein varies within a species. The figures shown of *Thelia bimaculata* and *Carynota mera* show two cross-veins at this point, but this is only occasionally found even in those species.

The third constant cross-vein is that connecting  $M_{3+4}$  with Cu. It varies in length from a mere attachment, as in *Entylia bactriana*, to the prominent and important position which it assumes in most of the wings of the family. No membracid wing has been examined in the course of this study which did not show this cross-vein, and as has been suggested in the consideration of cubitus, it has been particularly noted as being an apparent part of that vein.

Other cross-veins are found, but with no regularity and of no especial significance.  $R_{4+5}$  occasionally does not unite with  $M_{1+2}$  and a cross-vein bridges over (e. g. *Platycotis sagittata*).  $M_{3+4}$  sometime moves so far from  $M_{1+2}$  that this part of the wing has been strengthened in the same manner and one species at least has added cross-veins to such an extent that the actual condition of the typical form is only conjectural from the material at hand. This species is *Phylia ferruginosa*, the species possessing the most unusual cross-veining of any Membracid studied.

#### *The tracheation of the wing-base*

In their basal structure the wings of the Membracidae refuse to agree exactly in structure with those of closely related families, and if the determination of homologies in this study is correct, they more nearly approach the hypothetical type than do any of the other Hemiptera.

It has been shown in the wing of the Cicada<sup>32</sup> that all the tracheae in the wing arise from one main trunk<sup>33</sup>. In the closely related family of Membracidae it would naturally be

32. Wings of Insects, pp. 243-249.

33. Wings of Insects, p. 244, Fig. 14 and the accompanying discussion.

supposed that this important feature would also hold true, but this appears not to be the case. Instead, the tracheæ arise from two main trunks, the most anterior of which gives rise to costa, subcosta, radius and media, while the other furnishes the origin of cubitus and the anals.

The two trunks come from the thorax at different angles, and so far as has been observed, are never united (Fig. 21). This does not prove, to be sure, that the connection never occurs, but it would seem that in the study of a very large number of nymphal wings the connection would sometimes have appeared if it were present. On the contrary, the study of a long series of wings of many genera and species seems to show that in this particular family the original hypothetical type of two main trunks has been preserved and that in this respect at least, the Membracidæ can be said to be the most generalized of the Hemiptera, being more conservative in this particular than even the Cicada.<sup>34</sup>

#### *Marginal Veins*

The scalloped appearance given to the venation by the marginal vein inside the membrane, is characteristic. The extremities of the longitudinal veins are connected by strong regular veins which form a smooth edge for the veined portion of the wing (Fig. 1). The origin of this structure is explained by the manner in which the ends of the longitudinal tracheæ branch and overlap when they reach the region under consideration (Fig. 22). Since the reduction of the wing has left at the tip branches of radius two-plus-three, radius four-plus-five, media one-plus-two, media three-plus-four and cubitus one-plus-two which have not entirely coalesced, it is natural that these tracheæ, which have probably in the wing of past times represented separate veins, should remain more or less distinct. This has happened, and the wing tip shows that these tracheæ tend to pull apart and run along the marginal lines (Fig. 23). It seems rather remarkable that any of these tracheæ should ever actually turn backward, but such is the case. The normal method is as follows: subcosta continues along the cephalic margin to the extreme tip of the wing;  $R_1$  unites with subcosta

34. Comstock and Needham state, "The conservative Hemiptera that retain most perfectly the fashions of ancient times so far at least as concerns the venation of the wings, are the cicadas."—*Wings of Insects*, p. 243.



from the point of its coalescence outward;  $R_2$  turns upward to meet  $Sc$  plus  $R_1$ ;  $R_3$  turns outward and downward and coalesces with the tip of  $R_4$ ;  $R_4$  turns upward to unite with  $R_3$ ;  $R_5$  continues outward to touch the end of  $M_1$ ;  $M_1$  bends upward to  $R_5$ ;  $M_2$  turns backward to unite with the tip of  $M_3$ ;  $M_3$  continues forward to meet  $M_2$ ;  $M_4$  also turns backward to meet the tracheæ of  $Cu_{1+2}$  and 1st A which have continued outward, and the tips of the other tracheæ have proceeded distad in their natural position, extending to points which enable them to coalesce with the tracheæ ahead.

In this way a strong marginal vein has been formed along the lines laid down by these tracheæ which is as strong and sometimes stronger than the longitudinal veins themselves, since it contains at various places in its course, the tips of two, three, and sometimes even four tracheæ.

#### Variation

This study would be incomplete if some mention were not made, in the consideration of the fore wing, of the variations which often occur. The venation which has been outlined has been in the main that of the normal structure. Considerable variation occurs, however, often within a species, and this deserves some mention.

The wing of *Thelia bimaculata* has been chosen as an illustration because this species shows perhaps the greatest range of variation found in any one species. In the diagram shown (Fig. 24) the dotted lines represent the maximum variation, and all stages between the normal and this maximum may be found. It will be noted that  $R_1$  sometimes leaves radius two-plus-three at a point very close to the fork of radial sector. This would represent a less specialized condition than the normal.  $R_{4+5}$  and  $M_{1+2}$  sometimes approach each other with a wide curve and barely touch, instead of coalescing in the usual manner, and this does away with the sharp bend of  $M_{1+2}$ .  $M_3$  and  $M_4$  are occasionally separate, forming an additional cell  $M_3$ . As might be supposed from the discussion of the cross-veins, that one between media and cubitus shows the greatest irregularities. It ranges from the most proximal position shown by the dotted lines at the left, to one very close to the point at which media branches, and in some cases even disappears altogether, media and cubitus bending toward and touching each other.

Such variation as this is not uncommon in the Membracidæ. For this reason it would seem that taxonomic characters based on the shape, size and number of cells should not be attached with the greatest importance unless it can be clearly proven that these irregularities do not occur in the forms in question.

It may be mentioned in passing, that *Thelia bimaculata* shows also a great variation in the length of the pronotal horn. An attempt has been made to compare this variation with that of the wing but the results were negative, and the variation of the two structures seems to be entirely independent.

#### THE HIND WING

As has been stated (p. 81) the hind wing in the Membracidæ has more nearly kept pace with the fore wing in specialization than is usually the case in Hemiptera. An interpretation, therefore, of the fore wing leaves little to be determined so far as homologies are concerned and in fact the venation, after the tracheation has been worked out, is almost self-evident. In the hind wing the reduction has gone further than in the fore wing as is shown in the nymphal tracheation (Fig. 25). The tracheæ for costa and subcosta have disappeared. The wing, however, shows a thickening or ridge along the cephalic margin which is probably due to subcosta or perhaps in some cases to costa-plus-subcosta, although the preceding tracheæ are not distinguishable and the vein itself not prominent. Radius behaves much as in the fore wing. The trachea is apparently two-branched but high magnification shows that  $R_1$  is present, running close to  $R_{2+3}$  (Fig. 26). Occasionally also,  $R_1$  upon reaching the margin of the wing turns backward to meet the costal thickening so that in some cases the point at which costa-plus-subcosta unites with  $R_{2+3}$  represents what remains of  $R_1$  (Fig. 27). The most important point of difference between the two wings is found in the cross vein r-m connecting  $R_{4+5}$  with  $M_{1+2}$ . This difference has been noted by Redtenbacher in his explanation of the hind wing of *Centrotus cornutus*<sup>35</sup> the only Membracid which he figures and which happens to show this character. In the fore wing these longitudinal veins ( $R_{4+5}$  and  $M_{1+2}$ ) usually anastomose. In the hind wing

35. Redtenbacher, Josef. Vergleichende Studien über das Flügelgeäder der Insecten, Ann. k. k. Naturh. Hofmus. I, 1886, p. 187.

they are often some distance apart and connected by a strong cross-vein.<sup>36</sup> The explanation to the disappearance of costa and subcosta which causes this condition — which is of course the more generalized one — is probably that the median part of the wing, having an advantageous blood supply, has developed to such an extent as to crowd the cephalic region, causing radius to move over into that part of the wing usually occupied by costa and subcosta, and forcing these tracheæ out of existence.

Media is typical (Fig. 28), branching in about the center of the wing into  $M_{1+2}$  and  $M_{3+4}$  which continue their respective courses toward the tip, there to turn along the marginal line as in the fore wing.

Cubitus likewise presents the same condition that it does in the fore wing (Fig. 29). At times the tracheæ representing  $Cu_1$  and  $Cu_2$  respectively may be traced side by side for some distance back into the wing, but in no case do they separate.

First anal differs from the front wing in being stronger and not paralleling the suture. The wing membrane at this point in the hind wing is smooth and firm.

Second and third anals are usually coalesced to form one vein in the adult hind wing, although the individual tracheæ are to be seen in the nymphal structure. Occasionally these two veins separate to form the cell 2nd A as in *Ceresa bubalus*.

This is the normal venation. Some slight modifications can be found in a few genera. In *Smilia*, *Cyrtolobus*, *Xantholobus*, *Ophiderma*, and others, the characteristic cross-vein between  $R_{4+5}$  and  $M_{1+2}$  is lacking, these two veins anastomosing as in the front wing. In other respects the hind wings vary far less among the genera and species than in the fore wing, even in minor details. In many cases they are identical and it has been hard to find forms with differences marked enough to be worth figuring. It will be remarked in the figures that in shape and general appearance the agreement is quite noticeable.

36. See figures of *Carynota mera*, *Thelia bimaculata*, *Glossonotus crataegi*, *Telemona ampelopsidis*, *Archasia belfragei*, and *Heliria scalaria*.

## BIBLIOGRAPHY.

The paper which has been the principal basis for this study and which has been a source of constant inspiration throughout the work, is Comstock-Needham's "Wings of Insects," published in the American Naturalist, Vols. XXXII and XXXIII, 1898 and 1899. Other publications and texts used are the following:

- COMSTOCK. Manual for the Study of Insects.  
 STAL. Hemiptera Africana, Vol. IV.  
 GODING. Bibliographical and Synonymical Catalogue of the Described Membracidae of North America, Bulletin Illinois State Laboratory Natural History, Vol. 3, Art. XIV.  
 VANDUZEE. Studies in North American Membracidae, Bulletin Buffalo Society Natural Science, 1908, Vol. IX.  
 FOWLER. Biologia Centrali Americana, Insecta: Rhynchota, Homoptera Part II. Cambridge Natural History, Vol. VI, Insects, Part II.  
 MACGILLIVRAY. Wings of Tenthredinoidea, Proceedings U. S. Natural Museum, 1906, Vol. XXIX.  
 PATCH, MISS EDITH M. Homologies of the Wing Veins of the Aphididae, Psyllidae, Aleurodidae and Coccidae, Annals of the Entomological Society of America, 1909, Vol. II.  
 WOODWORTH. The Wing Veins of Insects, University of California Publications, Agricultural Experiment Station Technical Bulletin, Entomology, Vol. I, 1906.  
 REDTENBACHER. Vergleichende Studien über das Flügelgeäder der Insecten, Ann. k. k. Naturh. I, 1886.  
 HODGKISS. The Apple and Pear Membracids, Geneva Agricultural Station Technical Bulletin No. 17, 1910.  
 FAIRMAIRE. Revue de la tribu des Membracides, Ann. de la Soc. Ent. de France, 1846, Ser. II, Tome IV.  
 SCHMIDT. Beitrag zur Kenntnis der Membraciden. Stett. ent. Ztg., 1906, Vol. 67.

## FIGURES.

The figures of nymphal wings, and the diagrams used, are arbitrarily arranged in the order in which reference is made to them in the text, without respect to relationship of species.

The figures of adult wings are arranged according to subfamilies to facilitate reference. The order of subfamilies is based on Van Duzee's "Studies in North American Membracidae."

The following is the explanation of the figures in order:

*Nymphal wings and diagrams.*

- Fig. 1. Fore and hind wings of *Thelia bimaculata*.  
 Fig. 2. Fore wing nymph—*Thelia bimaculata*.  
 Fig. 3. Fore wing nymph—*Thelia bimaculata*, showing costa.  
 Fig. 4. Fore wing nymph—*Telemona ampelopsidis*, showing costa.  
 Fig. 5. Fore wing nymph—*Ceresa borealis*, showing costa.  
 Fig. 6. Fore wing nymph—*Vanduzeea arquata*, showing costa.  
 Fig. 7. Fore wing nymph—*Vanduzeea arquata*, showing base of costa.  
 Fig. 8. Diagram showing typical radius.  
 Fig. 9. Fore wing nymph—*Vanduzeea arquata*, showing  $R_1$ .  
 Fig. 10. Highly magnified portion of fore wing nymph of *Vanduzeea arquata*, showing region of  $R_1$ .  
 Fig. 11. Highly magnified portion of fore wing nymph of *Telemona ampelopsidis*, showing region of  $R_1$ .  
 Fig. 12. Fore wing nymph—*Enchenopa binotata*, showing  $R_1$ .  
 Fig. 13. Fore wing nymph—*Ceresa diceros*, showing media and the coalescence of  $R_{4+5}$  with  $M_{1+2}$ .

- Fig. 14. Base of fore wing nymph—*Ceresa diceros*, showing origin of media.  
 Fig. 15. Base of fore wing nymph—*Thelia bimaculata*.  
 Fig. 16. Fore wing nymph—*Ceresa bubalus*, showing anals.  
 Fig. 17. Fore wing nymph—*Ceresa diceros*, showing cubitus.  
 Fig. 18. Fore wing nymph—*Thelia bimaculata*, showing cross-vein.  
 Fig. 19. Fore wing nymph—*Telemona ampelopsidis*, showing anals.  
 Fig. 20. Fore wing nymph—*Vanduzea arquata*, showing 2nd and 3rd anals.  
 Fig. 21. Base of fore wing nymph—*Thelia bimaculata*, showing basal tracheation.  
 Fig. 22. Fore wing nymph—*Ceresa bubalus*, showing branches of longitudinal veins.  
 Fig. 23. Diagram of tracheation in tip of fore wing, showing formation of marginal vein.  
 Fig. 24. Diagram of variations in wing of *Thelia bimaculata*.  
 Fig. 25. Hind wing nymph—*Thelia bimaculata*.  
 Fig. 26. Highly magnified portion of hind wing nymph of *Thelia bimaculata* showing region of  $R_1$ .  
 Fig. 27. Diagram showing position of the remains of  $R_1$  in hind wing.  
 Fig. 28. Hind wing nymph—*Vanduzea arquata*, showing cubita.  
 Fig. 29. Hind wing nymph—*Ceresa diceros*, showing cubitus.

*Adult fore wings.*

- |  |  |
|--|--|
| Fig. 30. <i>Ceresa bubalus</i> .         | Fig. 44. <i>Atyma castaneae</i> .          |
| Fig. 31. <i>Stictocephala lutea</i> .    | Fig. 45. <i>Xanthlobus trilineatus</i> .   |
| Fig. 32. <i>Acutalis tartarea</i> .      | Fig. 46. <i>Ophiderma pubescens</i> .      |
| Fig. 33. <i>Micrutalis calva</i> .       | Fig. 47. <i>Vanduzea arquata</i> .         |
| Fig. 34. <i>Micrutalis dorsalis</i> .    | Fig. 48. <i>Entylia bactriana</i> .        |
| Fig. 35. <i>Carynota mera</i> .          | Fig. 49. <i>Publilia concava</i> .         |
| Fig. 36. <i>Thelia bimaculata</i> .      | Fig. 50. <i>Stictopelta marmorata</i> .    |
| Fig. 37. <i>Glossonotus crataegi</i> .   | Fig. 51. <i>Platycotis sagittata</i> .     |
| Fig. 38. <i>Telemona ampelopsidis</i> .  | Fig. 52. <i>Campylenchia curvata</i> .     |
| Fig. 39. <i>Telemonanthe pulchella</i> . | Fig. 53. <i>Enchenopa binotata</i> .       |
| Fig. 40. <i>Archasia belfragei</i> .     | Fig. 54. <i>Tylopelta gibberata</i> .      |
| Fig. 41. <i>Heliria scalari</i> .        | Fig. 55. <i>Phylia ferruginosa</i> .       |
| Fig. 42. <i>Smilia camelus</i> .         | Fig. 56. <i>Centruchoides perdita</i> .    |
| Fig. 43. <i>Cyrtolobus vau</i> .         | Fig. 57. <i>Platycentrus acuticornis</i> . |

*Adult hind wings.*

- |   |  |
|---|--|
| Fig. 58. <i>Ceresa bubalus</i> .        | Fig. 67. <i>Xanthlobus trilineatus</i> . |
| Fig. 59. <i>Carynota mera</i> .         | Fig. 68. <i>Ophiderma pubescens</i> .    |
| Fig. 60. <i>Thelia bimaculata</i> .     | Fig. 69. <i>Vanduzea arquata</i> .       |
| Fig. 61. <i>Glossonotus crataegi</i> .  | Fig. 70. <i>Stictopelta marmorata</i> .  |
| Fig. 62. <i>Telemona ampelopsidis</i> . | Fig. 71. <i>Platycotis sagittata</i> .   |
| Fig. 63. <i>Archasia belfragei</i> .    | Fig. 72. <i>Campylenchia curvata</i> .   |
| Fig. 64. <i>Heliria scalari</i> .       | Fig. 73. <i>Enchenopa binotata</i> .     |
| Fig. 65. <i>Smilia camelus</i> .        | Fig. 74. <i>Centruchoides perdita</i> .  |
| Fig. 66. <i>Cyrtolobus vau</i> .        |  |

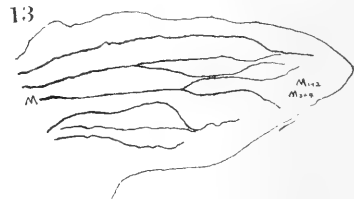
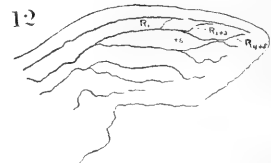
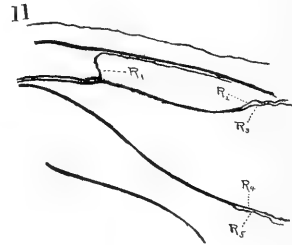
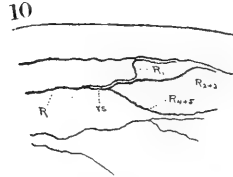
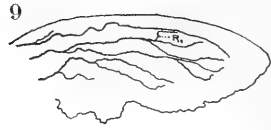
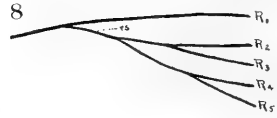
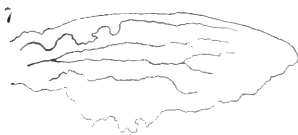
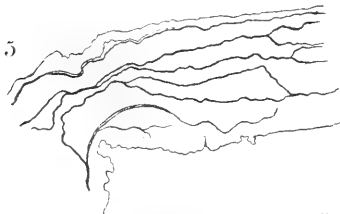
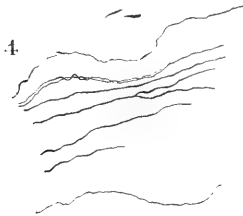
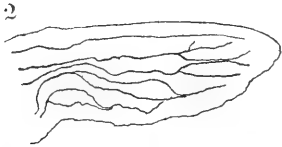
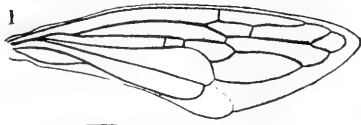

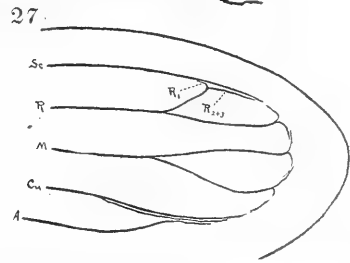
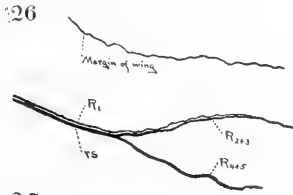
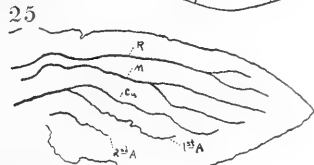
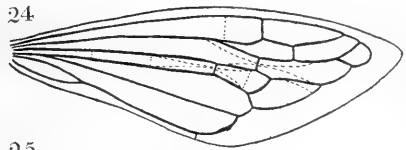
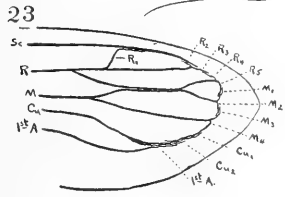
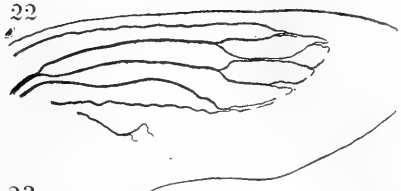
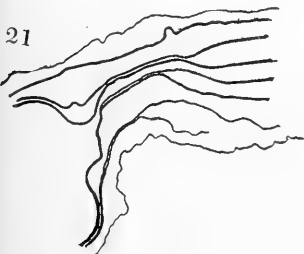
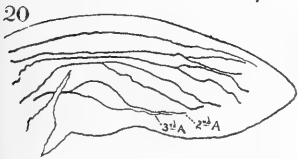
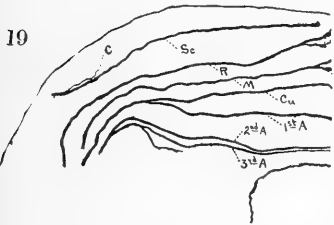
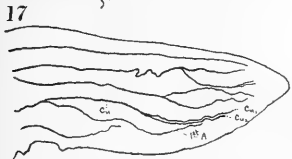
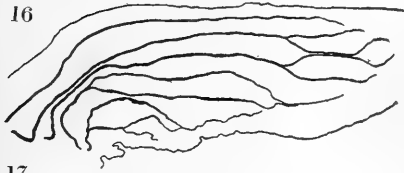
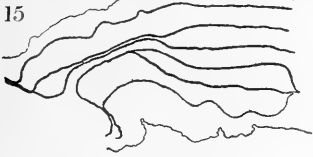

W. D. Funkhouser.

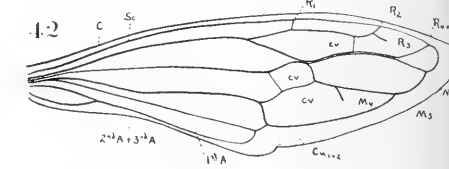
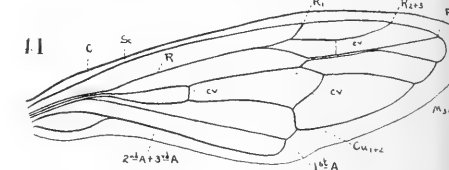
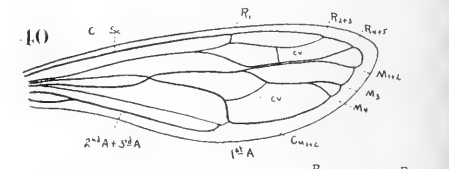
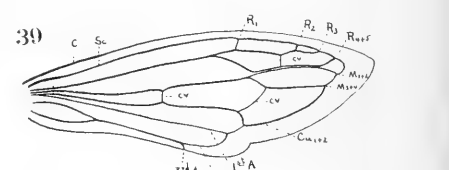
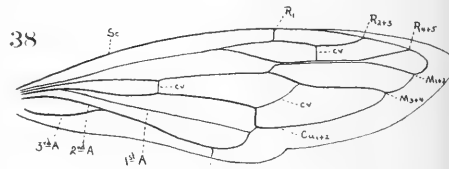
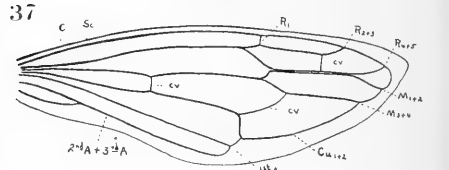
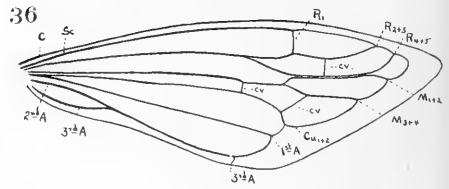
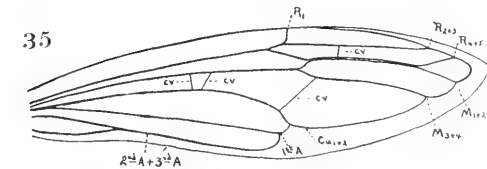
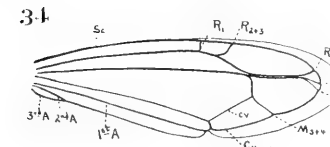
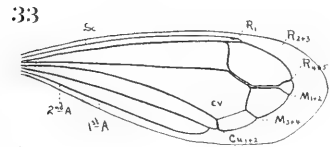
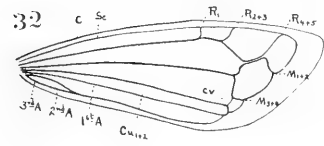
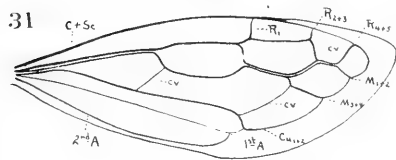
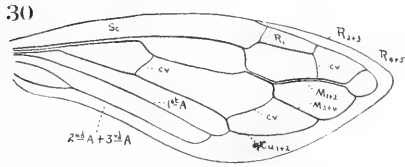
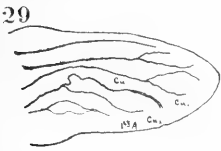



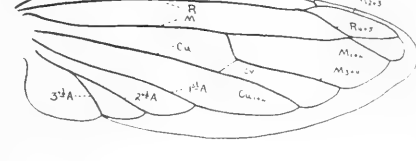
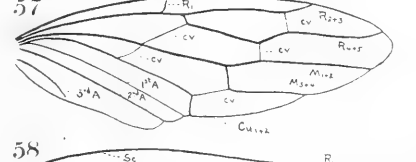
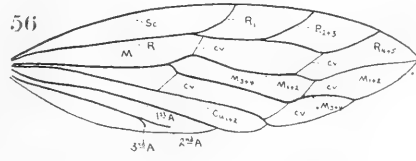
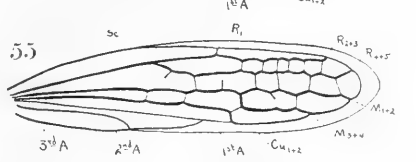
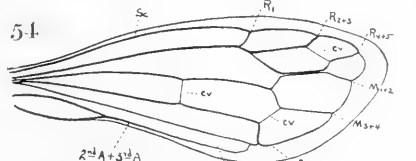
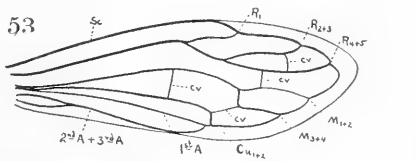
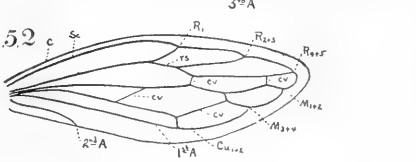
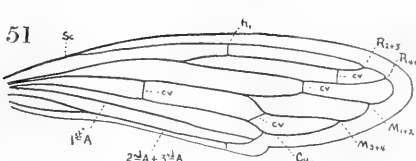
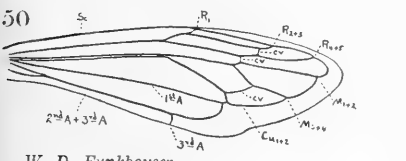
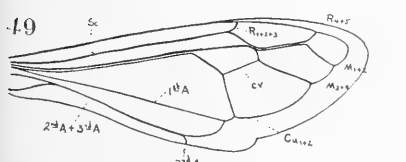
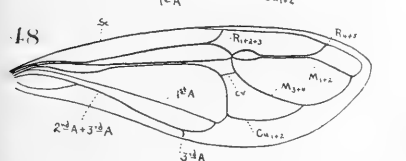
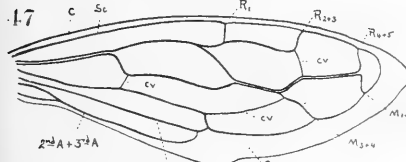
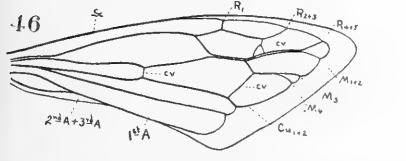
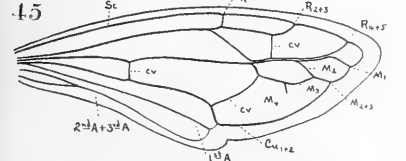
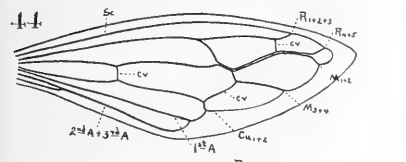
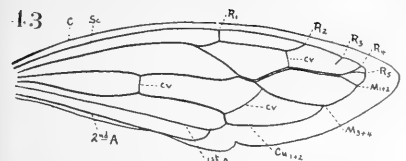

W. D. Funkhouser.

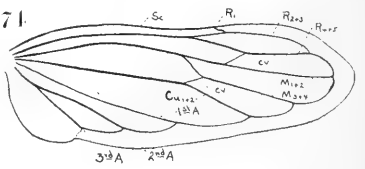
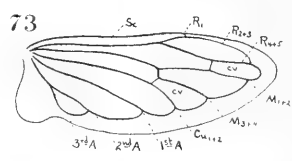
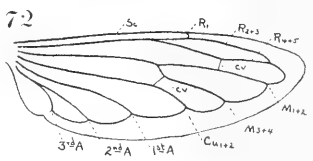
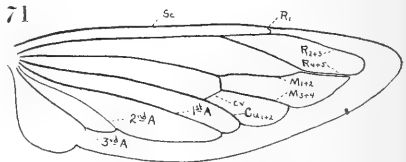
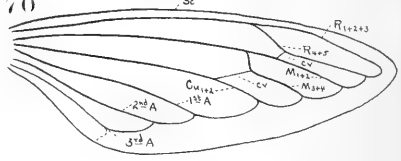
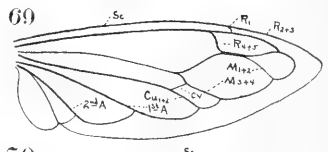
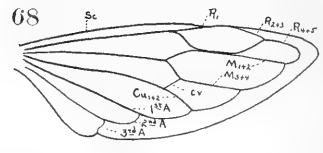
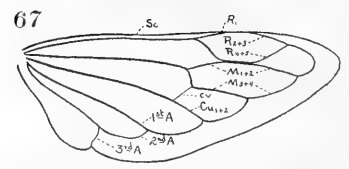
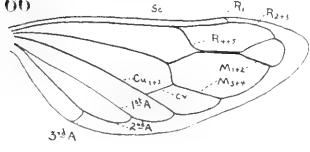
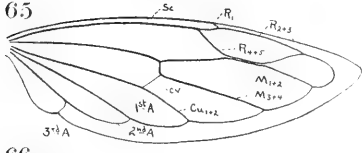
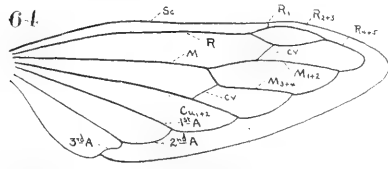
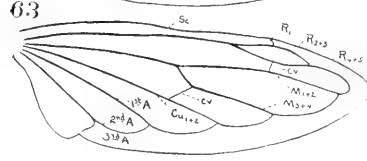
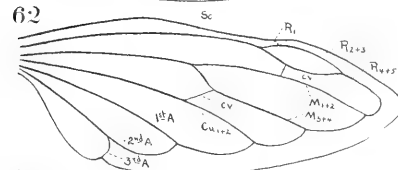
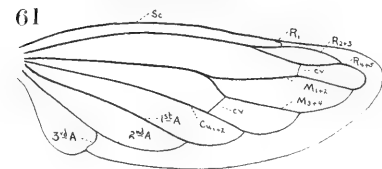
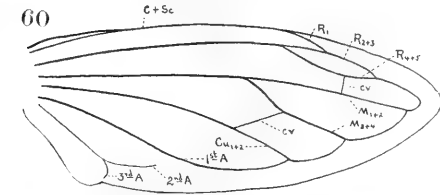
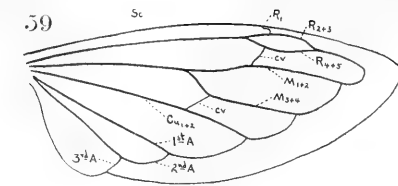

W. D. Funkhouser.

## THE WING VENATION OF THE JASSIDAE.

Z. P. METCALF.

The present paper was undertaken several years ago at the suggestion of Professor Herbert Osborn. At that time it was thought that the wing veins of Homopterous insects could be identified in the adult stage by carefully comparing them with the venation of the Cicadidæ as determined by Comstock and Needham '98-'99. This, however, was found to be impracticable as it was soon discovered that the wing veins of most of the Homoptera have been greatly reduced and much modified from the Cicadid type. The study was then discontinued until the spring of 1910, when it was resumed by studying it from the standpoint of the nymphal wing pads.

At first the wing pads were removed as carefully as possible and mounted in glycerine jelly, as recommended by Comstock and Needham '98-'99. Later on many wing pads were mounted in xylene damar as recommended by Miss Patch '09. It was soon discovered, however, that just as good results could be obtained by mounting the wing pads in water. These wing pads were then either photographed or drawn with the aid of the camera lucida. For most Jassidæ it was found more satisfactory to draw them with the camera lucida. This is due to the fact that the outer covering of the wing pad is very thick and frequently dark colored. In addition many of the wing pads were so thick that, using the high powers necessary, it was found to be impossible to bring all parts of all the tracheæ into sharp focus at the same time. This led to some confusion as many of the wing pads are provided with long spines which make the interpretation of the tracheæ difficult, as many of the spines are so placed as to appear in photographs as branches of the tracheæ which are slightly out of focus.

After the drawings were finished they were carefully compared many times over with wing pads from nymphs collected at later dates. If any marked differences were noted drawings were made and these again compared with the pads from nymphs collected at later dates. In this way, it is believed that all errors that might arise have been corrected or eliminated. The nymphal wing pads shown in the plates have been carefully selected from these drawings or redrawn from photographs.

The adult wings shown have been drawn with the aid of the Edinger drawing apparatus and have been selected, for the most part, from adults showing the normal venation. In a few cases, however, wings have been used which show the presence of unusual cross veins or the absence of usual cross veins.

In spite of the fact that many different methods of mounting were tried, several genera did not yield satisfactory mounts. The most conspicuous genera, in this respect, were *Kolla* and *Tettigoniella*. In spite of the fact that several hundred wing pads of these two genera were mounted from specimens collected from early spring to late summer, no satisfactory mounts were secured. Certain species in other genera show this same characteristic. Perhaps the most conspicuous species, in this respect, is *Diedrocephala versuta* Say. Nymphs of this species can be found in great numbers at Raleigh, North Carolina, throughout the season. Yet in spite of the fact that they were collected in large numbers and treated in many different ways no satisfactory wing pads of *Diedrocephala versuta* have been secured.

It is also necessary to secure the nymphs at the proper time. Some little time before the insect molts, the wing is very much crumpled in its sheath. This is especially true of the last molt. This is unfortunate as, in many cases, the older wing pads are necessary for determining the homologies of some of the tracheæ and veins. As already pointed out by Comstock and Needham '98-'99 the best results can be secured by selecting the paler colored individuals.

In all twenty-five genera of *Jassidæ* have been studied in the preparation of this paper. These genera represent such forms as could be readily secured in the vicinity of Raleigh, North Carolina. They contain representatives of all of the subfamilies and tribes of *Jassidæ* commonly found in Eastern North America.

In the course of this study many hundreds of nymphs have been collected and their wing pads studied. It has not always been found possible to remove the wing pads so as to secure the body tracheæ. The writer does not consider this important, however, as all of the pads have been removed close enough to the base to assure him of the homologies of the principal tracheæ.

This paper is founded upon the work of Comstock and Needham '98-'99. It adopts the same system they propose for naming the veins and for naming and numbering the cells, as the writer believes that this system is the only logical one that has been offered. An attempt made to homologize the veins of adult *Homoptera* and a subsequent study of the tracheation that precedes venation, has thoroughly convinced the writer that the Comstock-Needham system is the only logical one.

#### THE FORE WING.

The type of the fore wing of *Jassidæ* is fairly uniform but in order to point out the difference that exists the tracheæ will be considered in detail beginning at the costal margin.

The wings of *Jassidæ* show marked specialization by reduction. This reduction is usually accompanied by the atrophy of one of the branches of one of the main tracheæ and the shifting of a branch of a neighboring trachea until it occupies the region of the atrophied trachea. This is well illustrated in the atrophy of  $M_{1+2}$  of the fore wing which is discussed below. Another excellent example of the same thing is found in the *Typhlocybidæ* where  $M_{3+4}$  occupies the region usually traversed by  $Cu_1$ . The atrophy of these tracheæ with the subsequent shifting of other tracheæ which take their places gives to the wings of the *Jassidæ* their characteristic aspect.

#### THE COSTA OF FORE WING.

The costal trachea is absent in all of the Jassid wings that have been examined with the exception of *Gypona* (Fig. 8). Here the costal trachea is long being almost as long as subcosta and running parallel with it throughout its length. In no other Jassid was any trace of Costa found. In all cases the nymphal pad was removed as near the base as possible and the body trachea was examined for traces of the costal spur but no trace of such spur was found. This was due to the fact, perhaps, that it is impossible to get any great length of the body trachea in such a dissection. In a few cases, however, a considerable length of the body trachea was secured (Figs. 3, 5, 62, 64). This indicates that Costa has practically disappeared from the *Jassidæ*.

## THE SUBCOSTA OF THE FORE WING.

The subcostal trachea in the *Jassidæ* is very anomalous. It reaches its greatest length, in the genera examined, in the genus *Jassus* (Fig. 60), where it passes beyond the apex of the wing and replaces  $R_2$  and  $R_3$  in the ambient vein. Subcosta is slightly shorter in *Gypona* (Fig. 8), of about the same length in *Spangbergiella* (Fig. 20), also in *Agallia* (Fig. 1). In *Acinopterus* (Fig. 41) it is still shorter barely reaching  $R_2$ . In *Platymetopius* (Fig. 26) it is about half the length of the main stem of Radius. No further evidence of the presence of Subcosta was found although the Subcostal vein on the border of the wing is well developed in all of the adult wings which the writer has examined and it shows very clearly as a distinctly lighter area in all the older nymphs examined. This series undoubtedly shows how the subcosta has atrophied in *Jassidæ*.

## THE RADIUS OF THE FORE WING

The radial trachea in the fore wing of *Jassidæ* is typically two-branched although in some forms three and even four branches do occur. The two branches of the typical radius represent  $R_{2+3}$  and  $R_{4+5}$ .  $R_1$  has almost completely disappeared from the fore wings of the *Jassidæ*. It does occur, as a delicate branch, in a few genera but gives rise to a very characteristic cross vein between subcosta and radius which is known currently as the "nodal vein". The nodal vein, however, is a very anomalous one and its characters will be discussed later.  $R_1$  has been found in the following widely separated genera, *Oncometopia* (Fig. 3), *Scaphoideus* (Fig. 44) and *Typhlocyba* (Fig. 64). In other genera there remains a distinct cross vein connecting subcosta with the main stem of radius, or subcosta with  $R_{2+3}$ . This vein, which is usually referred to as the nodal vein, undoubtedly represents the remnant of  $R_1$  or  $R_2$ . Or it may be considered as a vein which merely followed a weak lateral branch of  $R$  or  $R_{2+3}$ , which either happened to be connected with the main stem of radius, when it resembles  $R_1$ , or it may have happened to be connected with  $R_{2+3}$  in that case it resembles  $R_2$ . The writer is inclined to think that this is a distinct vein representing in some cases  $R_1$  and in others  $R_2$ .

Trachea  $R_1$  is very conspicuous in *Oncometopia* (Fig. 3), *Scaphoideus* (Fig. 44) and *Typhlocyba* (Fig. 64). The resulting

cross vein is attached to radius in some species of *Scaphoideus* (Fig. 53) and in *Typhlocyba* (Fig. 77), but in *Oncometopia* the resulting cross vein is sometimes absent in the adult wing, and is sometimes present as a fairly strong cross vein uniting with radius near the point where it branches into  $R_{2+3}$  and  $R_{4+5}$ . In other cases, it appears as a fairly strong cross vein distinctly uniting subcosta with  $R_{2+3}$ . The whole question seems to be settled by reference to figure 3 which was taken from a half grown nymph. This wing pad shows a weak  $R_1$  which runs parallel to  $R_{2+3}$  for a considerable distance and then bends toward the costal margin. All attempts to secure older nymphs whose wing pads would show the forming veins along the tracheæ failed owing to the thickness of the pads and the large amount of coloring matter. Inasmuch as trachea  $R_1$  does run parallel with  $R_{2+3}$  for some distance it would seem to indicate that the point of attachment of the cross vein which follows the trachea might be at any one of various points along the radial vein over a considerable length of that vein.

In other cases this cross vein is very evidently  $R_2$ . It appears as a weak lateral branch of  $R_{2+3}$  in *Parabolocratus* (Fig. 23), as a somewhat stronger branch in *Goniagnathus* (Fig. 25), as a still stronger branch in *Phlepsius* (Fig. 48). In *Acinopterus* (Fig. 41) the trachea gradually diverges but the forming vein is set at nearly a right angle to  $R_{2+3}$ . In *Jassus* (Fig. 60) trachea  $R_2$  reaches its greatest size for any of the genera examined and the vein in the adult wing seems to follow the course of the trachea rather closely. In *Chlorotettix* (Fig. 43) tracheæ  $R_2$  and  $R_3$  are united for nearly their entire length, being separated only at their tips. This character seems to be comparatively constant for the genus (Fig. 52). In still other genera the nodal cross vein is formed without being preceded by any trachea. This is especially conspicuous in certain species of *Draeculacephala* (Fig. 6) which have only one cross vein connecting subcosta with  $R_{2+3}$ . In *Eutettix* (Fig. 46) two cross veins are formed, one occupying the position of  $R_1$  and the other the position of  $R_2$ . Neither one of these cross veins is preceded by a trachea. There is an interesting question involved in the genus *Scaphoideus*. As pointed out by Osborn '00 the nodal vein arises from radius in *auronitens* and certain other species while in *jucundus* and allied species it arises from  $R_{2+3}$ . Unfortunately the writer was able to secure nymphs of

only the first group but he believes that the nodal cross vein in the  *jucundus*  group is the untracheated cross vein between  $R_1$  and  $R_3$  (Fig. 44). In this case the nodal cross vein in  *Scaphoideus*  would be  $R_1$  when the "nodal vein arises from discal cell" and  $R_2$  when the "nodal vein arises from anteapical cell".

In most of the genera of the  *Jassidæ*  radius branches once and only once, the resulting branches being  $R_{2+3}$  and  $R_{4+5}$  (Figs. 1, 5, 6, 20, 22, 26, 28, 62). In several cases referred to above  $R_2$  separates from  $R_3$ . In only one genus examined,  *Eutettix*  (Fig. 46) has  $R_4$  and  $R_5$  been found separated. In this case  $R_4$  occurs as a cross vein between  $R_{2+3}$  and  $R_5$ .  $R_{2+3}$  is much atrophied and  $R_4$  extends to the margin traversing the region usually occupied by  $R_{2+3}$ . In a single genus examined,  *Empoasca*  (Fig. 66), radius extends as a single unbranched trachea from the base of the wing pad to the apex. Although in the adult wing, in many cases, there is a cross vein connecting radius with the margin of the wing.

#### MEDIUS OF THE FORE WING.

Medius in the  *Jassidæ*  is typically two-branched. These branches embrace  $M_1$  and  $M_2$ , and  $M_3$  and  $M_4$  respectively.  $M_{1+2}$  is well developed in  *Chlorotettix*  (Fig. 43) where it runs parallel to  $R_{4+5}$ . It is not so well developed in  *Parabolocratus*  (Fig. 23)  *Platymetopius*  (Fig. 26) and  *Gypona*  (Fig. 8). In  *Deltocephalus*  (Fig. 28)  $M_{1+2}$  is reduced to a mere spur. In the other genera studied medius consists of a single unbranched trachea which extends from the base to the apex of the wing pad, although in most cases there is a strong transverse vein connecting medius with  $R_{4+5}$ . The writer believes that the above series, as outlined, represents fairly well the development of medius from a two-branched condition to a single unbranched trachea. If this conception be correct  $M_{1+2}$  must have come to lie parallel with  $R_{4+5}$  and has been gradually reduced until the present time it is at most merely a cross vein connecting medius with  $R_{4+5}$ . The vein having persisted in some cases notwithstanding the fact that the trachea has been lost. This is especially evident in  *Agallia*  (Fig. 1),  *Scaphoideus*  (Fig. 44) and  *Eutettix*  (Fig. 46).

In the  *Typhlocybidæ*  (Fig. 64 and 66) medius is very evidently two branched. In  *Typhlocyba*  (Fig. 64)  $R_{4+5}$  is greatly reduced



and resembles a cross vein. The usual position of  $R_{4+5}$  is occupied by  $M_{1+2}$ . In *Empoasca* (Fig. 66)  $R_s$  coalesces with  $M_{1+2}$  for a short distance and then diverges toward the costal border  $M_{3+4}$  being very distinct.

#### CUBITUS AND FIRST ANAL OF THE FORE WING.

In all of the genera of *Jassidæ* examined the cubital and first anal tracheæ were the most constant and formed one of the best landmarks in the study of the relations of the tracheæ. They are coalesced for some little distance from the base of the wing.

Cubitus is frequently two branched (Figs. 8, 22, 23, 25, 43, 48, 60). Here again we can trace almost a complete series from a form like *Jassus* (Fig. 60) or *Goniognathus* (Fig. 25), where  $Cu_2$  is equally as important as  $Cu_1$ , through intermediate forms like *Gypona* (Fig. 8), to forms like *Phlepsius* (Fig. 48) where  $Cu_2$  is reduced to a mere spur.

In the *Typhlocybidæ* (Fig. 64 and 66)  $M_{3+4}$  has come to occupy the region usually occupied by  $Cu_1$  and cubitus is unbranched and diverges strongly toward the anal border which gives it the appearance of having lost branch  $Cu_1$  and having retained  $Cu_2$ .

The first anal vein lies along the anal border of the claval suture. It has not been usually recognized as a distinct vein owing to the fact that as a vein it is rather inconspicuous while the claval suture or fold is very distinct. It is, however, preceded by a conspicuous trachea in all of the genera studied.

#### SECOND AND THIRD ANALS OF THE FORE WING.

The second and third anal tracheæ in the fore wing are well developed and the third anal is frequently two branched (Figs. 3, 5, 6, 20, 23, 25, 41, 46, 60).

#### THE HIND WING.

In all of the *Jassidæ* proper the hind wing is very uniform. No costal or subcostal tracheæ have been discovered although the subcostal vein was well defined in all of the older nymphs studied (Figs. 9, 24, 45, 47).

## RADIUS OF THE HIND WING.

The radius is typically two branched in the hind wing of the *Jassidæ*. Several mounts of *Spangbergiella* (Fig. 21) failed to reveal anything but a single unbranched radial trachea. In the adult hind wing (Fig. 35) there is faint indication of a vein in the position usually occupied by  $R_{2+3}$ .

$R_{2+3}$  reaches its greatest development in *Draeculacephala* (Fig. 7) where it forms the tracheæ that precedes the whole of the ambient vein. In many forms, however, it is very much atrophied (Figs. 24, 45, 47, 65) while in *Empoasca* (Fig. 67) the radius is a simple unbranched trachea. The radius of the *Typhlocybidæ* coalesces for a considerable distance with  $M_{1+2}$  (Figs. 65 and 67).

## MEDIUS OF THE HIND WING.

Medius of the hind wing is two branched in all of the genera that have been examined. In the *Typhlocybidæ*, however,  $M_{1+2}$  coalesces with radius for some distance and  $M_{3+4}$  coalesces with cubitus for almost its entire length so as to appear as a cross vein in the adult wing connecting medius with cubitus (Fig. 80). In the other genera studied  $M_{1+2}$  is connected with  $R_{4+5}$  by a short cross vein and  $M_{3+4}$  is connected with cubitus by a similar short cross vein. In some cases the latter cross vein is greatly reduced and in *Jassus* (Fig. 69)  $R_{4+5}$  and  $M_{1+2}$  coalesce for a short distance and again separate before reaching the margin of the wing.

In all of the genera studied cubitus is a single unbranched trachea in the hind wing. Its relations with medius in the *Typhlocybidæ* have already been discussed. As in the fore wing, cubitus and first anal are very closely united. Second and third anal are also present in nearly all cases and third anal is frequently two branched. The second anal and the anterior branch of the third anal generally coalesce for a considerable distance near the middle of their course and are usually separated again near the base of the wing (Figs. 16, 38, 57). There is always a conspicuous fold just posterior to the anterior branch of the third anal.

## HISTORICAL DISCUSSION.

A comparison of the nomenclature here suggested with the nomenclature current in America and with the nomenclature as suggested by Edwards '94-96 is given in the subjoined table.

## NOMENCLATURE OF VEINS

TERMINOLOGY SUGGESTED	AFTER EDWARDS	CURRENT TERMINOLOGY
Subcosta		Costal border
R+M	Cubital	First sector
Radius	Upper branch of cubital	Outer branch of first sector
R <sub>1</sub>		Nodal
R <sub>2</sub>	Angular	Nodal
R <sub>2+3</sub>		Anterior branch of outer sector
R <sub>3</sub>		
R <sub>4+5</sub>		Posterior branch of outer sector
R <sub>4</sub>		
R <sub>5</sub>		
Medius	Lower branch of cubital	Inner branch of first sector
M <sub>1+2</sub>		
M <sub>3+4</sub>		
Cubitus	Brachial	Second sector
Cu <sub>1</sub>		
Cu <sub>2</sub>		
Anal furrow	claval suture	claval suture
First Anal		
Second anal	anal	outer claval
Third anal	axillary	inner claval
Ambient		

## NOMENCLATURE OF THE CELLS

TERMINOLOGY SUGGESTED	AFTER EDWARDS	CURRENT TERMINOLOGY
Subcosta	costal	
Radius	subcosta	
R <sub>1</sub>		
R <sub>2</sub>	Apical	apical
First R <sub>3</sub>	subapical	anteapical
Second R <sub>3</sub>	apical	apical
First R <sub>5</sub>	apical	anteapical
Second R <sub>5</sub>	apical	apical
First Medius	basal	
Second Medius	superbrachial	
First M <sub>4</sub>	Subapical	anteapical
Second M <sub>4</sub>	apical	apical
Cubitus	brachial	
Cu <sub>1</sub>	apical	apical

## SUMMARY.

The present paper homologizes the wing veins of *Jassidæ* with the wing veins of other orders. The wing veins of *Jassidæ* differ in the following important respects from those of other insects.

1. The costal trachea is practically eliminated from the wings of *Jassidæ*.

2. The subcostal trachea is well developed in some genera and absent in others, which indicates that it is disappearing from *Jassidæ*.

3. The radial trachea is typically two branched in *Jassidæ*, the branches present being  $R_{2+3}$  and  $R_{4+5}$ .

4. The medial trachea is typically two branched, these branches being  $M_{1+2}$  and  $M_{3+4}$ .

5. The cubital trachea is two branched in some cases and unbranched in others.

6. All three anal trachea are present, the first anal being very closely connected with cubitus. Third anal is frequently two branched.

7. The ambient vein is a composite vein in *Jassidæ*, being formed along the overlapping tips of the principal trachea.

## ACKNOWLEDGMENTS.

The writer wishes to express his appreciation to the following persons who have assisted in the preparation of this paper: Professor Herbert Osborn, Mr. R. L. Webster, Mr. Franklin Sherman, Jr., Mr. C. L. Metcalf and Mrs. Luella Correll Metcalf.

The writer also wishes to express his indebtedness to the writings of Osborn and Ball on the *Jassidæ* of North America, without which the work of preparing this paper would have been much more difficult.

## REFERENCES.

- Ball, E. D.**—1901. A Review of the Tettigonidæ of North America, North of Mexico. Proc. Iowa Acad. Sc. VIII: 35-75.
- Ball, E. D.**—1907. The genus *Eutettix*. Proc. Davenport Acad. Sc. XII: 27-94.
- Comstock, J. H.** and **Needham, J. G.**—1898-1899. The Wings of Insects. Amer. Nat. Chapter III: 243-249.
- Gillette, C. P.**—1898. American Leaf Hoppers of the Subfamily Typhlocybinæ. Proc. U. S. Nat. Mus. XX: 709-773.
- Edwards, J.**—1894-1896. The Hemiptera Homoptera of the British Islands. Parts I-VIII.
- Melichar, L.**—1896. Cicadinen von Mittel-Europa.
- Patch, Edith M.**—1909. Homologies of the Wing Veins of the Aphididæ, Psyllidæ, Aleurodidæ and Coccidæ. Ann. Ent. Soc. of America. II: 101-129.
- Osborn, H.**—1900. The Genus *Scaphoideus*. Jour. Cin. Soc. Nat. Hist. XIX: 187-209.
- Osborn, H.**—1905. *Jassidæ* of New York State. 20th Rept. State Ent. of New York. 498-545.
- Osborn, H.**—1911. Remarks on the Genus *Scaphoideus* with a Revised Key and New American Species. Ohio Nat. XI: 249-261.
- Osborn, H.** and **Ball, E. D.**—1897. Contributions to the Hemipterous Fauna of Iowa. Proc. Iowa Acad. Sc. IV: 172-234.
- Osborn, H.** and **Ball, E. D.**—1898. Studies of North American Jassoidea. Proc. Davenport Acad. Nat. Sc. VII: 45-100.
- Osborn, H.** and **Ball, E. D.**—1902. A Review of the North American Species of *Athysanus* (*Jassidæ*) Ohio Nat. II: 231-256.
- Signoret, V.**—1878. Essai sur les Jassides.
- Van Duzee E. P.**—1892. A Synoptical Arrangement of the Genera of the North American *Jassidæ* with Descriptions of some new species. Trans. Am. Ent. Soc. XIX: 295-307.
- Van Duzee, E. P.**—1894. A catalogue of the Described Jassoidea of North America. Trans. Am. Ent. Soc. XXI: 245-317.
- Van Duzee, E. P.**—1908. Observations on some Hemiptera taken in Florida in the Spring of 1908. Bull. Buffalo Soc. Nat. Sc. IX: 149-230.

## EXPLANATION OF PLATES.

## PLATE VIII.

- Fig. 1. Fore wing pad of *Agallia 4-punctata* Prov.  
 " 2. Hind " " *Agallia 4-punctata* Prov.  
 " 3. Fore " " *Oncometopia undata* Fabr.  
 " 4. Hind " " *Oncometopia undata* Fabr.  
 " 5. Fore " " *Diedrocephala coccinea* Forst.  
 " 6. Fore " " *Draeculacephala mollipes* Say.  
 " 7. Hind " " *Draeculacephala mollipes* Say.  
 " 8. Fore " " *Gypona 8-lineata* Say.  
 " 9. Hind " " *Gypona 8-lineata* Say.

## PLATE IX.

- Fig. 10. Fore wing of *Agallia constricta* Van Duzee.  
 " 11. Hind " " *Agallia constricta* Van Duzee.  
 " 12. Fore " " *Oncometopia undata* Fabr.  
 " 13. Hind " " *Oncometopia undata* Fabr.  
 " 14. Fore " " *Diedrocephala coccinea* Forst.  
 " 15. Fore " " *Draeculacephala mollipes* Say.  
 " 16. Hind " " *Draeculacephala mollipes* Say.  
 " 17. Fore " " *Penthimia americana* Fitch.  
 " 18. Fore " " *Gypona 8-lineata* Say.  
 " 19. Hind " " *Gypona 8-lineata* Say.

## PLATE X.

- Fig. 20. Fore wing pad of *Spangbergiella vulnerata* Uhler.  
 " 21. Hind " " *Spangbergiella vulnerata* Uhler.  
 " 22. Fore " " *Athysanus* sp.  
 " 23. Fore " " *Parabolocratus viridis* Uhler.  
 " 24. Hind " " *Parabolocratus viridis* Uhler  
 " 25. Fore " " *Goniagnathus palmeri* Van Duzee.  
 " 26. Fore " " *Platymetopius* sp.  
 " 27. Hind " " *Platymetopius* sp.  
 " 28. Fore " " *Deltocephalus* sp.  
 " 29. Hind " " *Deltocephalus* sp.

## PLATE XI.

- Fig. 30. Fore wing *Xerophloca viridis* Fabr.  
 " 31. Fore " " *Spangbergiella vulnerata* Uhler.  
 " 32. Hind " " *Athysanus exitiosus* Uhler.  
 " 33. Fore " " *Athysanus exitiosus* Uhler.  
 " 34. Fore " " *Parabolocratus viridis* Uhler  
 " 35. Hind " " *Spangbergiella vulnerata* Uhler.  
 " 36. Fore " " *Goniagnathus palmeri* Van Duzee.  
 " 37. Fore " " *Platymetopius* sp.  
 " 38. Hind " " *Platymetopius* sp.  
 " 39. Fore " " *Deltocephalus oblectus* O. & B.  
 " 40. Hind " " *Deltocephalus oblectus* O. & B.

## PLATE XII.

- Fig. 41. Fore wing pad of *Acinopterus acuminatus* Van Duzee.  
 " 42. Hind " " *Acinopterus acuminatus* Van Duzee.  
 " 43. Fore " " *Chlorotettix viridia* Van Duzee.  
 " 44. Fore " " *Scaphoideus* sp.  
 " 45. Hind " " *Scaphoideus* sp.  
 " 46. Fore " " *Eutettix* sp.  
 " 47. Hind " " *Eutettix* sp.  
 " 48. Fore " " *Phlepsius* sp.  
 " 49. Hind " " *Phlepsius* sp.

## PLATE XIII.

- Fig. 50. Fore wing of *Acinopterus acuminatus* Van Duzee.  
 " 51. Hind " *Acinopterus acuminatus* Van Duzee.  
 " 52. Fore " *Chlorotettix viridia* Van Duzee.  
 " 53. Fore " *Scaphhoideus productus* Osb.  
 " 54. Hind " *Scaphhoideus productus* Osb.  
 " 55. Fore " *Thamnotettix kennicottii* Uhler.  
 " 56. Fore " *Eutettix subaenea* Van Duzee.  
 " 57. Hind " *Eutettix subaenea* Van Duzee.  
 " 58. Fore " *Phlepsius* sp.  
 " 59. Hind " *Phlepsius* sp.

## PLATE XIV.

- Fig. 60. Fore wing pad of *Jassus olitorius* Say.  
 " 61. Hind " " *Jassus olitorius* Say.  
 " 62. Fore " " *Cicadula* sp.  
 " 63. Hind " " *Cicadula* sp.  
 " 64. Fore " " *Typhlocyba* sp.  
 " 65. Hind " " *Typhlocyba* sp.  
 " 66. Fore " " *Empoasca mali* Le B.  
 " 67. Hind " " *Empoasca mali* Le B.

## PLATE XV.

- Fig. 68. Fore wing of *Jassus olitorius* Say.  
 " 69. Hind " *Jassus olitorius* Say.  
 " 70. Fore " *Cicadula slossoni* Van Duzee.  
 " 71. Hind " *Cicadula slossoni* Van Duzee.  
 " 72. Fore " *Dicraneura mollicula* Bohem., redrawn from Melichar.  
 " 73. Hind " *Dicraneura mollicula* Bohem., redrawn from Melichar.  
 " 74. Fore " *Eupteryx vanduzei* Gill., redrawn from Gillette.  
 " 75. Hind " *Eupteryx vanduzei* Gill., redrawn from Gillette.  
 " 76. Fore " *Dicraneura cruentata* Gill., redrawn from Gillette.  
 " 77. Fore " *Typhlocyba illinoiensis* Gill.  
 " 78. Hind " *Typhlocyba illinoiensis* Gill.  
 " 79. Fore " *Empoasca mali* Le B.  
 " 80. Hind " *Empoasca mali* Le B.

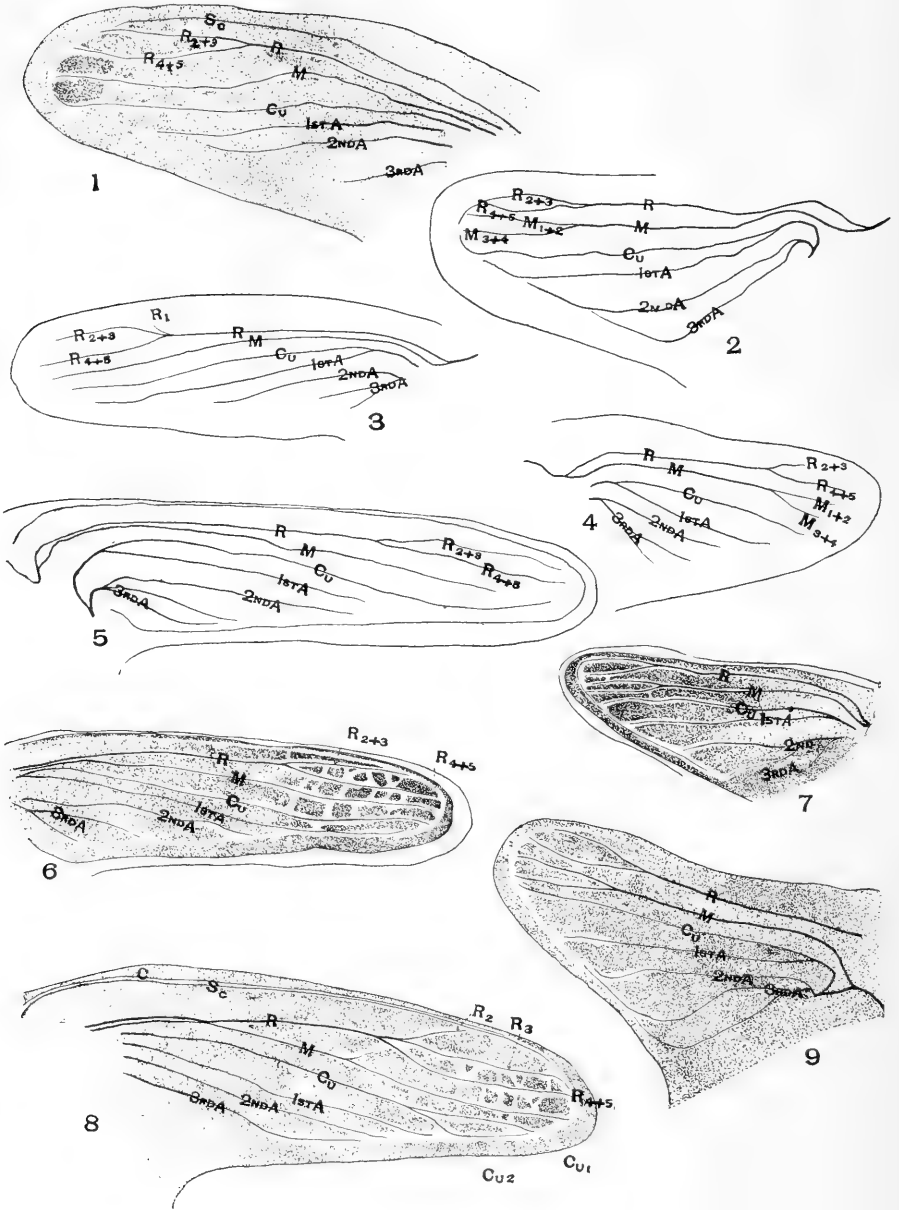



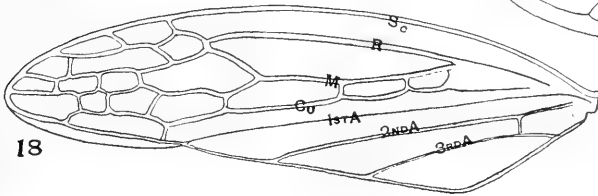
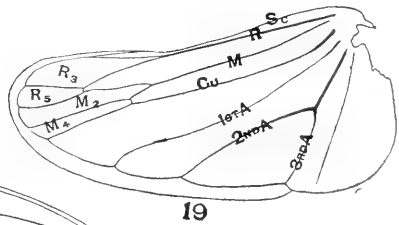
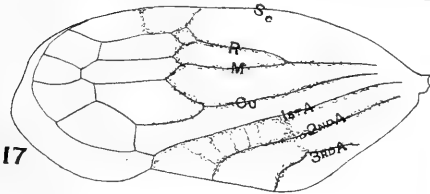
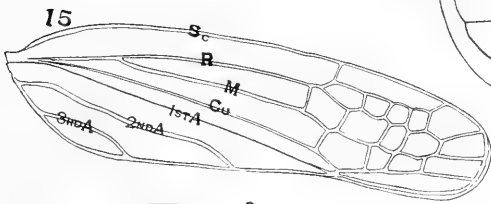
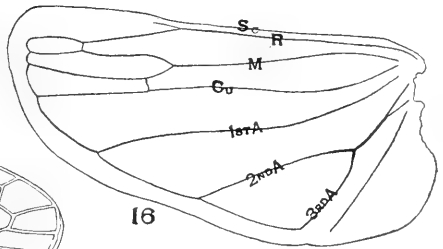
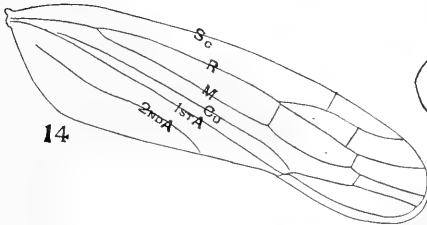
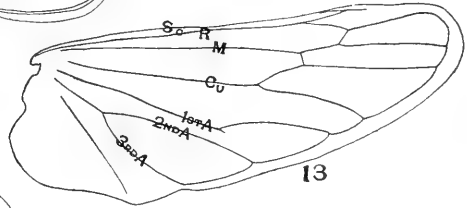
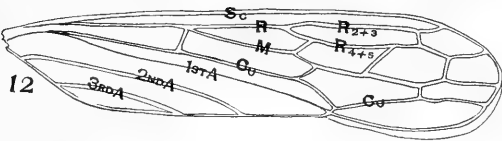
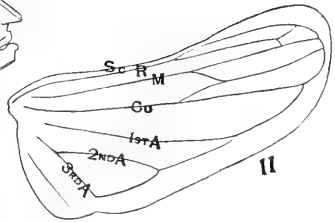
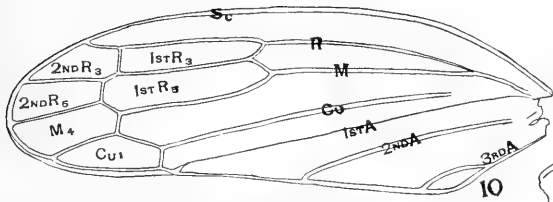

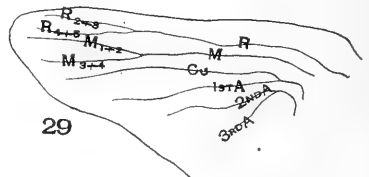
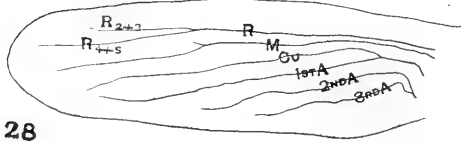
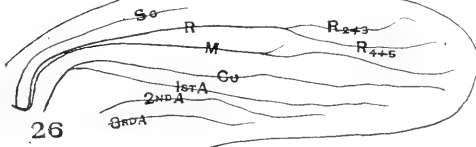
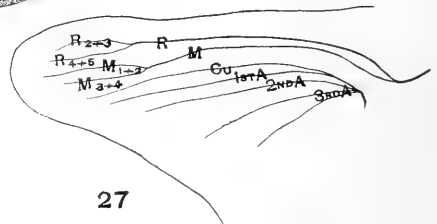
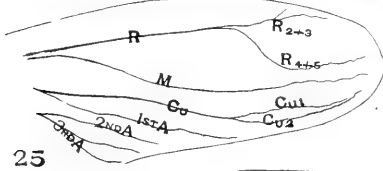
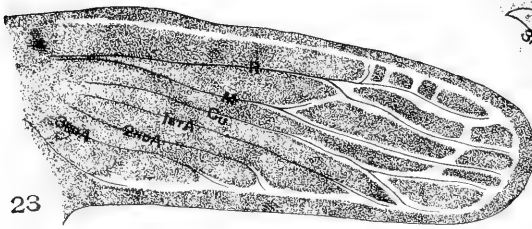
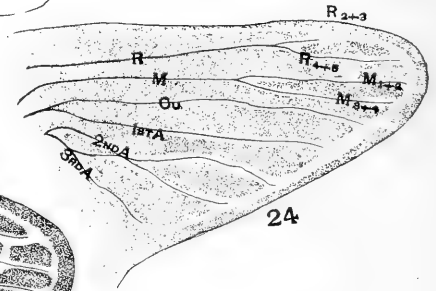
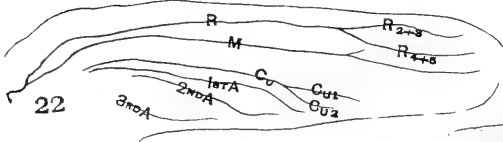
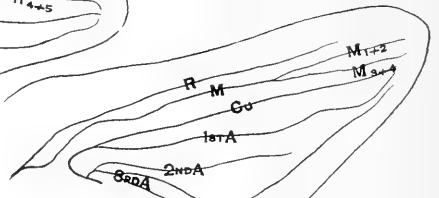
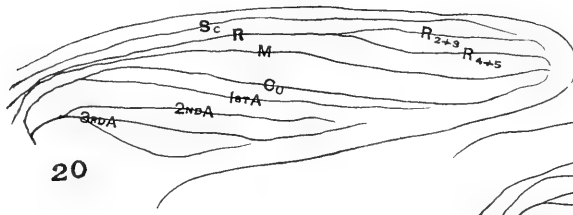

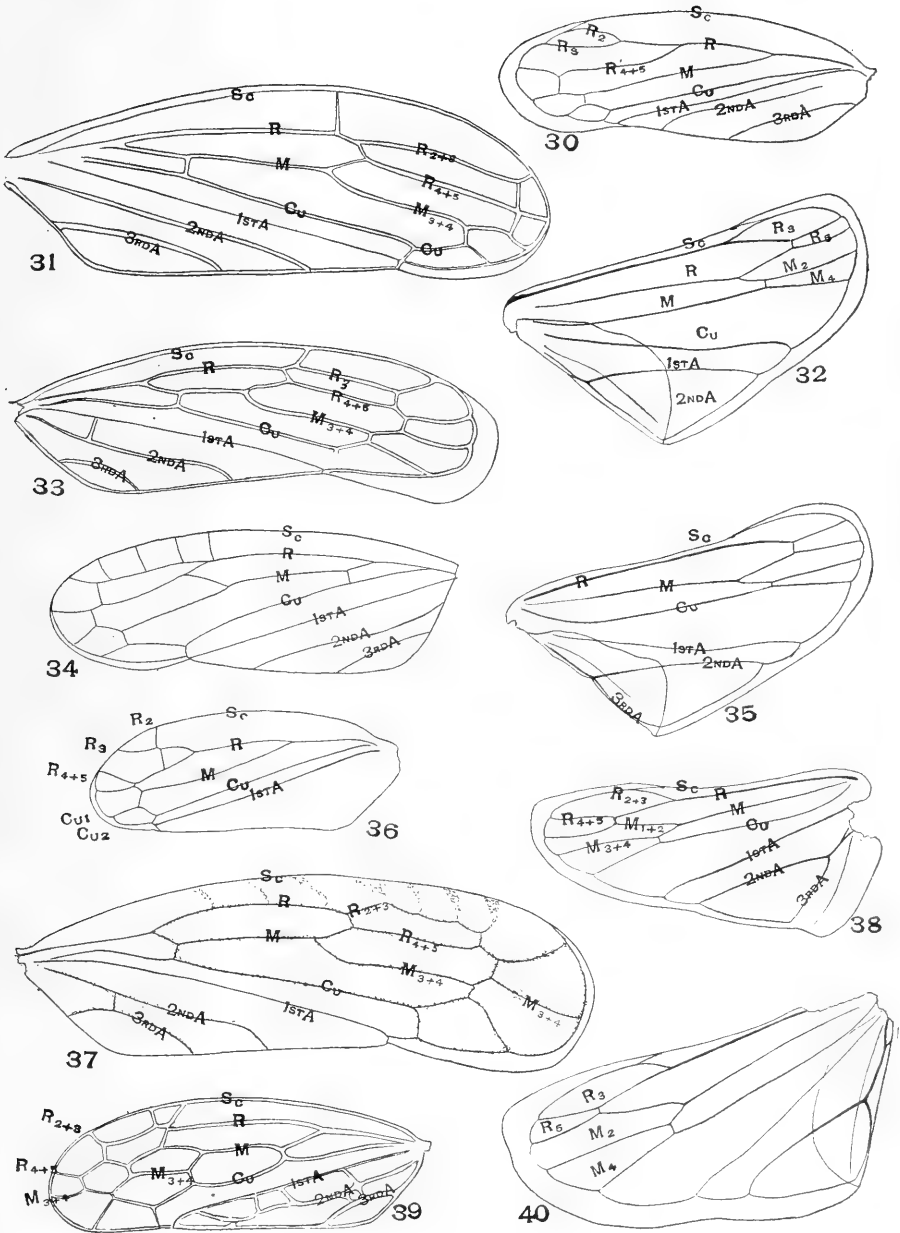

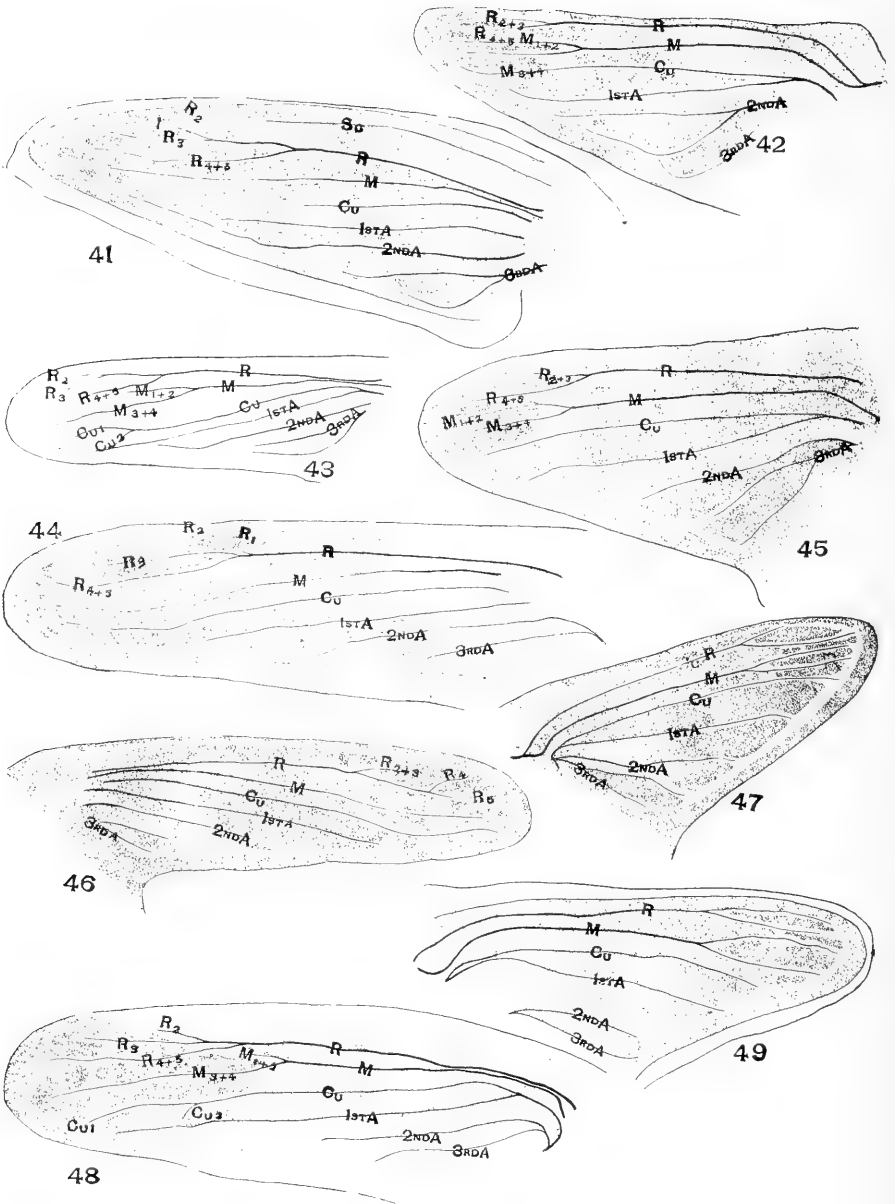

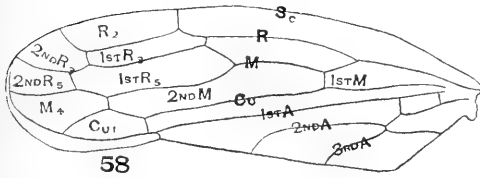
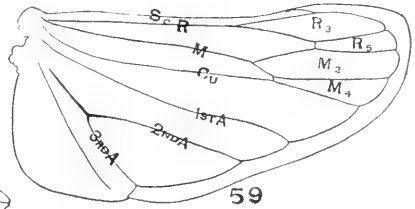
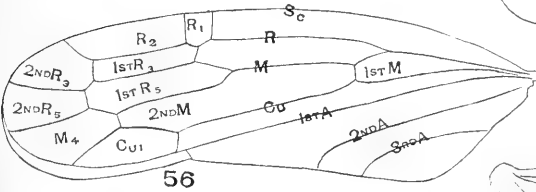
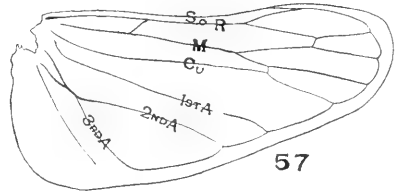
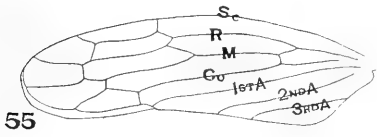
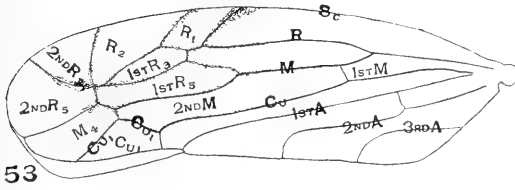
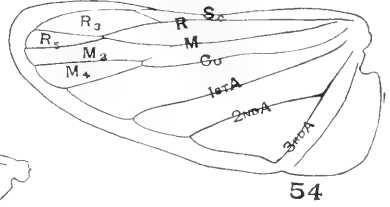
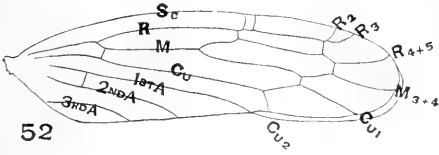
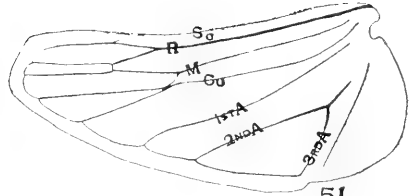
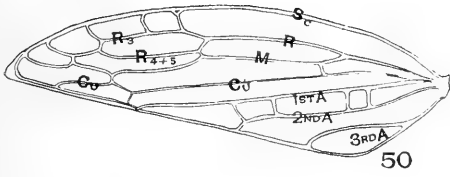

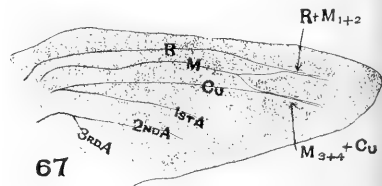
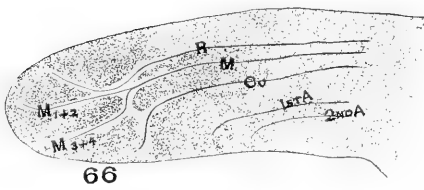
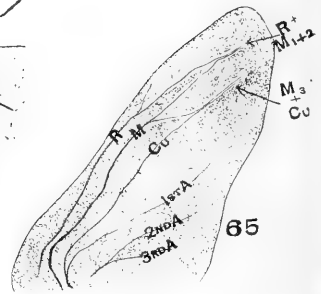
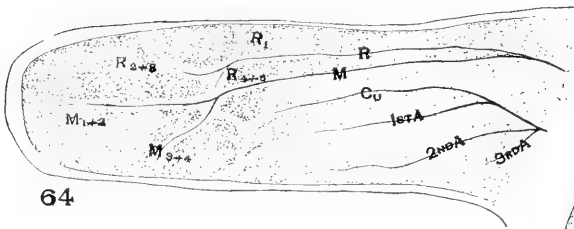
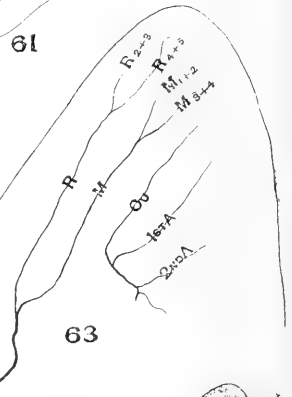
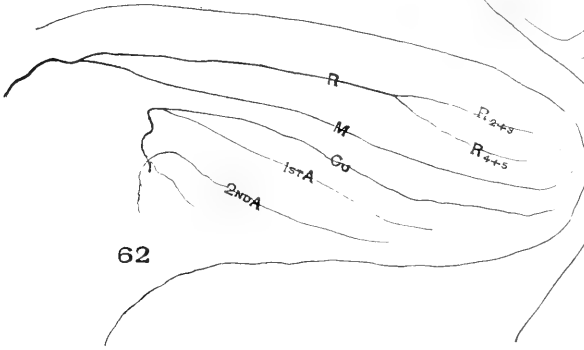
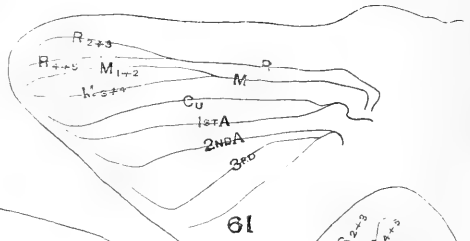
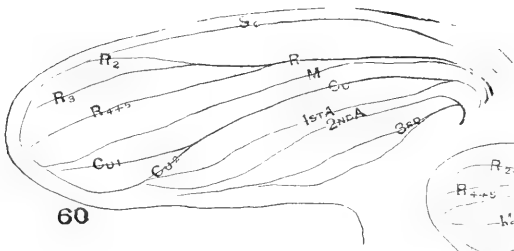

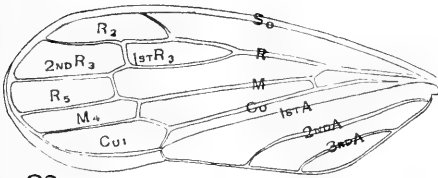

68

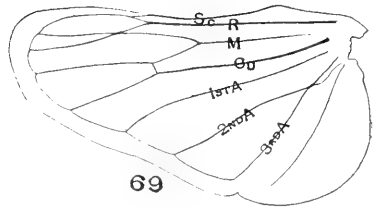

69

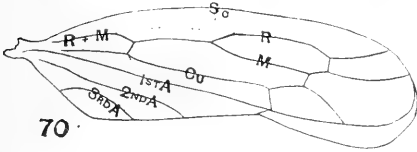

70

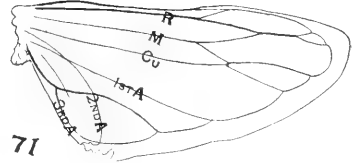

71

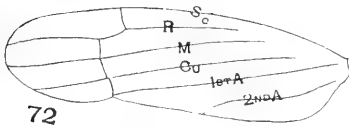

72

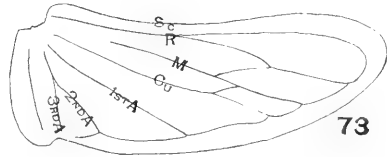

73

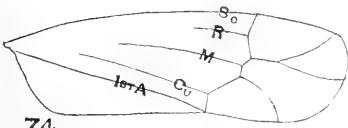

74

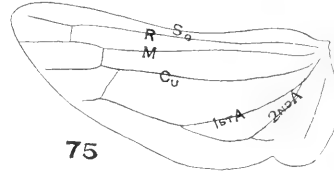

75

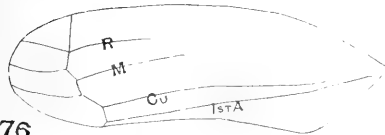

76

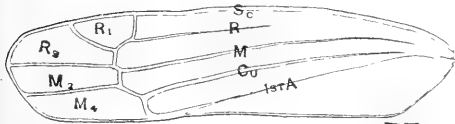

77

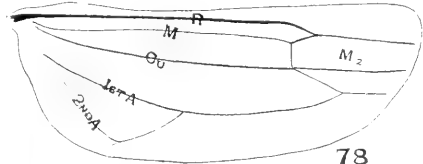

78

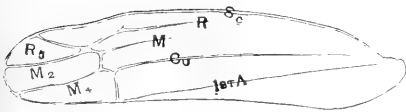

79

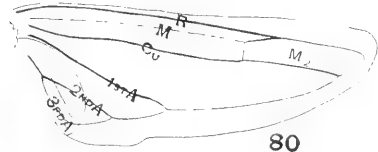

80





## A NEW HYMENOPTEROUS PARASITE ON ASPIDIOTUS PERNICIOSUS COMST.\*

By DANIEL G. TOWER, Amherst, Mass.

This parasite was reared during October, 1912, from *Aspidiotus perniciosus* Comst. at Amherst, Mass. Specimens were sent to Dr. L. O. Howard, who returned them with the statement that they were a new species of *Prospaltella* and could safely be described as such. Acting on this advice the following descriptions of male and female have been prepared, under the supervision of Dr. H. T. Fernald.

This new species can be inserted in Dr. Howard's key to the species of *Prospaltella* (Ann. Ent. Soc. Am., I, 281, 1908), by adding a fourth alternative to section five as follows: "Wings with a broad dusky band below marginal vein, . . . . 6," and by adding to section six the alternative, "Wings with a broad dusky band below marginal vein: abdomen nearly black" which would lead to this species.

### *Prospaltella perniciosi* n. sp.

Female: Length, 0.61 mm.; expanse, 1.73 mm.; greatest width of fore-wing, 0.25 mm. General color of living specimens black with the meso-scutellum showing as a prominent light dot. In zylol-balsam mounts the head and central portions of the thorax are light brown. Head: vertex yellowish brown; occiput dark; ocelli dark; eyes black and hairy, the hairs about as long as the diameter of a facet. Antenna: brownish yellow; bulb twice as long as wide, cylindrical and nearly hyaline; scape nearly five times as long as wide, nearly hyaline at each end, more or less cylindrical to spindle shaped; pedicle slightly longer than wide, narrow at its base, widest well toward its tip, its inner side much farther from the axis of the antenna than its outer side; first funicle segment connected with pedicle by a narrow somewhat elongate stalk, which is quite hyaline; this segment a trifle more than half the length of the next and irregular in outline; second and third segments of the funicle nearly equal in size and nearly cylindrical; segments of the club more closely articulated to each other than to the funicle or than are the segments of the funicle to each other; club slightly longer than funicle; first two segments about equal in length, their greatest diameter being at their outer ends; terminal segment elongate, triangular in outline, and longer than either of the other segments, bluntly pointed at tip; all segments of antenna bearing scattered hairs.

\* Contribution from the Entomological Laboratory, Massachusetts Agricultural College.

Thorax: Pronotum dark; mesoscutum brownish yellow, darker near the anterior edge, mesoscutar parapsida same color or lighter than mesoscutum with a darker spot well forward toward the base of the fore-wing; scapula dark; mesoscutellum noticeably paler than mesoscutum. Behind the mesoscutellum are two narrow transverse plates dark toward their lateral margins and light near the middle, the posterior plate with a spiracle near each lateral margin. Marginal and submarginal veins of fore-wing nearly equal in length; end of stigmal vein obscurely pointed, not reaching wing margin, its upper side slightly emarginated, its anal margin broadly rounded; a broad dusky band crosses the fore-wing below the marginal vein; hind wing lanceolate; legs pale yellow except the coxæ, femora, and basal halves of the tibiæ, these being dark, the coxa being the darkest portion of each leg, those of the hind legs being the darkest; fore-legs as a whole the lightest and the hind legs the darkest; trochanters nearly hyaline.

Abdomen: Short, broad, nearly quadrangular in outline; quite dark with faint transverse lighter bands and a yellowish brown area near the genitalia: with spines directed backward evident on the sides (above and below also?).

Male: Length, 0.56 mm.; expanse, 1.54 mm.; greatest width of fore-wings, 0.26 mm. Living and mounted specimens appear the same as females, except that they are smaller, and the mesoscutellum is not as light in color. The antenna differs in that the first funicle segment is as long as the second, and its diameter at its distal end is greater than the diameter of either of the other two funicle segments. Its base is rounded and stalked, and it does not give the effect of a bead as does the corresponding segment in the female antenna. The articulation between the second and third segments of the club is not as evident as between the first and second segments, while in the female both articulations are very clear and well defined. The thorax as a whole is darker than that of the female, the only light portions being the mesoscutellum and the portion of the mesoscutar parapsida nearest it. The hind margin of the stigmal vein is more angular than in the female. The faintly cloudy band below the marginal vein is hardly distinguishable. The abdomen is short, much narrower than the thorax, truncate, dark and not showing lighter bands, but lighter near the genitalia which extrude, the tips of these being nearly hyaline.

Described from one female type and forty-three paratypes (on twelve slides) and one male type and four paratypes (five slides). The male type (one slide) and the female type with eleven paratypes (one slide) in the collection of the Massachusetts Agricultural College, Amherst.

One male and nine female paratypes (two slides) deposited in the U. S. National Museum (Type No. 15453).

The remaining paratypes male and female together with some female metatypes, have been retained by the author.

ENTOMOLOGICAL SOCIETY OF AMERICA.

*Organized 1906.*

OFFICERS FOR 1913.

*President.*

CHARLES J. S. BETHUNE . . . . . Ontario Agr'l College, Guelph, Ontario

*First Vice-President.*

PHILIP P. CALVERT . . . . . University of Pennsylvania, Philadelphia, Pa.

*Second Vice-President.*

WILLIAM M. MARSHALL . . . . . University of Wisconsin, Madison, Wis.

*Secretary-Treasurer.*

ALEX. D. MACGILLIVRAY . . . . . University of Illinois, Urbana, Ill.

ADDITIONAL MEMBERS OF EXECUTIVE COMMITTEE.

HERBERT OSBORN, Ohio State University, Columbus, Ohio.

C. P. GILLETTE, Colorado Agricultural Experiment Station,  
Fort Collins, Colorado.

VERNON L. KELLOGG, Leland Stanford Jr., University,  
Stanford University, California.

JAMES G. NEEDHAM, Cornell University, Ithaca, New York.

C. T. BRUES, Harvard University, Cambridge, Massachusetts.

NATHAN BANKS, United States National Museum, Washington, D. C.

COMMITTEE ON NOMENCLATURE.

T. D. A. COCKERELL, University of Colorado, Boulder, Colorado, 1913.

H. T. FERNALD, Massachusetts Agr'l College, Amherst, Mass., 1914.

E. P. FELT, New York State Entomologist, Albany, N. Y., 1915.

COUNCILORS FOR THE AMERICAN ASSOCIATION FOR THE  
ADVANCEMENT OF SCIENCE.

CHARLES J. S. BETHUNE, Ontario Agricultural College, Guelph, Ontario.

STEPHEN A. FORBES, University of Illinois, Urbana, Illinois.

EDITORIAL BOARD OF ANNALS.

HERBERT OSBORN, Managing Editor, Ohio State University,  
Columbus, Ohio.

J. H. COMSTOCK, Cornell University, Ithaca, New York.

CHARLES J. S. BETHUNE, Ontario Agricultural College Guelph, Ontario.

C. W. JOHNSON, Boston Society of Natural History, Boston, Mass.

VERNON L. KELLOGG, Leland Stanford Jr., University,  
Stanford University, Cal.

L. O. HOWARD, Chief, Bureau of Entomology, Washington, D. C.

W. M. WHEELER, Harvard University, Cambridge, Massachusetts.

PHILIP P. CALVERT, University of Pennsylvania, Philadelphia, Pa.

J. W. FOLSOM, University of Illinois, Urbana, Illinois.

## RESOLUTIONS

## ON THE DEATH OF JOHN B. SMITH.

John Bernard Smith, D. Sc. Professor of Entomology Rutgers College, Entomologist N. J. Agricultural Experiment Station, Fellow and former President of the Entomological Society of America, died at his home in New Brunswick, New Jersey, on March 12, 1912.

As an ardent collector, systematist, and morphologist; Editor of *Entomologica Americana*; Assistant Curator of Insects in the National Museum; Professor of Entomology, and Entomologist of the Agricultural Experiment Station of New Jersey, Dr. Smith's contributions to American Entomology have been of such extended and valuable character that his name has been and will remain a familiar one to workers in Entomology.

He was a genial friend and companion and remembrance of his personal traits will be treasured as among the lasting possessions of memory among his associates.

As a devoted member and officer in this society he labored faithfully in promoting its welfare and we now resolve that this tribute to his character be printed in the *Annals of the Society* as the public expression of our admiration for the man and our sense of loss in his death.

Committee

HERBERT OSBORN,  
HENRY SKINNER,  
E. P. FELT.



JOHN B. SMITH.







THOMAS H. MONTGOMERY.



## RESOLUTIONS

## ON THE DEATH OF THOMAS H. MONTGOMERY.

In the death of Professor Thomas H. Montgomery, Jr., on March 19, 1912, the Entomological Society of America lost a member whose entomological work was concerned mainly with the Hemiptera and the Araneina, dealing with various phases of the morphology, embryology and ecology of these groups in themselves, and as furnishing material for studies on the deeper problems of inheritance and sex-determination. He did not confine himself to these groups of animals but extended his researches to other non-entomological fields of zoology and in all he made valuable contributions to knowledge and to theory.

In appreciation of his accomplishments and in sorrow at his early death, we enter this record on our minutes and extend to Mrs. Montgomery our deep sympathy in her and our loss.

Committee      PHILIP P. CALVERT,  
                         HENRY SKINNER,  
                         J. H. COMSTOCK.

## PROCEEDINGS OF THE ENTOMOLOGICAL SOCIETY OF AMERICA.

### Cleveland Meeting.

The seventh annual meeting of the Entomological Society of America was called to order by President Stephen A. Forbes at 10:00 A. M., Tuesday, December 31st, in the Auditorium of the Normal School. All the meetings of the Society were well attended, seventy-five or more at each session, and it was pronounced by several the best meeting of the Society that they had attended. The following committees appointed previous to the meeting, were named:

Committee to draft resolutions on the death of Dr. John Bernhardt Smith—Herbert Osborn, Henry Skinner, E. P. Felt.

Committee to draft resolutions on the death of Dr. Thomas Harrison Montgomery, Jr.—Philip P. Calvert, Henry Skinner, J. H. Comstock.

The chair was directed by motion to appoint the following committees: Committee on Resolutions; Committee on Nominations; Auditing Committee.

The following papers were then read:

*C. Betten, Lake Forest University; An Interesting Feature in the Venation of Helicopsyche, the Molannidæ, and the Leptoceridæ.* (Printed in this number of Annals).

Discussion: W. A. Riley—Dr. Betten's interpretation of the modifications of  $R_5$  is especially interesting as still further emphasizing the close relationship in wing venation between the Trichoptera and the Lepidoptera. The lepidopterous wing venation exhibits specialization by reduction and Dr. Betten has clearly demonstrated that what has been regarded as an accessory vein is really a branch of a primary vein.

*Lucy W. Smith, Mt. Holyoke College: Mating and Egg-laying Habits of Perla immarginata.* (To appear in June number of Annals.)

*Alvah Peterson, University of Illinois: Head and Mouth parts of Cephalothrips yuccæ.*

A preliminary report on the asymmetry of the mouth-parts of Thysanoptera. A detailed description of the anatomy of the mouth-parts and head capsule of *Cephalothrips yuccæ*, a species belonging to the suborder Tubulifera, was given. Numerous details and parts heretofore undescribed as to mandibles, hypopharynx, epipharynx, arms of tentorium, etc., were shown. Similar observations were made on *Anthothrips verbasci* in order to verify results found in *Cephalothrips yuccæ*.

Comparing the work done by H. Garman on *Limothrips cerealium*, a species of Terebrantia, with the work done by Muir and Kershaw, on a species of Tubulifera, a difference in interpretation exists as to whether the asymmetrical parts are mandibles or maxillæ. Muir and Kershaw interpret the asymmetrical parts as maxillæ. Observations made by the writer on two species of Tubulifera verify their position in general. The writer expects to continue his observations on species of the sub-order Terebrantia to determine if possible whether the interpretation of H. Garman is correct or not.

Discussion: R. A. Cooley—It was asked as to whether any evidence of glandular secretion from the mouth was found, which being answered in the negative, it was stated that in a species feeding on terminals of currant and gooseberry we have noticed a considerable distortion of the leaves and stem, suggesting the possibility of a secretion introduced while feeding.

*J. E. Wodsedalek, University of Wisconsin: Life History and Habits of Trogoderma tarsale, a Museum Pest.* Read by Title.

*Leonard Haseman, University of Missouri: Life Cycle and Development of the Tarnished Plant Bug, Lygus pratensis Lin.* Presented by the Secretary.

Owing to the very serious injury to peach and pear in the early spring which seemed to be due to the work of the tarnished plant-bug, the writer has undertaken a careful study of the life cycle, habits and development of this insect. The work has been carried through the late summer and fall months and will be continued throughout the following spring and summer.

In this work it has been found that the tarnished plant-bug breeds largely upon various flowering weeds such as wild asters, daisies, and mare's tail (*Erigeron canadensis*). The tarnished plant-bug deposits its eggs in the blossoms of the host plant and not in the tissue of the leaves or stems. These eggs hatch in from five to seven days and the insect passes through five distinct nymphal stages in its development in the place of four, as other writers have maintained. The insect remains in each nymphal stage for about the same length of time and completes its growth in from thirty to thirty-five days.

Discussion: P. J. Parrott—There occurs in New York a species (*Lygus invitus*) Say which is during some seasons quite destructive to pears. In feeding on the fruit, the epidermis is ruptured by the proboscis and protruding granular areas form about the wounds. This species closely resembles *pratensis* and is easily confused with it. In order to establish distinguishing characters we have bred the two insects through their various life stages. Both species have five nymphal instars and can

easily be separated by certain characters which we hope to explain later. I noted with much interest the remarks on oviposition habits of *pratensis*, and I would also add that we have obtained the eggs of this species from ripe strawberries, raspberries and blackberries, and for rearing the insect during its various nymphal stages we have found nothing more satisfactory than the berries of these different fruits.

*Victor E. Shelford, University of Chicago: The Ontogeny of Elytral Pigmentation in Cicindela.*

The pigment develops in the form of a faint pattern, somewhat variable but with certain lighter areas occurring in the same general position in several species. These lighter areas lie between the tracheæ and in certain transverse bands: their positions correspond to those of certain white markings of Ethiopian and Oriental species.

Discussion: Miss Annette Braun—The question was raised as to whether the position of the dark transverse bands on the elytra of *Cicindela* is determined by structural characters of the elytra, citing work on the ontogeny of wing pattern in certain moths where the position of the tip of the veins decides the position of markings, the tip of the vein remaining unpigmented.

V. E. Shelford. The dark cross bands which separate the spots are not correlated with any known elytral structures. There is no evidence of metamerism in the wing. The pigment develops throughout the elytron, the base does not appear oldest.

*N. L. Partridge, University of Illinois: The Tracheation of the Pupal Wings of some Saturnians.*

A method of preparing permanent mounts of lepidopterous pupal wings was described. The pupal wings were removed in the customary manner and the specimens secured, floated upon clean water to straighten the wings and remove any dirt which might adhere to them. Then they were placed on a clean, untreated, glass slide, smoothed, and allowed to dry, without further treatment. The result was a transparent mount showing all the tracheoles as well as the tracheæ. Some of these mounts were used as lantern slides giving clear images on the screen.

It was shown that a greater amount of variation was found in the pupal wings than in the adult wings. The homologies between the tracheæ and veins of the specimens shown was indicated.

*L. B. Walton, Kenyon College: Studies on the Mouth-parts of Rhyarobia maderiæ (Blattidæ) with a consideration of the Homologies existing between the Appendages of the Hexapoda.*

The question as to the homologies existing among the paired appendages of the Hexapoda has received attention from various investigators,

and in particular from Hansen, Heymons, Börner, Verhoeff, and Esch-erich, none of whom however have progressed far toward a satisfactory solution of the problem. In general it has been accepted that the stipes and mentum correspond to the thoracic and abdominal coxæ while the maxillary and labial palpi were equivalent to the trochanter, femur, etc., or the functional leg.

Studies on *Rhyparobia maderiæ* the "giant cockroach" from Panama, particularly of 10 mm. and 12 mm. embryos, as well as other investigations in connection with the appendages of the Thysanura, make it evident that the typical appendage (mouth-parts, thoracic, abdominal, caudal) of the Hexapoda consists of seven definite areas best represented by the maxillæ with the galea, lacina, ectostipe,<sup>1</sup> endostipe, ectocardo, endocardo, and palpus. Furthermore the palpus should be homologized with the stylus of the thoracic and abdominal coxæ and not with the functional leg, inasmuch as both palpus and stylus are appendages of homodynamous areas (ectostipe, ectomentum, meron) while the leg is an appendage of the area (endocoxa) corresponding to the endostipes.

The facts noted suggest the origin of the biramous appendage of the Hexapoda directly from the parapodium of the Polychaeta, the notopodium and neuropodium arising in connection with the dorsal and ventral bundles of setæ and corresponding to the outer (ectal) and inner (endal) groups of sclerites as outlined above. It would thus appear that the Arthropoda are a polyphyletic group, and that the relationship between the appendages of the Hexapoda and Crustacea is a more remote one than generally accepted in connection with the studies of Hansen and Börner.

The historical development of the problem as well as the presentation of the facts which would seem to establish the views here advanced, will appear in the completed paper of which this is a partial summary.

Discussion: W. A. Riley—I have been especially interested to learn that Dr. Walton is swinging away from his earlier belief in the double nature of the insect segment. It has seemed to me that embryological data afforded no evidence in support of the theory though there are indications of the biramous nature of the appendages. The theory of the origin of the insect appendages from the pleuropodes receives much additional support from the work here presented.

The President announced the following committees:

Committee on Resolutions—S. J. Hunter, W. A. Riley, and L. B. Walton.

Committee on Nominations—Herbert Osborn, R. A. Cooley, and Cornelius Betten.

Auditing Committee—P. J. Parrot, A. F. Burgess, and W. E. Britton.

1. The prefixes "ecto" and "endo" have been utilized in an attempt to establish a better nomenclature while minor changes have been made in the terminology of older parts, e. g. "ectostipes" is a more cumbersome term than "ectostipe."

The Society then adjourned to meet at 2:00 p. m. when the following business was transacted and papers read:

The Committee appointed to draft resolutions on the death of Dr. John Behrnhardt Smith presented their report. It was ordered accepted and printed.

*James Zetek, Sanitary Commission Canal Zone: Determining the Flight of Mosquitoes.* Read by Title.

*William A. Riley, Cornell University: Some Sources of Laboratory Material for Work on the Relation of Insects to Disease.*

The demand for at least elementary courses on the relation of insects to disease brings up the question as to available laboratory material. There is comparatively little difficulty in obtaining the parasitic mites, ticks, lice, house-flies, mosquitoes and fleas in their various stages, but it is usually assumed that most of the pathogenic Protozoa are tropical species and that nothing can be substituted for them in laboratory work. As a matter of fact, a number of insect-borne Protozoa and worms occur in this country and together with other blood parasites whose life-history is less better known, are available for laboratory work. The species discussed were *Trypanosoma lewisi* a widely distributed parasite of brown rats; *Trypanosoma rotatorium* from the frog; the related *Corithidia* from the "sheep tick"; *Herpetomonas* from the house-fly; *Monocystis* from the seminal vesicles of the earth worm as introductory to the study of the Hæmosporidia; *Lankesterella ranarum* *Haemogregarina* sp.; *Proteosoma*, *Halteridium*, *Babesia hilaria* in the blood of the crow and English sparrow, and *Dipylidium caninum*, the double-spored tape worm of dogs, cats, and man.

Discussion: F. L. Washburn—It was asked whether Dr. Riley had ever found acridids killed by the presence of an excessive number of gregarines. Being answered in the negative, it was stated that a party in western Oregon had recently written him of the occurrence of large swarms of locusts in the Willamette valley which did not lay eggs, but perished in large numbers and a microscopical examination disclosed a very large number of gregarines in each insect and the reproductive glands entirely disintegrated.

*Y. H. Tsou and S. B. Fracker, University of Illinois: The Homology of the Body Setæ of Lepidopterous Larvæ.*

This paper consisted (1) of a statement of the difficulties involved in homologizing the body setæ of these larvæ, (2) of a consideration of the serial homology of the setæ of the different segments and (3) of the specific homology in the larger groups. Greek letters were employed to designate the setæ in order to obviate the confusion which has arisen from the use of numbers in different ways by different authors. The

prothorax of *Hepialus* was shown to represent the primitive arrangement of setæ and was used as a type for determining the homology of the setæ on the different segments. The authors had studied many species and gave figures of four: *Hepialus lectus* and *H. humuli* of the Jugatæ, *Pseudanaphora arcanella* of the Tineidæ and *Mamestra picta* of the Noctuidæ. Each of these was compared with the type, segment for segment. This is the first time the setæ of the prothorax have been homologized with those of the other segments.

Discussion: W. A. Riley—I wish to speak in appreciation of the important work which Mr. Tsou and Mr. Fracker have reported upon—work which is especially difficult to present in a non-technical manner. It is quite customary to ridicule work upon such a subject as the “hair of a caterpillar” and even some entomologists are inclined to question the possibility of homologizing such structures. Yet, as Professor Comstock sometimes says, “We read that the very hairs of our head are numbered, and in the case of lepidopterous larvæ this may be literally true”. That certain hairs or groups of hairs may be persistent and may be homologized throughout a wide series of forms, is due to the fact that they possess important sensory functions. Pioneer work in this country on the homologizing of setæ was done by Dyer, and the late C. B. Simpson extended this by an important study which is deposited as a thesis in the Cornell University library. It is gratifying to see the work continued under Dr. MacGillivray who is best qualified to supervise it.

*Anna H. Morgan, Mt. Holyoke College: Eggs and Egg-laying of May-flies.*

This study of May-fly eggs was made to determine the relative fecundity of different species. This led to the study of a series of elaborate sculpturings found upon the chorion. In several species the chorion bears long thread like extensions which terminate in viscid spheres or disks. These seem to help buoy up the eggs. Threads two and three inches long were found. In nature these threads are probably entangled in sticks and vegetation and this prevents the eggs from being covered by silt. In the ovaries of half grown nymphs these structures are well defined and are of aid in connecting up the life histories where rearing is impossible.

Discussion: Philip P. Calvert—It was remarked that Miss Morgan's statements that *Heptagenia interpunctella* and *H. pulchella* closely resembled each other as adults and lived in the same situation as larvæ and eggs might seem to indicate an exception to Jordan's law that the nearest related species are

always separated from each other by some kind of a barrier, but in view of the great differences in the eggs of the two species, it might be doubtful whether these two species are really so closely related. It is therefore evidently necessary to know all the stages of two species before one can pronounce on their relationships and whether they do or do not contradict the law mentioned.

*Herbert Osborn, Ohio State University: Notes on Cicadidæ with Especial Reference to the Ohio Species.*

Cicadas constitute a conspicuous element in an Insect fauna and their relation to varied forest conditions was discussed especially for the species occurring in Ohio. The origin and function of the tympanal organs present problems for study and the suggestion is made that this structure is primarily a secondary sexual character functioning in sexual excitation and only incidentally a sound producing organ.

*Frank E. Lutz, American Museum Natural History: On the Biology of *Drosophila ampelophila*.*

This insect is remarkably useful in laboratory work since it can be kept going throughout the year on bananas as food and its short life-cycle (about ten days to two weeks) enables one to get a large number of generations. Sexual difference characterizes the insect. Not only do the sexes differ in adult color and structure but they differ in the duration of the immature stages, in their reactions to light and the age at death.

*E. P. Felt, State Entomologist, New York: Observations on the Biology of a Blow Fly and a Flesh Fly.*

A study of *Phormia regina* Meign. and *Sarcophaga georgina* Wied. was undertaken primarily for the purpose of obtaining data which could be used as a basis for estimating the period a human body had lain exposed to the elements in midsummer. Our knowledge of these two species is summarized and original data are given of the habits and duration of the various stages under known climatic conditions. The egg of *Phormia* and the three larval stages and puparium of both species are described and a bibliography of each appended.

The Society adjourned at 4:30 p. m., to meet Wednesday, January 1st, at 10:00 a. m.

The annual business meeting of the Society was held upon reconvening and the following reports presented:

The Secretary presented the following report for the Executive Committee, which met at the Hotel Euclid, Tuesday evening, December 31.



## REPORT OF THE EXECUTIVE COMMITTEE.

Your Secretary asks the privilege of departing from the custom of former secretaries in reporting the various matters that have been submitted to the Executive Committee in the interim between meetings. The secretary feels that all these matters should be reported at the annual meeting of the Executive Committee and put on record in the proceedings of the Society.

The following matters were considered during the year 1912:

1. The revision of By-Law No. 9 as reported in the Annals, Vol. V, p. 83.

2. The appointment of Professor Herbert Osborn, the retiring President, as the second counselor of the Society to the American Association for the Advancement of Science.

3. The following were named as delegates to the second International Congress of Entomologists, held at Oxford, England, August 5-10, 1912:

Professor J. H. Comstock, Dr. Henry Skinner, Dr. W. J. Holland, Professor V. L. Kellogg, Dr. Philip P. Calvert, Dr. L. O. Howard, Dr. W. M. Wheeler, Professor Herbert Osborn, Professor S. A. Forbes, and Professor J. G. Needham.

4. The appointment of a committee of three to draft resolutions inviting the International Congress of Entomology to hold its next meeting, 1915, in America. The following were named: Professor S. A. Forbes, Chairman; Dr. Henry Skinner, and Professor J. H. Comstock. The success attending the efforts of this committee are reported in another place.

5. That there be printed at the head of the list of papers on the program for each annual meeting the following statement: Each paper will be limited to fifteen minutes, second titles will be placed at the end of the program and read in the order listed.

Upon an invitation from the Academy of Natural Sciences of Philadelphia, the President named the following as delegates to the celebration of the centenary anniversary of the academy: Professor John B. Smith, Dr. L. O. Howard, Dr. E. P. Felt, Dr. W. E. Britton, and Dr. W. M. Wheeler.

The following twenty-seven new members were elected by the Executive Committee, June 1, 1912:

J. Lyonel King.	H. R. Niswonger.	James McDunnough.
H. M. Parshly.	C. L. Metcalf.	Miss E. D. Faville.
M. M. High.	Prof. O. W. Oestlund.	N. L. Partridge.
E. H. Strickland.	P. W. Mason.	Col. T. L. Casey.
A. C. Burrill.	J. C. Faure.	S. C. Bishop.
J. H. Paine.	Harold Morrison.	D. L. Crawford.
D. C. Mote.	E. M. Schalek.	E. C. Cotton.
Prof. T. D. Jarvis.	R. A. Grizzell.	A. W. Baker.
Lawson Caesar.	Prof. R. W. Hegner.	A. B. Johnson.

The following have died during the year:

Dr. John B. Smith.	Prof. G. W. Taylor.
Prof. T. H. Montgomery, Jr.	E. L. Jenne.

The following resignations were presented, accepted by the Executive Committee, and the membership terminated:

Prof. C. E. Johnson.	E. J. Kraus.	H. G. Smith.
E. D. Keith.	Prof. F. H. Shoemaker.	E. S. Tucker.
G. Chagnon.		

A list of twenty names of persons who had been dropped for the non-payment of dues for two years or within one year of election to membership, was presented and adopted. This is in accordance with Sections 7 and 8 of the By-Laws.

The following twenty-four names were proposed for membership and elected by the Executive Committee at its meeting last evening:

C. J. Drake.	C. Carter.	H. Fox.
W. J. Phillips.	W. E. Snyder.	D. Milton Brumfiel.
A. G. Vestal.	C. E. Hood.	J. J. Culver.
M. M. Wells.	Margaret Washington.	C. H. Baldwin.
C. W. Creel.	F. W. L. Sladen.	P. S. Welch.
C. W. Long.	W. A. Ross.	E. M. R. Lamkey.
R. W. Leiby.	E. H. Gibson.	R. H. Wilson.
O. C. Bartlett.	C. R. Neillie.	W. J. Kostir.

The membership of the society as given in the last volume of the *Annals* contains two honorary fellows, 33 fellows, and 356 members, or a total of 391. There is reported above the death of one fellow and three members, the resignation of seven members, and the dropping of 20 others, which reduces the roll to 359. To this number should be added the 27 members elected in June and the 24 elected at this meeting, which makes the present total membership of the society 410.

#### TREASURER'S REPORT.

Cash on deposit in the First National Bank of Champaign, Illinois, December 19, 1911.....	\$ 696.60
Life Membership Fees deposited in Rothschild Bros. Savings Bank of Ithaca, New York, with interest at 4% to May 3, 1912.....	107.85
Cash received from Herbert Osborn, Managing Editor of the <i>Annals</i> ...	428.35
Cash collected as dues.....	812.56
	<hr/>
	\$2,045.36
Bills Paid.....	\$1,904.49
Life Membership Fees deposited in the Citizens Savings and Trust Co., of Cleveland, Ohio.....	100.00
Cash on deposit in the First National Bank of Champaign, Illinois, December 9, 1912.....	40.87
	<hr/>
	\$2,045.36

If the cash balance for 1912 is compared with that of 1911, it might seem that the financial condition of the society was not very good. The financial conditions on the contrary are the best for any year of which your treasurer has made any study of the accounts. He has paid for six numbers of the *Annals* in addition to handling the expense of mailing certificates of membership. Certificates have been sent to all persons included on the membership roll of the society and if there are any who have not received a certificate, the secretary should be notified. The net expense of issuing the six above mentioned numbers of the *Annals* alone was \$1731.93. The only outstanding account is for the December *Annals*, which had not been issued when the Treasurer's accounts were closed.

The Executive Committee appointed the Secretary-Treasurer and Professor J. H. Comstock at the Washington meeting a committee to deposit the fees of life members in a bank that they should consider safe at a good rate of interest. After considerable correspondence the Citizens Savings and Trust Company of Cleveland, Ohio, was selected and the funds deposited there May 3, 1912, where they will draw four per cent interest.

The following amendment to the Constitution submitted at the Boston meeting and voted upon at the Washington meeting was referred back to the Executive Committee by the latter meeting for further consideration:

Article IV. Section 3. The President shall represent the Society upon the Council of the American Association for the Advancement of Science until such time as the Society shall be qualified for representation by two councillors, in which case the second councillor shall be elected from the fellows by the Executive Committee.

To be amended to read:

Section 3. Councillors to the American Association. The President and the preceding Past-President shall represent the Society upon the Council of the American Association for the Advancement of Science.

The Executive Committee would recommend the following amendment:

Section 5. Councillors to the American Association: The President and the preceding Past-President shall represent the Society upon the council of the American Association of the Advancement of Science. In case of the death or resignation of either or both councillors, the vacancy shall be filled by the Executive Committee.

The Executive Committee took the following action: It was moved that the President and the preceding Past-President should represent the Society upon the Council of the American Association for the Advancement of Science during the year 1913.

Mr. Edward P. VanDuzee, Librarian of the Grosvenor Public Library, Buffalo, New York, who has made a special study of the Hemiptera, was by a unanimous vote of the Executive Committee elected a fellow of the society.

The following amendments and additions to the constitution are recommended:

Article V. Section 3. Election of Officers—All officers shall be elected by ballot at the annual meeting for the term of one year and shall be eligible for re-election. Their term of office shall commence with the first of June following their election.

To be amended to read as follows:

Article V. Section 3. Election of Officers—All officers shall be elected by ballot at the annual meeting for the term of one year and shall be eligible for re-election.

The following additional article to the Constitution, dealing with the publication and management of the Annals, to be number VII and the present article of that number, to be numbered VIII:

## ARTICLE VII.

SECTION 1. Publication—The official publication of the Society shall be known as the *Annals of the Entomological Society of America*. Each volume shall consist of four quarterly fascicles and the first fascicle of each volume shall contain the proceedings of the annual meeting.

SEC. 2. Editorial Board—The publication shall be under the charge of an Editorial Board consisting of ten members, one of whom shall be Managing Editor. The Managing Editor and his associates shall be responsible for the selection of the material to be published.

SEC. 3. Election of Editorial Board—The members of the Editorial Board shall be elected by the Executive Committee. Each member of this board, except the Managing Editor, shall serve for three years or until his successor has been elected, three members retiring annually.

SEC. 4. Report Managing Editor—The Managing Editor shall present a report at each annual meeting to the Executive Committee and the accounts of his office shall be reported upon by the Auditing Committee.

The Executive Committee took the following action regarding the mailing of the *Annals*, this action is to be printed on page three of the cover of each number of the magazine:

The Managing Editor is provided with the most recent address of all members on record in the Secretary's office for mailing the numbers of the *Annals* and hereafter members complaining of the non-receipt of numbers must present their complaint to the Secretary within four months from the date of the mailing of the issue. After that time the numbers will be furnished only at the regular published rate.

The Secretary reported the receipt from Jas. A. Barr, Manager of Conventions for the Panama-Pacific Universal Exposition of an embossed invitation issued by the president and directors of the Exposition, inviting the society to hold its meeting for 1915 on the Pacific coast. This meeting is to be held either in the Auditorium provided by the Exposition and located about half a mile from the Exposition entrance or at the University of California or at Stanford University. The Executive Committee offers the following recommendation: That the Executive Committee recommend to the Society that a special committee of five be appointed, to include two Pacific coast members, to consider and report at the next annual meeting concerning the desirability of holding a meeting in San Francisco in the summer of 1915.

On motion, the report of the Executive Committee was adopted.

The President named the following committee to consider the desirability of holding a meeting in San Francisco in 1915: E. P. Felt, New York State Entomologist, Albany, N. Y., Chairman; Vernon L. Kellogg, Stanford University, California; A. J. Cook, Horticultural Commission, Sacramento, California; W. M. Wheeler, Harvard University, Cambridge, Mass.; T. D. A. Cockerell, University of Colorado, Boulder, Colorado.

The committee appointed to draft resolutions on the death of Dr. Thomas Harison Montgomery, Jr., presented their report. It was ordered accepted and printed.

The following reports were presented:

REPORT OF THE MANAGING EDITOR OF THE ANNALS.

The report upon the progress of the Annals for the year 1912 might follow very closely the statement for the year previous but I feel that we are warranted in counting the past year as one of even more solid growth and that we may look with still greater confidence to future improvement.

In the matter of financial support there has been a distinct gain and the receipts of the editor which show a total of \$551.53 of which \$193.40 were for subscriptions, \$176.55 for back volumes sold and \$181.58 for reprints, etc., from authors indicates what may be expected as practically permanent revenue though we may not be equally successful every year in sale of back volumes.

The editor's expenses have been \$63.05 for engravings, \$35.20 for labor and stenographic service, \$24.93 for express and postage, and \$428.35 has been turned over to the treasurer.

In this connection it may be mentioned that a little effort by members in helping to place sets of the back volumes in libraries not yet supplied will assist materially in increasing income and giving support to enlargement and improvement. I am sure that such effort was helpful in the past year.

While we have not published quite as many pages of matter as for 1911 the volume will reach over 450 pages and includes a very creditable series of papers. The editor has in hand matter enough to practically fill a good March number and other desirable papers in sight. This with the prospect of a somewhat larger fund to devote to printing the coming year assures us I believe an excellent volume for 1913.

The Managing Editor desires to take this opportunity to express his gratitude for the many important aids rendered by the members of the Editorial Board in securing desirable contributions. He is especially indebted to Professors Folsom and MacGillivray for assistance in the issuing of the September number.

He appreciates particularly the cordial and hearty cooperation which has marked the relation of the members of the society to this enterprise.

Respectfully submitted,

HERBERT OSBORN,  
*Managing Editor.*

REPORT OF THE AUDITING COMMITTEE.

We, the undersigned, have this day examined the accounts of Alexander D. MacGillivray, Treasurer and Secretary of the Entomological Society of America for the year ending December 10, 1912, compared the vouchers therewith and found the same correct and properly cast.

Signed P. J. PARROTT,  
A. F. BURGESS,  
W. E. BRITTON.

## REPORT OF THE COMMITTEE ON NOMENCLATURE.

Your Committee on Nomenclature has to report that no questions have been submitted to it for consideration during the past year.

The discussion of the idea of *nomina conservanda* has been much in evidence of late, and the members of the committee have very decided personal opinions upon that subject. They realize, however, that any expression of their opinion as a committee would have no more weight than the sum total of their individual views, and therefore do not present any recommendation on the subject. Attention should be called to the point, however, that in the numerous lists of workers published, who have expressed themselves on the subject, many are morphologists only secondarily interested in questions of nomenclature, and rarely doing anything themselves in this subject. It would seem that the opinions of this class should hardly be given equal weight with those offered by persons constantly engaged in systematic work and who are therefore much more familiar with the difficulties constantly presenting themselves under either method.

It may also be appropriate here to call attention to earlier proposals nearly forty years ago, for the establishment of *nomina conservanda* which were favorably received at first, and to some extent adopted for a few years, but generally abandoned after a time. (Rules of Nomenclature as authorized to be published by the Entomological Club, A. A. A. S., July, 1877).

Your committee is inclined to regard the International Code as the one to accept in all cases, representing as it appears to, the formulated opinions of the largest body of scientific zoological workers in the world, and therefore presenting the largest number of supporters, to serve as a nucleus around which scientific opinion at large should concentrate and crystallize. They regret, however, that recent interpretations of the code seem to imply that a generic name accompanied by more or less of a description, but without reference either by name, figure, description or otherwise to any described and named species of animal, should be held as valid. They do not feel that this is any real use of a binomial nomenclature, and would welcome a ruling that any generic name to be applicable to any animal must be published in connection with some described or otherwise clearly indicated species, and that all generic names not so published should be regarded as *nomina nuda*.

Signed,

H. T. FERNALD,  
E. P. FELT,  
T. D. A. COCKERELL.

The report of the Committee on Nomenclature was accepted and ordered printed.

The following motion presented by Philip P. Calvert and seconded by F. L. Washburn was presented:

Moved that it is the sense of this meeting of the Entomological Society of America that the use of the International Code

of Nomenclature be recommended for the use of Entomologists generally. Carried.

The following report, of the delegates to the International Congress, in attendance at the Cleveland meeting, was presented:

REPORT OF DELEGATES TO THE INTERNATIONAL CONGRESS  
OF ENTOMOLOGY, AT OXFORD, ENGLAND.

While no official report has been called for from the delegates of the Society, and while from the fact that the delegate representation was not provided for at the Congress, such report may be unnecessary, it seems that some statement as to the work accomplished and scope of the Congress may be in order.

The delegates can all report a very enjoyable occasion with delightful opportunities for acquaintance with Entomologists from various countries who were at the Second International Congress. They can also report with much appreciation the advantages of the place of meeting, and the enthusiasm with which the Congress was entertained by the local Entomologists.

In the various sectional meetings there were presented a large number of creditable papers and these provoked profitable discussions. The sections in Taxonomy and Economic Entomology were particularly well attended and successful. The questions upon nomenclature introduced by the resolution from the Entomological Society of London, were the subject of much discussion, and resulted in the provision for an international committee to consider the particulars of nomenclature. The details for this arrangement will doubtless in time come to the Society with a request for the designation of a member of the Society to serve on such committee.

The constitution of the Congress appears to your delegates to be faulty in that it does not provide delegate representation from the different countries or from National Societies, and until such provision is made it appears to us that the results of action in the Congress must fail to secure any general acceptance.

The Congress, as at present constituted, is composed simply of members who may pay the fee, and such membership is open to all persons whether entomologists or not, so it follows that any individual subscribing the membership fee has just as much weight in voting as a delegate or representative from a country, representing hundreds of society members. Further, the constitution of the Executive Committee, which seems not to be subject to election by the Congress at large, as well as the election of officers and decision as to place of meeting, are entirely in the hands of the Executive Committee of four members.

While the arrangement for the committee on nomenclature may prove successful, there are certainly many other questions of international importance, which should be considered by such a Congress, and we believe that it should be urged upon the Executive Committee

that some provision be made for delegate representation from different countries, and from different Entomological Societies, and that a definite constitution be prepared and submitted to Entomological Societies of different countries, with carefully prepared plans for the election of officers, the formation of the Executive Committee and other details of organization not yet provided for.

As delegates we wish to emphasize the value of the social features of the Congress, and to express the belief that such meetings will be of great ultimate advantage to entomological science in bringing together the entomological workers of different countries. We wish also to express our appreciation of the cordiality of the local representatives.

In accordance with directions from the Society we presented the invitation to the Congress to meet in America for its next session, but the question of place of meeting, had evidently been determined by the Executive Committee, and while our presentation of the case was listened to, there was evidently no chance to secure a favorable decision for the next Congress. We were assured, however, that the Congress would hope to meet in America in the near future, and it seemed well understood that an invitation to meet in America in 1918, would receive cordial response and favorable action.

The next Congress is to be held in Vienna in 1915, under the presidency of Dr. Handlirsch.

Signed                    HERBERT OSBORN,        STEPHEN A. FORBES,  
                                  PHILIP P. CALVERT,     L. O. HOWARD.

#### REPORT OF COMMITTEE ON NOMINATIONS.

Your committee begs leave to report the following names as nominees for the respective offices for 1913:

#### OFFICERS.

President: C. J. S. Bethune, Ontario Agricultural College, Guelph, Ontario.  
First Vice-President: Philip P. Calvert, University of Pennsylvania, Philadelphia, Pennsylvania.  
Second Vice-President: William M. Marshall, University of Wisconsin, Madison, Wisconsin.  
Secretary-Treasurer: Alexander D. MacGillivray, University of Illinois, Urbana, Illinois.

#### ADDITIONAL MEMBERS OF EXECUTIVE COMMITTEE.

Herbert Osborn, Ohio State University, Columbus, Ohio.  
C. P. Gillette, Colorado Agricultural Experiment Station, Fort Collins, Colorado.  
Vernon L. Kellogg, Leland Stanford Jr. University, Stanford University, California.  
James G. Needham, Cornell University, Ithaca, New York.  
C. T. Brues, Harvard University, Cambridge, Massachusetts.  
Nathan Banks, United States National Museum, Washington, D. C.

#### MEMBER OF COMMITTEE ON NOMENCLATURE.

E. P. Felt, New York State Entomologist, Albany, New York.

(Signed)                    HERBERT OSBORN,  
                                  R. A. COOLEY,  
                                  CORNELIUS BETTEN.



On motion, the secretary was instructed to cast a single ballot for the officers named. They were declared elected.

REPORT OF THE COMMITTEE ON RESOLUTIONS.

*Resolved*, That we express to the authorities of the Western Reserve University and of the Normal School our deep appreciation of the courtesies extended this society;

*Resolved*, That the thanks of this Society be extended to Mr. E. H. Edwards for his generous assistance in arranging rooms for our use at the Normal School as well as his personal help toward the success of this meeting;

*Resolved*, That we commend the Editorial Management of the Annals of this Society and hereby recognize the value of Professor Osborn's painstaking work in furthering the interests of this publication.

Signed      S. J. HUNTER,  
                  W. A. RILEY,  
                  L. B. WALTON.

On motion the report was adopted.

Upon the recommendation of the Committee on Resolutions of and by action of the Society at the Washington meeting, the following committee on types was appointed. Their report follows:

REPORT OF THE COMMITTEE ON ENTOMOLOGICAL TYPES.

Your Committee, appointed to report on Entomological Types, submits the following:

**Location of Types.** According to reports kindly furnished by the Directors or Curators, some of the larger museums of this country contain types as follows:

U. S. National Museum. About 16,000.

Museum of Comparative Zoology. Over 10,000.

Philadelphia Academy and American Entomological Society. About 7,100.

Dr. Skinner states that this includes only holotypes and lectotypes. It is believed that the combined Philadelphia collections probably contain 35,000 "types", counting all the cotypical, paratypical and typical specimens.

Carnegie Museum, including Dr. Holland's collection (on deposit). About 4,000.

The number owned by the Boston Society of Natural History (several hundreds, at least), American Museum of Natural History and Museum of the Brooklyn Institute cannot be given at the present moment, but will be ascertained later. A list of the types of insects, other than Lepidoptera and Formicoidea, in the American Museum has just been published (Bull. Amer. Mus. Nat. Hist. XXXI, pp. 353-379). The Milwaukee Public Museum has 71 types. Doubtless the British Museum has more insect types than any other museum in

the world, but there is no catalogue and the number is not known, even approximately. The New York State Museum at Albany possesses a large number of types under the care of the State Entomologist. A catalogue was published in *N. Y. Museum Bulletin* 141 (1909) pp. 119-122, but Dr. Felt informs me that probably about 700 Cecidomyiidae are to be added. Stanford University has about 500 types, the majority Mallophaga.\*

There are some very large private collections, such as those of Dr. William Barnes at Decatur, Illinois, (890 types), Dr. Nathan Banks at East Falls Church, Va., (about 1500 types and about 300 cotypes or paratypes) and Col. Thos. L. Casey. In the above estimates cotypes or paratypes are in nearly every case reckoned as types.

**Opinions on the Location of Types.** We have sought to ascertain the opinions of representative entomologists regarding the location of types, and cite the following as examples:

"We believe that privately owned types should eventually go to some good museum."—H. Skinner.

"I consider it unwise to make any suggestion as to restricting types to certain institutions."—S. Henshaw.

"I believe that it should be the policy of authors to place their types where they will be cared for in the future."—W. J. Holland. (See also *The Conservation of Types*, First International Entomological Congress, p. 366, where six museums are named as the only ones in the United States to which types should be consigned).

"I do not believe that types should remain permanently in private collections."—W. M. Wheeler.

"I do not see how any fixed rules regarding the distribution of types can be made, nor can we prohibit them from being private property. With many a zoologist his collection and books are his only assets, and while he is working they are probably doing as much good in his own collection as in a public museum. When I am through with my collection I want it to go into the hands of a dipterist."—C. W. Johnson.

"It would be of course a very good thing to have the types in a limited number of public institutions, or still better in one only, but I am afraid this ideal condition will never be reached. In regard to a privately owned type, I am of the opinion that as soon as a new species is described the type becomes public property, and the author, if he keeps it in his own collection, should take great pains to keep the type safe and in good condition, and provide sooner or later for a resting place in a public institution."—Chas. Schaeffer.

"Personally I am inclined to the view, that types ought to be restricted to as few institutions as possible. As to the number of these, or how they should be selected, I have no opinion."—S. Graenicher.

"We deposit all particularly perishable types (such as pinned insects) in the U. S. National Museum."—A. G. Ruthven, Head Curator, University of Michigan Museum.

\* Since the report was read, the University of Kansas has reported the possession of 897 types and 36 cotypes, etc. The University of Kansas does not loan types.

"It seems to me that the committee ought to strongly urge the designation of only one specimen as type, and that all such types should be put in institutions easy of access, having fire-proof buildings and careful curators."—F. E. Lutz, American Museum of Natural History.

"I think that insect types ought to be especially available to the men most active in working with the groups represented by them. If these men are in or near the greater museums, then the types should be in these museums. My belief is that the types should be where they can be and will be most effectively used."—V. L. Kellogg.

"Respecting types in general, I believe that they should be most carefully cherished and available for study by any competent party. The ideal arrangement would be to deposit all such types at some central point, for example, the National Museum, but as matters are now I fear this is impractical. Even were I personally willing to deposit all my types in the National Museum, I do not believe that the parties responsible for the integrity of the Museum and its collections would for a moment consider such a proposition. In any event, I should not care to part with types until certain that my studies in the group were completed. You can readily understand that in many cases it would be extremely difficult to fix any such date. It seems to me very desirable to segregate, so far as practical, the types of any one group; for example, the type of a single species of Coleoptera might much better be deposited in a large collection where there are numerous types of allied forms, than retained in some other collection possibly equally extensive, with practically no other type material in that order. My reason for suggesting this is that it is so easy by scattering types in widely separated groups for them to be lost unless they are in some collection known to be valuable because of the large amount of such material it may contain. It should at least be possible to deposit co-types with workers in special groups or in our larger collections, for example, those of the National Museum."—E. P. Felt.

"In general I do not approve of types being held by private individuals where the collection is not properly looked after and liable to destruction at any time (*vide* the French collection, which is now *totally* destroyed by Dermestes, types and all). Of course in Dr. Barnes' case it is different. His collection has assumed museum proportions just as the Walsingham collection in England."—J. McDunnough.

**Location of Types in the Collections.** In nearly all collections, so far as we have ascertained, the types are placed in the systematic series. At the British Museum certain special collections, as the Banks collection (types of Fabricius) and the Wollaston collection (Coleoptera from the Atlantic Islands) are kept separate; while other types are in the accession drawers or in special cabinets, awaiting the rearrangement of the groups to which they belong. At the Museum of the University of Michigan all types (including cotypes and paratypes) are kept together in a fire-proof case on the first floor of the building. They are, however, not very numerous. At the Carnegie Museum the Ulke collection of Coleoptera remains in the boxes exactly as received from Mr. Ulke, and the Smith collection of Brazilian bees studied by Cockerell

is also still as received from that author. At the Museum of Comparative Zoology some recent accessions have not yet been placed in the series.

It is the nearly universal policy not to separate the types from the rest of the collection.

**Labelling of Types.** It is usual to label the types, and in no case is it the regular policy not to do so. In some of the older collections the types are not, or not all marked. In several instances the labelling of the types has been done by curators after the collections had passed out of the hands of the describers. This has of course been necessary, but it has not always been carefully done, and we know of cases, in large museums, where so-called types are either not of the same species, or from the same locality, as the specimens originally described under the name.

Red is the favorite color for type labels, but great diversity prevails. Some museums have different labels for types, cotypes, etc. A sheet of type-labels is appended for inspection at the meeting. The U. S. National Museum has special red labels for slides and alcoholic specimens.

**Catalogues of Types.** Some institutions, as the American Museum of Natural History and the New York State Museum, have published partial or complete catalogues of their types. In many, such as the U. S. National Museum, a manuscript catalogue is kept, and each type receives a number. Some institutions have no catalogues; several report one in progress. At the British Museum the types are not catalogued, except in the published catalogues of the Museum, such as that of Sir G. F. Hampson, which will when complete cite all the types of moths.

**Loaning Types.** The following replies have been received in answer to our questions:

"It has never been legal for a type to leave the building, and the rule has been invariably enforced."—G. Meade-Waldo, British Museum.

"Recently the rule against the loaning of holotypes has been enforced. Cotypes or paratypes are loaned when we have the type or others of the same sort. If, however, the cotype or paratype is the only type specimen we have it is treated as a holotype, i. e., not loaned."—J. C. Crawford, U. S. National Museum.

"The American Entomological Society does not loan unique types." The Philadelphia Academy treats each case on its merits.—H. Skinner.

"All M. C. Z. rules are elastic, but we do not loan types except there is especial reason for so doing."—S. Henshaw, Museum of Comparative Zoology.

"The Society has loaned types; whether it will continue to do so is a question."—C. W. Johnson, Boston Society of Natural History.

"There is a rule against sending types out of the Museum, though the Director has loaned his private types."—Hugo Kahl, Carnegie Museum.

"It is against our rules to loan types."—C. Schaeffer, Museum of Brooklyn Institute.

"We do not make a practice of loaning type material."—E. P. Felt, New York State Museum.

"We do not loan holotypes. We do loan cotypes and paratypes."—V. L. Kellogg, Stanford University.

"We have a rule against loaning types. When, however, all the following conditions exist we do occasionally send them out. The borrower must be a trustworthy man who cannot conveniently get to New York. The specimens must be of such a character that they would not be likely to be injured in transportation, and there must be a series, all of which are designated "type" by the author. The latter seems to be a bad practice, but when there is such a series and the other conditions are met we have occasionally sent out one or two specimens."—F. E. Lutz, American Museum of Natural History.

"I think the question of loaning types is a delicate one. I believe in institutions loaning them to thoroughly accredited persons and under very stringent conditions."—W. M. Wheeler.

The Milwaukee Public Museum has no rules governing the loan of types.

**Fireproof Buildings.** Experience has shown that so-called fireproof buildings are sometimes destroyed by fire. Nevertheless, the following information is of value. The new National Museum "is absolutely fireproof, the only wood in construction being a skin floor on the top floor and wooden window casing on this same floor. The doors are of steel. The only thing that would burn is the exhibits, and, in the case of insects, we store them in steel cases, making it impossible for them to catch fire if anything exposed should burn." It should be said, however, that very large alcoholic collections are kept in the basement. At the British Museum the collections of fishes and reptiles (except the public exhibits) are in a separate building, on account of the danger from fire. It is hardly conceivable that a fire among the alcoholics in the basement of the U. S. Museum would effect the insects, which are on an upper floor.

The American Museum of Natural History "is as completely fireproof as it is possible to be made."

"The collections (of the New York State Museum) at the present time are not in a fireproof building, though we expect to move within a few months into a thoroughly modern fireproof structure."

"The Museum of the Brooklyn Institute is considered fireproof."

"The Carnegie Museum building is fireproof."

The Museum of Comparative Zoology building was considered fireproof when examined by insurance experts.

The Philadelphia Academy building "is built of brick, steel and concrete; the upright steel girders are covered with terra cotta and then cemented. The main rooms and floors are all separated by automatic fire doors. The floors are concrete with no wood."

## RECOMMENDATIONS.

**Location of Types.** It is necessary for the progress of entomology that specialists should frequently have in their possession collections containing many types, and experience shows that so long as these collections are in use the types are reasonably safe and well cared for. Ultimately, however, these types should find a place in some large public museum, where they will be preserved for the use of posterity. If entomologists are expected to make arrangements looking toward the placing of their types in public museums, they have the right to demand that these museums shall be made fully competent to take care of them. Not only must the buildings be practically fireproof, and the cabinets adequate, but there must be a staff large enough to take care of the specimens and keep them in order. Types should never be deposited where a continuous succession of competent curators (entomologists) cannot be depended upon.

**Location of Cotypes and Paratypes.** New species of insects are frequently described from considerable series of specimens, designated cotypes or paratypes. Authors would probably be glad to distribute some of these among the principal museums or collections, if convenient arrangements existed for doing so. Such distribution would greatly facilitate entomological work, and we suggest the desirability of considering whether some distributing center cannot be organized.

**Location of Types in Collections.** We believe that types are best kept in the systematic series, where they can readily be found and compared with their allies.

**Labelling of Types.** It is highly desirable that uniform labels should be used for types. Among those submitted for examination, the circular labels with colored margins, from the British Museum, seem to have a sufficient degree of distinctness to enable them to be readily seen, without the rather offensive conspicuousness of some other labels. There should, however, be a place for the type number.

**Cataloguing Types.** Every museum should catalogue its types, giving each a number. It is very desirable to publish the catalogue, with supplements from time to time. We also suggest that lists of the types received during the year would be useful additions to museum reports, and might well replace some of the worthless information which these usually contain.

**Loaning Types.** We are of the opinion that holotypes, or specimens designated as *the type* should under no circumstances be loaned; but cotype or paratype material should be loaned under proper restrictions.

**Permanent Committee.** We suggest that the type committee be made permanent, with changing membership, like the committee on nomenclature, and that its members be requested to examine and report on museums and collections as opportunity offers.

Signed

T. D. A. COCKERELL,  
L. O. HOWARD,  
HENRY SKINNER.

On motion, the report was ordered accepted and printed, and the committee continued for another year.

The following papers were then read:

*Edith M. Patch and William C. Woods, Maine Agricultural Experiment Station: A Study in Antennal Variation.* Read by title.

*Alex. D. MacGillivray, University of Illinois: Propharynx and Hypopharynx.*

The pharynx after entering the occipital foramen makes a distinct bend toward the mouth. In the region of the clypeus, it divides transversely, one-half passes to the clypeo-labral side, the other half to the labial side of the mouth, while folds extend along each lateral margin and unite with the mandibles and maxillæ. The name of propharynx is proposed for the portion lying adjacent to the clypeo-labral part of the mouth and hypopharynx is used for the portion lining the labial portion. The propharynx consists of three parts: frontal lobe, epipharynx, and fulcrum. The frontal lobe is usually wanting in sucking insects, the epipharynx is modified into a tongue or piercing organ and the fulcrum into a cuticular supporting plate. In the muscids the epipharynx and fulcrum are located outside of the mouth, the proximal end of the fulcrum is attached to the distal margin of the labrum. The hypopharynx also consists of three parts; lingua, superlingua, and pharyngeal sclerites.

*F. L. Washburn, State Entomologist, Minnesota: A few Experiments in Photographing Living Insects.*

*Thomas J. Headlee, New Jersey Agricultural Experiment Station: Some Facts Regarding the Influence of Temperature and Moisture changes on the Rate of Insect Metabolism.*

While connected with the Kansas State Experiment Station at Manhattan, the writer found by subsection of different groups of the Southern Grain Louse (*Toxoptera graminum* Rodani) to various constant temperatures under constant atmospheric moisture conditions and other groups to various constant percentages of relative humidity under constant temperature conditions: (1) that the rate of increase in metabolism for each 10°F. increase in temperature, starting at 58°F., decreases as the optimum temperature is approached, and that while the metabolism of degeneration becomes more rapid after the optimum is passed the rate of growth is retarded; (2) that a variation of from 60 to 62% in atmospheric moisture does not effect the rate of metabolism when the creatures have an abundant supply of succulent food.

Similar tests of the effect of temperature on the rate of metabolism in *Lysiphlebus tritici* Ashm, and of the effect of temperature and moisture on the rate of metabolism of the Chinch Bug (*Blissus leucopterus* Say) infected and uninfected by the chinch-bug fungus (*Sporotrichum globuliferum* Speng.) gave similar results.

*J. T. Abbott, Washington University: The Strigil in Corixidæ and its Probable Function.* Read by Title.

*Edna Mosher, University of Illinois: The Anatomy of Some Lepidopterous Pupæ.* (Presented by Mr. Alvah Peterson).

Figures of pupæ of three species were shown and described. *Sthenopis thule*, *Archips argyrosbila*, and *Lymantria leucostigma*. Figures of the pupal cases of each of these species were shown, also figures of the pupæ, with the cases dissected away so as to show the parts underneath. Considerable difficulty has been encountered in homologizing the pupal structures from the external appearance particularly in the case of the fixed parts of the head and the appendages of the head and thorax. The leg cases were shown to be a frequent source of error. Instead of showing externally only the cases for the tibiæ and tarsi, as Scudder claims is the case in the butterflies, certain forms show the femur cases and either the whole or part of the coxal cases in certain pairs of legs. What Packard calls the paraclypeal pieces, were shown in these forms to contain functionless mandibles which had their distal margins toothed in the case of *Lymantria*.

This detailed anatomical study is to be made the basis for a phylogenetic and taxonomic arrangement of the Lepidoptera based on an examination of the characters of the pupæ.

*Charles K. Brann, Ohio State University: Some Anatomical Studies of Stomoxys calcitrans Lin.* (Introduced by Professor Herbert Osborn). Printed in part in December Annals. Part II will appear in June Annals.

*S. W. Bilsing, Ohio State University: Observations on the Food of Spiders.* (Introduced by Professor Herbert Osborn)

Spiders are known to feed upon insects but exact records of kind and quantity of food for particular species are very meager. Extended observations and records were made during the summer and fall of 1912 and data from some of these are presented. As an example of the records given, grasshoppers constituted 39% of the food of *Miranda aurantia*, 59% of the food of *Agalena navia* and 22% of the food of *Aranea trifolium* during the period under observation.

*Herbert Osborn, Ohio State University: Observations on Insects of a Lake Beach.*

The Insect fauna of the Cedar Point Beach of Lake Erie is discussed with reference to its derivation and adaptation for the conditions presented. The insect drift, the migrant and the resident members of the association are separated and records of species in each group given.

*C. H. Tyler-Townsend, Government Entomologist of Peru: The Species-Status and the Species-Concept.* Read by Title.

*C. H. Tyler-Townsend, Government Entomologist of Peru: A New Application of Taxonomic Principles.* Read by Title.



A smoker was held in a grill room of the Hotel Euclid after the annual public address, by a number of the entomologists in attendance at the meetings.

The annual public address of the Society was given on Wednesday evening, January 1st in the Auditorium of the Normal School by Dr. Philip P. Calvert, University of Pennsylvania.

The following exhibits were shown:

R. D. Glasgow, University of Illinois.—Apparatus for orienting insects under the microscope.

F. E. Lutz, American Museum Natural History.—Professor T. H. Morgan's mutants of *Drosophila ampelophila*.

Herbert Osborn, Ohio State University.—Some examples of Cicadidæ, especially the Ohio species of the genus *Cicada*.

N. L. Partridge, University of Illinois.—Pupal wings of *Attacus cecropia*.

Victor E. Shelford, University of Chicago.—Experimental modification of the colors and color patterns of *Cicindela*.

Alex. D. MacGillivray, University of Illinois.—The propharynx and hypopharynx of a cockroach, a locust, and a hornet.

F. L. Washburn, State Entomologist of Minnesota.—Snap shots of living insects in the field.

Anna H. Morgan, Mt. Holyoke College.—Drawings of the eggs of May-flies.

On motion, the Society adjourned to meet in one year with the American Association for the Advancement of Science at Atlanta, Georgia.

ALEX. D. MACGILLIVRAY,  
*Secretary.*



## NOTICE TO MEMBERS AND CONTRIBUTORS.

---

The Annals of the Entomological Society of America, published by the Society quarterly, includes the Proceedings of the Annual meetings and such papers as may be selected by the Editorial Board.

Papers may be submitted to any member of the Editorial Board and should be as nearly as possible in the form desired as final, preferably typewritten, and illustrations must be finished complete ready for reproduction. Plates must not exceed 5x7 inches unless intended to fold. In general, papers to be accepted must be original, complete and previously unpublished and, except in connection with the proceedings, it will not be the policy to publish preliminary announcements or notes. Authors will be allowed fifty reprints gratis and additional copies at cost to the Society.

The Managing Editor is provided with the most recent address of all members on record in the Secretary's office for mailing the numbers of the Annals and hereafter members complaining of the non-receipt of numbers must present their complaint to the Secretary within four months from the date of the mailing of the issue. After that time the numbers will be furnished only at the regular published rate.

Requests for information as to membership and the annual subscription and dues of members may be sent to the Secretary-Treasurer, A. D. MacGillivray, 603 Michigan Ave., Urbana, Ill.

Communications relating to the ANNALS, and all orders for separate copies or reprints should be addressed to the Managing Editor or to

ANNALS OF THE ENTOMOLOGICAL SOCIETY OF AMERICA,  
Biological Building, State Univ., Columbus, Ohio.

## CONTENTS OF THIS NUMBER.

---

CALVERT, P. P.—An Entomologist in Costa Rica.....	1
ZETEK, JAMES.—Determining the Flight of Mosquitos.	5
VAN DUZEE, M. C.—A Revision of the North American Species of the Dipterous Genus <i>Neurigona</i> . ( <i>Dolichopodidæ</i> .) .....	22
BETTEN, CORNELIUS.—An Interesting Feature in the Venation of <i>Helicopsyche</i> , the <i>Molannidae</i> , and the <i>Leptoceridae</i> .....	65
FUNKHOUSER, W. D.—Homologies of the Wing Veins of the <i>Membracidae</i> .....	74
METCALF, Z. P.—The Wing Venation of the <i>Jassidæ</i> ..	103
TOWER, D. G.—A New Hymenopterous Parasite on <i>Aspidiotus Perniciosus</i> Comst.....	125
Entomological Society of America .....	127

---

The regular annual subscription price for the ANNALS is in the United States, Cuba, Porto Rico, Hawaii and Mexico, \$3.00; Canada, \$3.50; other countries, \$4.00. Checks, drafts or money orders should be drawn payable to ANNALS ENTOMOLOGICAL SOCIETY OF AMERICA, and addressed to Biological Building, State Univ., Columbus, Ohio, U. S. A.

ANNALS  
OF  
The Entomological Society of America

---

JUNE, 1913

---

EDITORIAL BOARD

J. H. COMSTOCK,  
ITHACA, N. Y.

L. O. HOWARD,  
WASHINGTON, D. C.

C. J. S. BETHUNE,  
GUELPH, ONTARIO, CANADA.

W. M. WHEELER,  
BOSTON, MASS.

C. W. JOHNSON,  
BOSTON, MASS.

P. P. CALVERT,  
PHILADELPHIA, PA.

V. L. KELLOGG,  
STANFORD UNIV., CAL.

J. W. FOLSOM,  
URBANA, ILLS.

HERBERT OSBORN, Managing Editor,  
COLUMBUS, OHIO.

---

PUBLISHED QUARTERLY BY THE SOCIETY  
COLUMBUS, OHIO

# The Entomological Society of America.

FOUNDED 1906.

## OFFICERS 1913.

*President*—C. J. S. BETHUNE ..... Guelph, Ont., Canada  
*First Vice-President*—P. P. CALVERT ..... Philadelphia, Pennsylvania  
*Second Vice-President*—WM. M. MARSHALL ..... Madison, Wisconsin  
*Secretary-Treasurer*—A. D. MACGILLIVRAY ..... Urbana, Illinois  
*Executive Committee*—THE OFFICERS, and HERBERT OSBORN, C. P. GILLETTE,  
V. L. KELLOGG, J. G. NEEDHAM, C. T. BRUES, NATHAN BANKS.  
*Committee on Nomenclature*—H. T. FERNALD, E. P. FELT, T. D. A. COCKERELL.

## Price List of Publications.

Annals, Vols. I, II, III, IV and V, complete, each.....	\$3.00
Annals, Separate Parts except as below, each.....	1.00
Annals, Vols. I and II, Part 3, each.....	.50
Annals, Vol. IV, Part IV, each.....	1.50

## REPRINTS FROM VOLUME I.

Proceedings of first three meetings; Constitution, By-Laws and List of Members.....	.25
WHEELER, WM. M.—Polymorphism of Ants.....	.30
OSBORN, HERBERT—The Habits of Insects as a Factor in Classification.....	.20
SEVERIN, H. H. AND SEVERIN, H. C.—Anatomical and Histological Studies of the Female Reproductive Organs of the American-Saw Fly, <i>Cimbex Americana</i> , Leach.....	.25
FELT, E. P.—Some Problems in Nomenclature.....	.10
HAMMAR, A. G.—On the Nervous System of the Larva of <i>Corydalis cornuta</i> L.....	.25
BRADLEY, J. C.—A case of Gregarious Sleeping Habits among Aculeate Hymenoptera.....	.10
DAVIS, J. J.—Notes on the Life History of the Leafy Dimorph of the Boxelder Aphid, <i>Chaitophorus negundinis</i> Thos.....	.10
HAMBLETON, J. C.—The Genus <i>Corizus</i> , with a Review of the North and Middle American Species.....	.25
GIRAULT, A. A.—Biological Notes on Colorado Potato Beetle.....	.25
GIRAULT, A. A.—A Monographic Catalogue of the Mymarid Genus <i>Alaptus</i> ..	.25
SEVERIN, H. H. and SEVERIN, H. C.—Internal Organs of Reproduction of Male Saw-fly.....	.15
SMITH, C. P.—A Preliminary Study of the Araneæ Theraphosæ of California..	.75
DAVIS, J. J.—Studies on Aphididæ.....	.20
RILEY, W. A.—Muscle Attachment of Insects.....	.15
NEEDHAM, J. C.—Critical Notes on the Classification of the Corduliinæ (Odonata).....	.15
HOWARD, L. O.—A Key to the Species of <i>Prospaltella</i> with Table of Hosts and Descriptions of Four New Species.....	.15
HOOD, J. D.—Two New Species of <i>Idolothrips</i> .....	.10

Address

ANNALS ENTOMOLOGICAL SOCIETY OF AMERICA,  
Biological Building, State Univ., Columbus, Ohio.

ANNALS  
OF  
The Entomological Society of America

---

Volume VI

JUNE, 1913

Number 2

---

A REVISION OF THE NORTH AMERICAN SPECIES OF  
MEGASTIGMUS DALMAN.

C. R. CROSBY.

The genus *Megastigmus* was founded by Dalman in 1820 (Svensk. Vet.-Akad. Handl. XLI, p. 178) as a subgenus of *Torymus* to contain the three species: *bipunctatus* Swederus, *collaris* and *chloronotus*. *Collaris* was described by Boheman after Dalman's death in 1833 (Svensk. Vet.-Akad. Handl., p. 332). *Chloronotus* was never described but Boheman placed it under *Torymus* (*Megastigmus*) *dorsalis* Fabricius (l. c. p. 334). The type of the genus therefore cannot be *M. dorsalis* as stated by Ashmead (Chalcis-flies, p. 380, 1904) but must be *M. bipunctatus* Swederus since that is the only one of the three species cited by Dalman which was described at that time.

*Megastigmus* is distinguished from other *Torymidæ* occurring in North America by the enlarged and pigmented stigmal club and by the presence of a well developed basal vein. The posterior tibiæ have two well developed apical spurs as in other *Torymidæ*; Ashmead's table to the subfamilies (Chalcis-flies, p. 236, 1904) is in error on this point, and this mistake has been copied by Schmiedeknecht in *Genera Insectorum*, fasc. 57, p. 118, 1909. The mandibles have three teeth. The scutellum has a fine cross furrow as in *Syntomaspis*. The ovipositor, except in two species, is longer than the abdomen, slender and gently curved upward. The coloration in the American forms is never metallic; usually yellowish brown or opaque blackish.

As far as known the larvæ of all our species live in the seeds of plants.

## FEMALES.

## TABLE OF SPECIES.

1. Ovipositor not longer than abdomen.....	2
Ovipositor longer than abdomen.....	3
2. Stigmal club oval.....	<i>brevicaudis</i>
Stigmal club elongate.....	<i>physocarpi</i>
3. Front wings marked with a brownish spot adjoining the hind margin of the submarginal vein.....	<i>albifrons</i>
Front wing not so marked.....	4
4. Stigma surrounded by a clouded area.....	<i>nigrovariegatus</i>
Stigma not surrounded by a clouded area.....	5
5. Mesonotum black with an oblong reddish orange area covering the posterior half of the middle lobe, the inner angles of the scapulæ and axillæ and all of scutellum.....	<i>pinus</i>
Not so marked.....	6
6. Black species.....	7
Yellow species.....	8
7. Pronotum with two yellow spots.....	<i>tsugæ</i>
Pronotum black without yellow spots.....	<i>lasiocarpæ</i>
8. Axillæ yellow; stigmal vein as long as the club is wide.....	<i>spermotrophus</i>
Axillæ black except inner angle; stigmal vein shorter than the width of the club.....	<i>aculeatus</i>

*M. flavipes* Ash. (1886) was described from males only.

**Megastigmus brevicaudis** Ratzeburg.

*Megastigmus brevicaudis* Ratzeburg. Ichneum. Forstinsect., III, p. 225. 1852.

*Megastigmus brevicaudis* Rodzianko. Comment. Tonym., pp. 608-611. 1908.

*Megastigmus brevicaudis* Crosby. Cornell Exp. Sta. Bull., 265, pp. 375-377, Figs. 77-79. 1909.

*Megastigmus brevicaudis* Rohwer. U. S. Bur. Ent., Tech. Bull. 20, pt. VI, p. 159. 1913.

Female.—Length, 2.4 mm.; abdomen, 1 mm.; ovipositor, .7 mm.

Face, cheeks and a partial ring around eye yellow. Vertex and occiput very dark brown, nearly black. Vertex finely transversely rugulose.

Prothorax yellowish, indistinctly marked with dusky on the sides. Rest of the thorax nearly black with a dull yellowish tinge showing through on the scapulæ and scutellum. Antennæ brownish yellow, scape and pedicel black above and yellow beneath. Anterior coxæ yellow; middle and hind coxæ brownish; rest of legs light yellowish. Wings hyaline; stigmal club not surrounded by a clouded area.

Abdomen brownish on the sides, nearly black above. Ovipositor short, dark brown.

Described from 1 ♀, Ratzeburg's type. I have three females reared by W. N. Rodzianko from the seeds of *Sorbus aucuparia* at Poltawa, Russia, which agree very closely with the type.

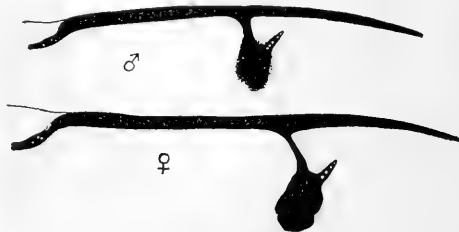

Fig. 1. *Megastigmus brevicaudis*.



Through the kindness of Mr. A. G. Hammar I received some Sorbus berries from Sweden from which 5 females were reared. In these specimens the head is black with the face dark honey-yellow. Prothorax honey-yellow, rest of thorax black. Antennæ very much darker than in the type. Abdomen black with brownish bars on the sides. Rodzianko states that he has never been able to rear the male.

I have reared this species abundantly from the seeds of Sorbus in New York State. The American specimens are slightly smaller than those from Europe and vary greatly in color, but I have been unable to find any constant character by which they may be separated. The darker individuals are very close to the typical form. A large proportion of the specimens are of uniform brownish yellow. The legs are light yellow and the antennæ and ovipositor are brownish. Between these and the typical form all gradations occur.

Male.—Length, 1.7 to 2.1 mm.; abdomen, .7 to .8 mm. All the males reared are much darker than the females. The face and cheeks are yellow; the legs dull yellowish and the antennæ more yellowish than in female. Head and thorax black except a small spot on each side between the ocelli and the eyes and an area on the lateral aspect of the prothorax, which are brownish yellow. Stigmal club surrounded by a very narrow clouded area.

Abdomen compressed, seen from the side, elongate triangular, rounded behind, brown-black above and yellowish brown beneath and at apex.

The larva is white, and its mandibles have four teeth on the inner margin.

In addition to rearing the adult insect at Ithaca, infested berries of the Mountain Ash have been found at Weedsport, Jamesville and Wayland, N. Y.

In the National Museum collection is a female specimen from Mt. Washington bearing Ashmead's manuscript name *Megastigmus slossonæ* which agrees exactly with the lighter specimens reared from Sorbus seeds from New York State. In the National Museum there is also a very dark ♀ from Oswego, N. Y., 1 July, 1897.

As suggested by Mayr. (Verh. zool.-bot. Ges. Wien, XXIV, p. 139. 1874) this species may be the same as *M. bipunctatus* Boheman.

**Megastigmus physocarpi** n. sp.

Female.—Length, 1.8 mm.; abdomen, .8 mm.; ovipositor, .8 mm.

Head and prothorax yellow, rest of thorax and abdomen brownish yellow, the latter much darker. Head and prothorax delicately transversely rugulose; mesothorax with a more pronounced sculpture; propodeum closely but distinctly reticulate, a distinct median carina present. A brownish line connects the ocelli.

Scape yellow; pedicel dusky above, yellow beneath, rest of antennæ dusky. Legs including coxæ light yellow. Wings hyaline. The stigmal club is narrow and elongate; not surrounded by a clouded area.

Most of the females agree with this description but there are three specimens in which the ovipositor is not over half the length of the abdomen. In these specimens the prothorax has a median black stripe narrower behind and the rest of the thoracic dorsum is black except the scapulæ and the posterior part of the propodeum.

Male.—Length, 1.6–1.9 mm.; abdomen, .7 mm.

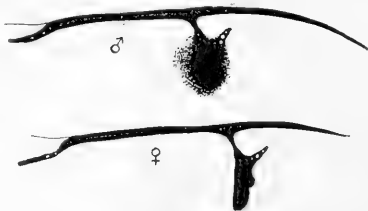

Fig. 2. *Megastigmus physocarpi*.

Similar to the female in color except the abdomen is more or less dark brown above, the antennæ are paler and the brown line connecting the ocelli is lacking. Stigmal club surrounded by a dark, nearly circular clouded area.

There are three males marked with black like the females with the short ovipositor. The abdomen is nearly black above except at tip.

Described from 15 females and 6 males from Allentown, Mo., October, 1893, and 1 male from Kirkwood, Mo., 1 July, 1895. All reared from *Physocarpus opulifolius*, probably from the seeds.

**Megastigmus nigrovariegatus** Ashmead.

*Megastigmus nigrovariegatus* Ashmead. Bull. Colorado Biol. Association, I, p. 26. 1890.

*Megastigmus nigrovariegatus* Cockerell. Bull. 15, Ariz. Exp. Sta., p. 69, 1895.

*Megastigmus aculeatus* Crosby. (in part.) Cornell Agr. Exp. Sta., Bull. 265, pp. 377–379. Figs. 82, 83, 1909.

Female.—Length, 3.4 mm.; abdomen, 1.6 mm.; ovipositor, 2.5 mm.

Vertex, antennal grooves and a spot above clypeus dark brown; face and anterior and dorsal eye margin dull brownish yellow; cheeks, posterior eye margin and occiput shining brownish.

Prothorax bright yellow posteriorly and on the sides, brownish in front on the lateral angles and just above the front coxæ. Mesonotum

brownish yellow, dark brown in front. Mesopleuræ brown. Post-scutellum yellow in the middle, brown on the sides; scutellum brown in front of the furrow, yellow behind. Propodeum brown, finely reticulate punctate, with a pair of strongly curved carinæ most distinct posteriorly marking off a nearly circular central area.

Scape and pedicel yellow beneath, rest of antennæ dark brownish. Legs pale yellow; posterior coxæ at base brownish; posterior femora slightly tinged with brownish. Wings hyaline; stigmal club surrounded by a distinct oval cloud.

Abdomen brownish above, sides brownish yellow, indistinctly marked with darker brownish. Ovipositor black.

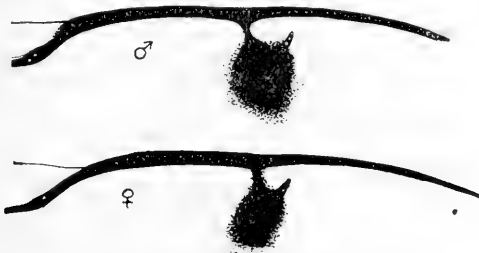

Fig. 3. *Megastigmus nigrovariegatus*.

Described from one ♀, Vancouver Island, a paratype.

In some specimens the yellowish band around the eye is complete. Sometimes the brownish area above the clypeus is lacking and the posterior femora are entirely yellow.

Male.—Length 2.8-3mm.; abdomen .9-1.4mm. (Measurements taken from alcoholic specimens). The males vary greatly in size and color. The lighter males resemble the females closely in color. Sometimes the head is all yellow except the upper half of the occiput, in others it is black except the face and portions of the ring around the eye. In some the thorax is as light as in a female, while in others it is nearly black except an irregular area on the disk and two greenish yellow spots near the posterior margin of the pronotum. In most of the males the propodeum is dark brown to black, but in the lightest specimens it is yellow. In the darkest specimens the abdomen is nearly black except the yellow tip. In the light specimens the legs are yellow, in the dark ones they are more or less brownish on the femora and tibiæ. Stigmal club much larger and darker than in female and surrounded by a clouded area.

In the National Museum collection in addition to the paratype and 4 ♀ ♀ from Vancouver Island are the following specimens belonging apparently to this species. 1 ♀, Algonquin, Ill., June 27, 1894. Labeled "Type, *Megastigmus illinoënsis* Ash." 3 ♀, Jamaica Plain, Mass. (J. G. Jack). 1 ♀, Natrona, Pa.

1 ♀, Pullman, Wash., 30, June, 1898 (C. V. Piper) "Reared from *Clisiocampa plumalis*." This specimen is imperfect, having lost the abdomen and may not belong here.

Cockerell captured specimens of this species on rose hips in Arizona and suggested that they may possibly breed in them. I have reared this species abundantly from rose seeds from Ithaca, White Church, and Wellsville, N. Y., Waukegan, Ill., Durham, N. H. (Charles Spooner), Boston, Mass. (Ralph Curtis), Provo, Utah (R. V. Chamberlin), and Newark, Del. (C. O. Houghton). Professor J. G. Sanders sent me specimens reared from the seeds of *Rosa rugosa*, at Madison, Wis. Mr. Nathan Banks has sent me 9 specimens reared from rose hips at Falls Church, Va.

Some of these localities are listed under *M. aculeatus* in Cornell Exp. Sta. Bull. 265 because at that time I had not separated these two species. It is probable that *nigrovariegatus* is the native American species infesting rose seeds and that *aculeatus* has been introduced recently, since I have reared it from material collected at Ithaca only.

#### **Megastigmus pinus** Parfitt.

*Megastigmus pinus* Parfitt. Zoologist, pp. 5543, 5545, 5629. 1857.

*Megastigmus pinus* Rohwer. U. S. Bur. Ent., Tech. Bull. 20, pt. VI, p. 160. 1913.

Female.—Length, 4 to 5 mm.; abdomen, 2.3 mm.; ovipositor, 5 to 5.5 mm.

Vertex and occiput black; face, cheeks and a ring around eye yellow, the latter broadly interrupted by the black of the vertex which attains the eye-margin below the level of the front ocellus; antennal furrows black; below the insertion of the antennæ there is a circular area cut off from the rest of the face by two or four brownish spots, very variable in shape and distinctness; hairs on the face light colored, above the base of antennæ, brown. Vertex and front transversely rugulose; cheeks and lower part of occiput smooth; face with lines radiating from the clypeus.

Prothorax black, with the sides and a large posterior dorsal band greenish yellow; this band is usually biconvex in front. Mesothorax black with an oblong reddish orange area covering the posterior half of the middle lobe, the inner angles of the scapulæ and axillæ and all of the scutellum. In some small specimens this orange area is obscured by blackish in the center. Sculpture of mesonotum distinctly transversely rugulose. Scutellum with the transverse stria distinct. Pleuræ black, scapulæ have a large greenish yellow spot in front of tegulæ. Postscutellum black with a transverse median band of light yellow. Propodeum black, irregularly rugose with a delicate median carina.

Scape yellow below, black above; pedicel black above, paler at tip beneath; rest of antennæ brownish. Front coxæ yellow; middle coxæ yellow in front, black behind; hind coxæ black; legs yellowish, the middle and hind pairs successively darker; a brownish stripe on outside of posterior femora. Spines on posterior tibiæ white and small. Wings hyaline, no cloud surrounding stigmal club.

Abdomen strongly compressed. Segments 2, 3 and 4 brownish black above, polished; rest of abdomen yellow to yellowish brown with a row of large brownish black spots on each side; segment 8 and ventral keel brownish black. Ovipositor brown and strongly curved.

Male.—Length, 3 mm.; abdomen, 1.3 to 1.9 mm.

Head marked as in female but there are no brownish spots below the insertion of the antennæ. Thorax black; median orange-red area lacking; prothorax has the sides yellow and there are two widely separated transverse dull yellowish spots near the posterior margin; usually the outer angle of the scapulæ has a yellow spot in front of the tegulæ. Stigmal club surrounded by a very narrow clouded area.

Abdomen shorter than in the female, somewhat compressed, seen from above distinctly clavate, yellow beneath, black above, tip orange yellow.

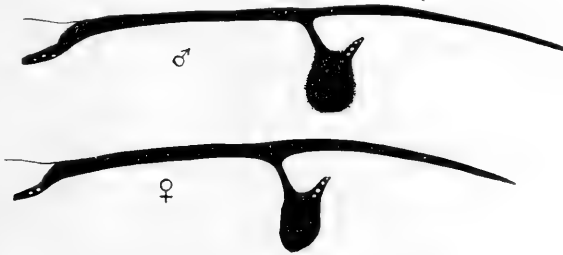

Fig. 4. *Megastigmus pinus*.

This species was first described by Parfitt from females only reared from seeds of *Picea bracteata*, *Pinus Abies nobilis*, and a new species of *Thuja* from California. In a later article he described the male reared from another lot of seeds. Mr. Charles O. Waterhouse of the British Museum has very kindly sent me four specimens which he had carefully compared with Parfitt's types. He also sent me three male specimens of *M. spermotrophus* which he had found to agree with the types from which Parfitt drew his description of the male of *M. pinus*. Ashmead seems to have been misled by this description of the male of *M. spermotrophus* as the male of *pinus* when he states (*Chalcis-flies*, p. 244) that the two species are identical.

2 ♀, 2 ♂ C. O. Waterhouse (Col. British Museum); 16 ♀, 10 ♂ reared from cones of *Abies nobilis*, Astoria, Oregon. No. 5818, Nat. Mus. The following specimens were reared by

Mr. Herman Borries, of Copenhagen, from seeds from the Western United States: 3 ♀ reared from *Abies magnifica* and *concolor*; 1 ♀, 1 ♂ from *A. grandis*; 2 ♀, 1 ♂ from *A. amabilis*. I have also examined the following specimens from the U. S. Bureau of Entomology through the kindness of Mr. S. A. Rohwer. 15 ♀ and 12 ♂ reared from the seeds of *Abies magnifica* from Tahoe, Calif. National Forest. 2 ♀ and 6 ♂ reared from the seeds of *Abies concolor* from Sierra, Calif. National Forest, 30 May, 1912, collected by J. M. Miller. The specimens from *A. concolor* are somewhat smaller and generally darker in coloration.

The female reared from *A. grandis* by Borries may represent a distinct species but it is impossible to decide from such scanty material. The yellow area on the prothorax is very large, covering nearly the whole dorsal aspect and on the vertex there is on each side a branch of the circumorbital yellow band which curves around behind the lateral ocellus. The male is not in good condition for study.

**Megastigmus tsugæ** n. sp.

Female.—Length, 2.5 mm.; abdomen, 1.1 mm.; ovipositor, 1.8 mm.

Face and cheeks yellow; occiput, vertex and front black; the upper posterior orbits and a spot at the upper angle of the eye yellowish brown. Antennal grooves black. Prothorax black with two angular, widely separated dorsal spots and the anterior half of the lateral part yellow. Rest of the thorax shining black. Mesonotum and scutellum finely shingled.



Fig. 5. *Megastigmus tsugæ*.

Scape and pedicel yellow beneath. Anterior coxæ yellow, middle coxæ brownish yellow, posterior coxæ black; rest of legs yellowish; base of femora and band at middle of tibiæ on middle and posterior legs brownish. Wings hyaline; stigmal club not surrounded by a clouded area. Abdomen black with five more or less distinct yellow bands at the sides; tip yellowish. Ovipositor black.

Described from 2 females reared by Mr. Herman Borries from seeds of *Tsuga Mertensiana hookeriana* from the Western United States. Type in the U. S. National Museum.

***Megastigmus lasiocarpæ* n. sp.**

Female.—Length, 3.7 mm.; abdomen, 1.5 mm.; ovipositor, 3. mm.

Thorax and abdomen black. Face and partial ring around eye yellow, a pair of large triangular brownish spots on the face; rest of head black. An elongate light yellow spot on the side of the prothorax. Transverse lateral spots on the sides of abdomen yellow. Head finely rugulose with the lines radiating from the mouth and ocelli. Thorax transversely finely rugulose and shingled.

Antennæ brownish black, scape and pedicel yellow beneath. Legs brownish, posterior femora black except at tip. Anterior coxæ yellow, black at base, the other coxæ black. Wings hyaline; stigmal club not surrounded by a clouded area.

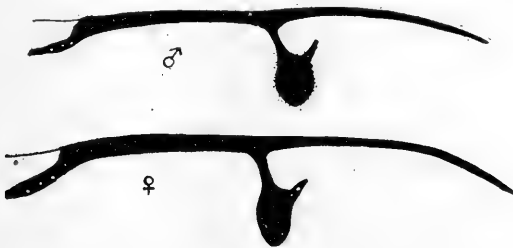

Fig. 6. *Megastigmus lasiocarpæ*.

Male.—Length, 2.4 mm.; abdomen, 1 mm.

Vertex, upper part of occiput and front half way to base of antennæ, black; face, cheeks, lower occiput and a narrow spot along upper eye-margin, yellow. Whole dorsal aspect of thorax black; the yellow spot on side of prothorax is larger than in female. Abdomen black.

Antennæ brownish, scape yellow in front, pedicel nearly black above. Front coxæ yellow, middle coxæ yellow, blackish at base, hind coxæ black. Legs yellowish, suffused with brownish distally; posterior femora brownish on outer surface. Stigmal club darker than in female and more nearly circular.

Described from 2 ♀ 1 ♂ reared from seeds of *Abies lasiocarpæ* kindly sent me by O. S. Mackelfresh, from Rye, Colorado, 5 June, 1909.

***Megastigmus spermotrophus* Wachtl.**

*Megastigmus spermotrophus* Wachtl. Wien. Ent. Zeit., XII, p. 24. 1893.

*Megastigmus pinus* Parfitt. Zoologist, XV, p. 5731. 1857 (Male only).

*Megastigmus spermotrophus* MacDougall. Trans. Roy. Arbor. Soc., XIX, pp. 52-65. 1906. Figure and account of habits.

*Megastigmus spermotrophus* Crosby. Cornell Exp. Sta. Bull. 265. pp. 379-380. Figs. 85-89. 1909.

*Megastigmus spermotrophus* Rohwer. U. S. Bur. Ent., Tech. Bull. 20, pt. VI, p. 160. 1913.

Female.—Length, 3–3.5 mm.; abdomen, 1.8 mm.; ovipositor, 1.6 mm.

General color a yellowish brown. Face and cheeks lighter than the vertex. Face with fine lines radiating from the clypeus; vertex and thorax finely transversely rugulose. Head and thorax clothed with stiff black hairs arising from black tubercles. Median area on postscutellum, greenish yellow. Propodeum with a distinct median carina.

Antennæ brownish, scape yellow beneath, pedicel nearly black above. Legs including the coxæ paler than the thorax. The posterior coxæ clothed with stiff light-colored hairs, arising from black tubercles. Wings hyaline; stigmal club not surrounded by a cloud; stigmal vein as long as the width of club.

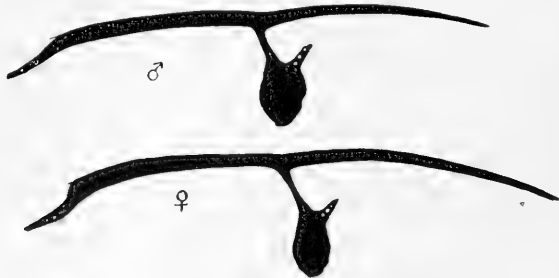

Fig. 7. *Megastigmus spermotrophus*.

Male.—Length, 2.9–3.3 mm.; abdomen, 1.2–1.7 mm. (Measurements taken from alcoholic specimens.)

Head, thorax and legs a clearer yellow than in the female. On the front of the pronotum a dark brown spot is sometimes present which is sometimes divided into two. Sometimes the front of the mesothorax is black and shows through the posterior edge of the prothorax. Median and anterior portion of the propodeum black; sides and posterior margin yellow. Stigmal club darker than in female, not surrounded by a clouded area.

Abdomen brownish yellow, black at base above.

Described from numerous specimens of both sexes reared from seeds of the Douglas Fir sent me by Mr. John Crozier, of Aberdeenshire, Scotland.

The egg as obtained by dissection of the female is white, smooth and spindle-shaped with a very long pedicel at the anterior end and the vestige of one at the opposite end. Length of body of egg, .36 mm.; tail like process, .9 to 1.2 mm.

The full grown larva is yellowish white with brownish mouthparts; its length varies from 2.5 to 3.5 millimeters. The surface is smooth without apparent sculpture and the hairs are very sparse and microscopic in size. The inner margin of the mandibles is provided with three sharp teeth.



The pupa is yellowish white and in the female has the ovipositor curved over the back and reaching to about the middle of the thorax. Length of female pupa, 3 mm.; of male, 2.5 mm.

While originally a native of the Western United States it has been introduced into Europe and has there become a serious pest. The male of this species was described by Parfitt in 1857 as the male of *M. pinus*. Mr. Charles O. Waterhouse of the British Museum has kindly sent me three males of this species which he compared with Parfitt's types. Saftro (Jour. Ec. Ent., VI, p. 283. 1913.) records rearing this species from seed of Douglas Fir in Washington.

The species listed under B in Riley's article (Proc. Ent. Soc. of Wash, II, p. 360) also belong to this species. They were reared from seeds of *Pseudotsuga douglassi*, [*taxifolia*], *Abies magnifica*, *A. grandis*, *A. amabilis* and *A. concolor*.

Through the kindness of Mr. S. A. Rohwer I have been able to examine specimens from the U. S. Bureau of Entomology as follows: 4 ♀ 4 ♂ reared from seed of *Pseudotsuga taxifolia* from Yreka, Calif., April and May. 3 ♀ 2 ♂ reared from seed of *Abies magnifica* from Tahoe, Calif. National Forest, June, 1912; 1 ♀ 1 ♂ from seeds of *Abies concolor*, from Sierra, Calif. National Forest (J. M. Miller, Collector).

#### *Megastigmus aculeatus* Swederus.

- Pteromalus aculeatus* Swederus. Vetensk. Akad. nya Handl., XVI, p. 221. 1795.  
*Torymus collaris* Boheman. Vetensk. Akad. nya Handl., LIV, p. 332. 1833.  
*Megastigmus transversus* Walker. Ent. Mag. I, p. 117. 1833.  
*Torymus punctum* Förster. Beitr. Monogr. Pteromal, p. 29. 1841.  
*Megastigmus vexillum* Ratzeburg. Ichn. d. Forstinsect. II, p. 182. 1848.  
*Megastigmus transversus* Reinhard. Berl. Ent. Zeitschr., I, p. 76. 1857.  
*Megastigmus flavus* Förster. Verh. Nat. Ver. preuss. Rheinl. XVI, p. 109. 1859.  
*Megastigmus collaris* Mayr. Verh. zool.-bot. Ges. Wien. XXIV, p. 137. 1874.  
*Megastigmus aculeatus* Thomson. Hymen. Scand. IV, p. 1. 1875.  
*Megastigmus cynorrhodi* Perris. Ann. Soc. Ent. Fr., 1876, p. 222.  
*Megastigmus aculeatus* Cameron. Trans. Ent. Soc. Lond., 1879, p. 118.  
*Megastigmus collaris* Wachtl. Wien. Ent. Zeit., III, pp. 38, 39. 1884.  
*Megastigmus aculeatus* Crosby. (In part). Cornell Exp. Sta., Bull. 265, pp. 377-379. 1909.

Female.—Length, 3 mm.; abdomen, 1.5 mm.; ovipositor, 4 mm.

General color brownish yellow. Face and cheeks yellow; vertex brownish yellow; occiput with a narrow band of black above the opening. Pronotum pale yellow behind, mesonotum black in front where it shows through the thin posterior edge of the pronotum, the anterior half reddish yellow; axillæ black except the inner angle; anterior half of the propodeum black or dark brown. Median carina of propodeum not pronounced. Median part of the postscutellum greenish yellow.

Antennæ very dark brown, nearly black, scape beneath yellow. Legs yellow, wings hyaline. Stigmal club oval, not surrounded by a cloud, the stigmal vein shorter than the width of club.

Abdomen brownish yellow on the sides, dark brown above banded with yellow. Ovipositor longer than body, black and curved.



Fig. 8. *Megastigmus aculeatus*.

Described from numerous specimens reared from rose seeds at Ithaca, N. Y. In Bull. 265, Cornell Exp. Sta. I have confused this species with *M. nigrovariegatus*. All the other localities there given refer to that species. Figures 82 and 83 are also of *nigrovariegatus*. In the collection of the U. S. National Museum there is a series of specimens reared from rose seeds imported from Peking, China. I have also reared several specimens from rose hips from Heilbronn, Germany, procured for me by Mr. Carl Ilg from his friend, Mr. Gustav Wieland.

#### ***Megastigmus flavipes* Ashmead.**

*Megastigmus flavipes* Ashmead. Trans. Am. Ent. Soc. XIII, p. 128. 1886.

“Male.—Length, .12 inch. Head and thorax bright golden green, face finely reticulately strigose; thorax irregularly, transversely, coarsely strigose; antennæ clavate, scape and flagellum beneath yellow, flagellum above brown-black; the collar is rather short; the scutellum at tip is divided by a transverse suture and with a raised rim at border posteriorly; abdomen ovate, black; legs waxy yellow; wings hyaline, veins pale, excepting the stigmal vein, which is brown, and ends in a circular stigma.

“Described from one specimen taken in August.”

In the United States National Museum collection there is the pin on which the type was originally tag-mounted. Only the hind legs and one front wing remain. The stigmal club is large, very dark colored and appears to be surrounded by a narrow clearly defined cloud.

In 1888 (Bull. 3, Kansas Agricultural Experiment Station, p. III) Ashmead described another species under the same name, *Megastigmus flavipes*. Through the kindness of Professors T. J. Headlee and G. A.

Dean, I have been able to examine the type of this species. It is a male *Torymus*. As the original description is rather brief I will publish a more complete description elsewhere.

***Megastigmus albifrons* Walker.**

*Megastigmus albifrons* Walker. Trans. Ent. Soc. London, 1869. p. 314.

Female.—Length, 5 mm.; abdomen, 2 mm.; ovipositor, 4 mm. (abdomen contracted in drying).

Head yellowish white, with many black punctures from which arise black hairs; on the middle of the face the hairs are yellowish; an area including the ocelli and extending almost to the eye margin, black.

Prothorax dull yellowish, the dorsum marked with a wedge-shaped black spot from the front corner of which a black line curves around along the lateral margin and almost reaches the posterior edge of the segment. Central lobe of the mesonotum black except along the lateral edge; lateral lobes brownish, blackish in the center. Scutellum black except along side and at apex where it is yellowish brown. Axillæ black in the center, surrounded by yellowish brown. Post scutellum yellowish white in the center, black on the sides. Propodeum black, yellowish white at the sides. Pleuræ yellowish white.

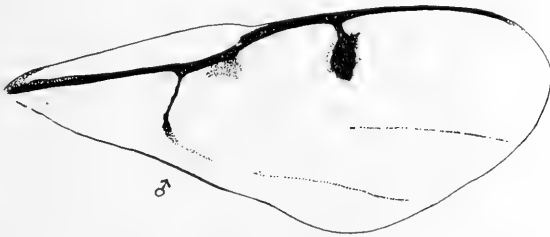

Fig. 9. *Megastigmus albifrons*.

Antennæ brownish, scape yellowish at base and below. Legs yellowish brown; tarsi blackish at tip. Front wings hyaline with a distinct brownish spot adjoining the hind margin of the submarginal vein beyond the junction with the basal vein. Basal vein unusually distinct. Stigmal club surrounded by an indistinct clouded area scarcely discernible when viewed with a hand lens.

Abdomen shining black above, spotted with dull-yellowish on the sides and below. Ovipositor black, the extreme tip yellowish.

Male.—Length, 6 mm.; abdomen, 2.5 mm.

Head similar to female. Thorax dull yellowish marked with a black median line, enlarged in front on the prothorax, narrower on the median lobe of the mesothorax and again enlarged on the scutellum. The lateral black marking on the prothorax of the female is here replaced with brownish.

Mesonotum distinctly brownish. Axillæ black along the anterior margin. Legs more distinctly brownish than in the female. In the fore wing the brownish spot adjoining the submedian vein is more distinct than in the female, and the stigmal club is surrounded with a distinct clouded area.

Abdomen shining black above, brownish yellow below.

Described from 1 ♀ and 1 ♂. Placerville, Cal., 8 Feb., 1913. Reared by J. M. Miller from the seeds of *Pinus ponderosa*. Received through the kindness of S. A. Rohwer.

*Megastigmus canadensis* Ashmead (Trans. Am. Ent. Soc., XIV, p. 186. 1887).

The type in the United States National Museum is a male Pteromalid.

Through the kindness of Dr. Henry Skinner, I have been permitted to examine specimens of the two following species in the collection of the American Entomological Society.

*M. cecidomyiæ* Ashmead (*l. c.* XIV, p. 185. 1887).

Two specimens, male and female, both tag-mounted on the same pin, "E. Fla., Ashmead" and labeled with the name in Ashmead's hand-writing. They belong to the genus *Lochites*.

*M. ficigeræ* Ashmead (*l. c.* IV, p. 185. 1887). One male. The head is glued to the card point separately. The antennæ are lacking. It is apparently an Encyrtid. "E. Fla. Ashmead." Name in Ashmead's handwriting.

These specimens were probably the ones from which Ashmead drew up his description of the species.

In 1892 C. V. Riley received a series of specimens of *Megastigmus* reared from the seeds of various conifers by Mr. Herman Borries, of Copenhagen, Denmark. He published (Proc. Ent. Soc. Wash. II, pp. 359-363) an article on the habits of this genus in which he gave a list of the specimens reared by Mr. Borries and data in regard to the host plants. I have examined these specimens in the National Museum Collection and for convenience quote the list and indicate the species to which each lot belongs.

"A. Very handsome species marked with black, red, and yellow. II and V from *Abies magnifica* and *concolor*, somewhat smaller and paler; III, from *A. grandis*, distinctly smaller, much paler; IV, from *A. amabilis*, larger and darker. ♂ and ♀ of all varieties. [*M. pinus* Parfitt.]

"B. Entirely yellow species, also variable; perhaps two species mixed. I, from *Pseudotsuga douglassi* [*taxifolia*] ♂ and ♀; II, from *Abies magnifica*; III, from *A. grandis*; IV, from *A. amabilis*; V, from *A. concolor*. [*M. spermotrophus* Wachtl.]

"C. Very small, dark species, very similar to small specimens of the European *M. strobilobius*. From *Tsuga* [*mertensiana*] *hookeriana*. 2 ♀ [*M. tsugæ* n. sp.]

"D. Entirely black species from Japan. From *Abies mariesi* 2 ♀. [*M. borriesi* n. sp.]

"E. *M. strobilobius* Ratzeb. from Denmark. 5 ♀."



Fig. 10. *Megastigmus borriesi*.

\**Megastigmus borriesi* n. sp.

Female—Length, about 3.3 mm.

Head, thorax and abdomen dark brown, nearly black; yellowish around mouth. Antennæ of the type still in pupal sheaths. Scape brownish lighter beneath. Legs brownish yellow, the posterior femora darker. Coxæ dark brown like the thorax. Wings hyaline, the stigmal club without a surrounding cloud. Ovipositor as long as abdomen.

Described from two females in rather poor condition. Reared by Mr. Herman Borries from seeds of *Abies mariesi* from Japan.

51111—Type-Paratype nos. 27519

TABLE OF HOSTS.

- M. aculeatus* Swederus—Rose seeds.  
*M. albifrons* Walker—Seeds of *Pinus ponderosa*.  
*M. brevicaudis* Ratzeburg—Seeds of Sorbus.  
*M. borriesi* Crosby—Seeds of *Abies mariesi* from Japan.  
*M. flavipes* Ashmead—Unknown.  
*M. lasiocarpæ* Crosby—Seeds of *Abies lasiocarpa*.  
*M. nigrovariegatus* Ashmead—Rose seeds.  
*M. physiocarpi* Crosby—Seed capsules of *Physocarpus opulifolius*.  
*M. pinus* Parfitt—Seeds of "*Picea bracteata*," *Abies nobilis*, *Abies magnifica*, *Abies concolor*, *Abies grandis*, *Abies amabilis*.  
*M. spermotrophus* Wachtl—Seeds of *Pseudotsuga taxifolia*, *Abies magnifica*, *Abies grandis*, *Abies amabilis*, *Abies concolor*.  
*M. tsugæ* Crosby—Seeds of *Tsuga mertensiana hookeriana*.

## ACKNOWLEDGMENTS.

My indebtedness to the many persons who have aided me in the preparation of this paper by the loan of specimens and other material and in other ways is duly acknowledged in the preceding pages. My thanks are especially due to the authorities of the United States National Museum and of the Bureau of Entomology at Washington for the loan of many specimens and to Mr. C. O. Waterhouse of the British Museum for an examination of Parfitt's types.

The drawings were all made by Miss Anna C. Stryke, of Ithaca, N. Y.

## THE NEUROPTEROUS GENUS PALPARES.

By NATHAN BANKS.

To the genus *Palpares* belongs the most magnificent of the Neuropterous insects. Their large size and contrasting markings has attracted even the collector of butterflies so that now a considerable amount of material exists in the various museums, a much more representative collection than any other group of exotic Neuroptera.

Having recently seen many of the collections and having a number of species in my own, I have endeavored to prepare a table with such notes as may be useful in identifying the various species.

Africa is the home of the genus, two species occur in Southern Europe, several in India and Persia, and one has been taken in the Madeira Islands. Elsewhere there are none, nor even a closely allied genus.

Several attempts have been made to divide the genus. Hagen made *Stenares* for those species in which the costal cells were crossed. This character is often variable in development, in many Myrmeleonidae, but in *Palpares* it appears to be more constant; the species of *Stenares* always have two rows of cells for most of the costal length, while in the true *Palpares* it is rare to find even one cell crossed. *Panexis* was created by Hagen for certain small, broad-winged species, the type of which has a thickened subcosta. Until better characters are given, it is best to keep *Panexis* as only a subgenus.

McLachlan proposed to divide both *Palpares* and *Stenares* according to whether the outer margin of the wings were strongly sinuated or not. Thus *Symmalthetes* is for species of *Palpares* with sinuated margin and *Crambomorphus* is for those *Stenares* with a sinuated margin. However as we know more species of *Palpares* it becomes increasingly difficult to tell whether the margin is strongly sinuated or not; thus *P. amitinus*, *P. insularis*, *P. inclemens* and *P. latipennis* all have the margin plainly sinuated, and other species show this character in a slight degree. Lately Navas has proposed various new genera. *Nosa* for *P. tigris* which has apparently two radial sectors, although in reality it has no more longitudinal veins than other *Myrmeleonidae*. *P. tigris* is so closely related by other characters to species with but one radial sector that I cannot

consider it generically different from *Palpares*. *Palparellus* was made by Navas for *P. spectrum*, but *P. ovampoanus* connects this group with the section of *P. flavofasciatus*.

*Golafrus* was made for *P. oneili* on account of the emargination at base of the fore wing. I suspect this character exists only in the male sex, besides *P. oneili* is otherwise related to *P. radiatus*.

If these names are to be used for subgenera, others should be created for other sections or groups. In the appended notes I have given certain facts regarding the anal venation which, although not sufficiently different to divide the genus, are fairly constant for each species. The color of the legs is valuable, and I tabulate the black and pale legged species below.

The color of the vertex and the presence of spots on thorax and on abdomen are also very useful. The point of origin of the radial sector in the fore wings is also useful; in *P. libelluloides* it is as far basad as the cubital fork, in many other species it is plainly beyond this point.

The palpi are variable in length according to the species; in *P. libelluloides* the last joint of the maxillary palpi is much longer than the space between the eyes, in *P. speciosus*, *P. moestus* etc., it is shorter. The male appendages also vary in length, but little in structure; in *P. speciosus* and allies they are very short, in *P. tigris* very long and with a basal tooth.

The markings of the wings, although variable in development, are extremely useful, especially the shape of the apical marks. It is doubtful if the character of median band across hind wing is of specific value. The size of species does not vary much, but the width of the hind wings does vary to some extent in the same species. The width of the face between the eyes is very narrow in *Palparellus* and the *flavofasciatus* group, in others wider. In the table I have placed a number of names as synonyms, based (in most cases) on my examination of the types, but I am quite certain that a still greater number should also be placed as synonyms, or at most varieties. All the species allied to *P. speciosus* are probably but forms of that species, for the marks are all on the same plan and the male genitalia the same. Likewise several species will later fall under *P. tristis* as collections are more extensive.

*P. cognatus* Rbr I have not seen, nor been able to place it; its habitat is unknown.



Arranged according to the color of legs they are as follows:

Legs all black, or pale on part of tarsi.

*speciosus*, *caffer*, *digitatus stuhlmanni*, *flavofasciatus*, *festivus*, *formosus*, *amitinus*, *insularis*, *spectrum* (and allies) *damarensis*, *tigroides*, *cataractæ*, *immensus*, *contrarius*, *pardaloides*.

Legs with pale on femora or tibiæ.

*libelluloides*, *hipahus*, *pardus*, *inclemens*, *latipennis*, *nyicanus*, *ægrotus*, *tristis*, *tigris*, *obsoletus*, *mæstus*, *interioris*, *angustus*, *oneili*, *sparsus*, *radiatus*, *tessellatus*, *furfuraceus*, *zebratus*.

The species may be arranged in the following groups:

*væltzkowi* group.

Includes also *obscuripennis*.

*mæstus* group.

Includes *cataractæ*, *martini* and *contrarius*.

*flavofasciatus* group.

Includes also *compositus*, *formosus*, *damarensis*, *bifasciatus*, *festivus*, and *elegantulus*.

*spectrum* group.

Includes also *rothschildi*, *astutus*, and *ovampoanus*.

*luteus* group (*Pamexis*).

Includes also *translatus* and *contaminatus*.

*speciosus* group.

Includes also *digitatus*, *caffer*, *varius*, *stuhlmanni*, and *dubiosus*.

*libelluloides* group.

Includes also *papilionoides*, *hispanus*, *percheroni* and *tessellatus*.

*solidus* group.

Includes also *walkeri*, and *angustus*.

*tigris* group (*Nosa*).

Includes also *ægrotus*, *ornatus*.

*pardus* group.

Includes also *tigroides*, *zebratus*.

*tristis* group.

Includes also *interioris*, *obsoletus klugi*, *extensus*, *lentus*, *similis*, *pardaloides*, *nigrita*.

*sparsus* group.

Includes also *sobrinus*, *furfuraceus*, *abyssinicus*, *nyicanus*.

*cephalotes* group.

Includes also *inclemens*, *incommodus*, *latipennis*, *radiatus*, *immensus*, *o'neili*, *astarte*, *patiens (infirmiss)*, and *karrooanus*.

*insularis* group.

Includes also *amitinus*.

*gigas* group.

No others known.

The African species are tabulated below, after which are the Indian species.

#### TABLE OF AFRICAN SPECIES.

- Hind margin of fore wings with a long emargination at base; wings narrow, streaked with dark..... *o'neili* Per.  
Hind margin not emarginate near base.....2.
- Anterior apical margin of hind wings straight or slightly concave, tip acute; large heavily marked species the outer margin of wings sinuate...*gigas* Dal.  
Anterior apical margin of hind wings convex.....3.
- Hind wings mostly black on the basal part before cubital fork as elsewhere; with only isolated pale spots.....4.  
Hind wings largely pale, and pale on basal part before the cubital fork...5.

4. Wings slender, acute at tips; hind pair with a pale apical streak.....  
*karrooanus* Per.  
 Wings broader, not acute; hind pair without apical streak; several isolated pale spots.....*valtzkowi* Weele
5. Vertex dark or blackish, legs wholly black.....6.  
 Vertex pale, with a median dark stripe, or at least outlined by pale spots.....26.
6. A large spot at or near the cubital fork in the hind wings.....16.  
 No spot near cubital fork in hind wings, the base being all pale.....7.
7. In hind wings the dark extends along the costa to base.....8.  
 In hind wings the dark does not extend to base, at most some isolated dark marks.....10.
8. Fore wings with large pale space in the middle, wings rather slender.....  
*ovampoanus* Per.  
 Fore wings without a large pale space in middle.....9.
9. Both wings with pale post-stigmal bands.....*spectrum* Rbr.  
 These bands broken into spots.....*rothschildi* Weele
10. Fore-wings dark, with black bands; hind wings with nearly two-thirds black with small white spots; expanse over 100 millimeters.....  
*obscuripennis* Sch.
- Fore-wings yellowish or hyaline in pale areas.....11.
11. The subcosta of fore wings thickened near the stigma, wings yellow with dark bands, hind wings very broad.....*luteus* Thunb.  
 The subcosta of fore wings not thickened.....12.
12. Median band of hind wings does not reach up to the radius, but from middle of wing behind in form of three spots.....*contaminatus* Hag.  
 Median band of hind wings reaches across the wing from radius to hind margin.....13.
13. Apex of fore-wings dark with a distinct pale band before it.....14.  
 Apex without such marks.....15.
14. Dark bands of hind wings not connected.....*flavofasciatus* McLach.  
 Dark bands of hind wings connected.....*compositus* Navas.
15. Fore and hind wings with apical marks in the form of longitudinal streaks.....  
*elegantulus* Per.  
 These marks not in the form of streaks, but band or spots.....*festivus* Gerst.
16. Small very broad-winged species; greatest breadth of the hind wings much beyond the middle; basal band of the fore wings reaches to the hind margin.....  
*translatus* Walk.  
 Larger; wings more slender; greatest breadth of hind wings at middle of length or before.....17.
17. Hind wings with the stigmal band broad and in front in two parts; wings not yellowish; basal band of hind wings nearly across, or in two nearly connected spots.....*cataractæ* Per.  
 Hind wings with the stigmal band entire on the front margin.....18.
18. Abdomen pale yellowish red; wings yellowish brown; small species; bands of hind wings narrow, apical mark in form of two streaks.....*bifasciatus* Oliv.  
 Abdomen pale on base, darker toward tip.....19.
19. Pronotum with yellow each side; fore wings often more or less yellowish, and the median and stigmal bands often only spots with dark borders; thorax very hairy, not showing the pale spots, male appendages very short...21.  
 Pronotum with two yellowish spots on front margin (maybe connected); pale median spots on thorax visible.....20.
20. Few spots between stigmal and median bands in fore wings; apical mark in form of streaks.....*damarensis* McL.  
 Many spots between bands; apical mark not in form of streaks.....*formosus* Bks.
21. Bands of hind wings connected together; apical mark of hind wings encloses but one pale spot.....*stuhlmanni* Kolb.  
 Bands of hind wings separate.....22.
22. In fore wings the small basal spots are arranged so as to leave two clear longitudinal streaks; stigmal and median bands of hind wings reach across with two or three fingers each; sides of pronotum more narrowly yellow.....  
*digitatus* Gerst.  
 Basal spots of fore wings not arranged to leave clear spaces; sides of pronotum broadly yellow.....23.

23. Hind wings tessellate with spots along the hind border.....24.  
Hind wings not tessellate with spots along the hind border. . . . . *dubiosus* Per.
24. Bands of hind wings reach across; wings rather more narrow. . . . . *speciosus* L.  
Bands of hind wings do not reach across. . . . . 25.
25. Spots greatly reduced in size. . . . . *varius* Nav.  
Spots of moderate size. . . . . *caffer* Burm.
26. A large spot on the forking of the cubitus in the hind wing . . . . . 51.  
Only a small dot on this forking, but sometimes there are marks near by,  
above or around the forking. . . . . 27.
27. Hind margin of both wings narrowly, evenly fumose all along; stigmal spot  
of fore wings hardly reaches the radius; bands of hind wings not reaching  
across the wing. . . . . 28.  
Hind margin of the wings with at most separated dark spots; not evenly  
fumose all along, always some pale spaces. . . . . 30.
28. Fore wings with apparently two radial sectors arising close together; the  
lower of the apical spots is triangular; no band below antennæ. . . . . *tigris* Dalm.  
Fore wings with but one radial sector; a black band below antennæ. . . . . 29.
29. Stigmal band of hind wings concave within; lower apical mark of fore wings  
hardly in form of two streaks. . . . . *ornatus* Nav.  
Stigmal band of hind wings not concave within, often broken; lower apical  
mark of fore wings in form of two parallel, slightly curved streaks. . . . .  
*ægrotus* Gerst.
30. Fore wings with many small dark spots, and no large spots or bands. . . . . 31.  
Fore wings with large spots (perhaps netted) or bands. . . . . 35.
31. Hind wings with all small spots. . . . . 32.  
Hind wings with some moderately large spots. . . . . 33.
32. Longitudinal space behind the first branch of radial sector in fore wings pale,  
unmarked. . . . . *sparsus* McLach.  
This space with spots as elsewhere. . . . . *sobrinus* Per.
33. Vertex greatly swollen; thorax with fulvous hair; spots in hind wings mostly  
rounded. . . . . *furfuraceus* Rbr.  
Vertex not so swollen; some spots in hind wings in the form of streaks. . . . . 34.
34. Longitudinal space behind the first branch of radial sector in fore wings  
mostly unspotted. . . . . *abyssinicus* K.  
This space with spots as elsewhere; hind wings with median spots, a spot or  
streak beyond and apical streaks. . . . . *nyicanus* Kolbe.
35. Apical marks of hind wings in the form of longitudinal spots or streaks. . . . . 36.  
Apical marks not so; transverse. . . . . 42.
36. A submarginal line in fore wings. . . . . 39.  
No such line; bands of hind wings not across. . . . . 37.
37. Bands of fore wings usually small and faint; hind margin of hind wings with  
long curved streaks reaching towards the bands; femora not spotted. . . . .  
*obsoletus* Gerst.  
Bands of fore wings distinct; hind margin of hind wings not so plainly  
streaked, mostly short spots; femora spotted. . . . . 38.
38. Larger, spots not broken up much; face mostly black; abdomen not striped.  
*tristis* Hag.  
Smaller, spots more broken up; the male appendages shorter; narrow band  
below antennæ; abdomen striped. . . . . *interioris* Kolbe.
39. Stigmal mark in the hind wings divided, not reaching across; fore wings with  
an apical cloud. . . . . *klugi* Kolbe.  
Stigmal mark in hind wing entire; fore wings with apical streaks. . . . . 40.
40. Stigmal mark of fore wings in form of a streak; stigmal band of hind wings  
not across. . . . . *immensus* McL.  
Stigmal spot of fore wing band-like. . . . . 41.
41. Stigmal and median bands of hind wings not across. . . . . *similis* Stitz.  
These bands reach across. . . . . *reticulatus* Stitz.
42. Median band of hind wings with a projection toward the cubital fork, or else  
a separated spot near by; stigmal band with upper inner projection and  
also one behind. . . . . 43.  
No such projection to median band, nor a separated spot near by. . . . . 44.

43. Median band of hind wings has a projection toward the cubital fork; large species ..... *latipennis* Rbr.  
 Median band not with a projection, but a large spot near the cubital fork. . . . . *inclemens* Walk.
44. Fore wings with four distinct bands; hind wings with straight bands; no dots along hind border of either wing. . . . . *normalis* Nav.  
 Fore wings with but three bands; bands of hind wings not straight. . . . . 45.
45. Median and stigmal bands of hind wings connected. . . . . *amitinus* Kolbe.  
 Median and stigmal bands separated. . . . . 46.
46. Median band of hind wings reaches across; bands not netted. . . . . 47.  
 Median band does not reach across the hind wing. . . . . 49.
47. Stigmal band of two more or less connected bands; apical mark of fore wing entire; a large costal sub-basal spot dark; outer margin of wings plainly sinuate. . . . . *mæstus* H.  
 Stigmal band of but one band, perhaps with projections; no large sub-basal costal spot in fore wings. . . . . 48.
48. Apical mark of fore wings entire; inner projection of stigmal band of hind wings directed backward. . . . . *insularis* McL.  
 Apical mark of fore wings divided; inner projection of stigmal band of the hind wings directed upward. . . . . *lentus* Nav.
49. Bands netted; median band of hind wings with emargination on the inner side. . . . . *nigrita* Nav.  
 Bands not netted; hind wings rather broader in the middle. . . . . 50.
50. Fore wings with many moderate-sized spots; the stigmal band very small; no other bands; from Madagascar. . . . . *pardaloides* Nav.  
 Fore wings with only small dots and bands; median band of hind wings with an emargination on inner side; large spot on middle of hind margin. . . . . *geniculatus* Nav.
51. Abdomen yellow, each segment with a broad black transverse basal band; no longitudinal stripe; wings broad, fore wings much spotted; in hind wings the bands not across, or only by connected spots. . . . . *hispanus* L.  
 Abdomen with the segments not banded, sometimes lineate or spotted. . . . . 52.
52. Apical marks of hind wings in the form of two streaks. . . . . 53.  
 Apical mark of hind wings transverse or in spots. . . . . 57.
53. Stigmal band of hind wings not reaching across. . . . . 54.  
 Stigmal band of hind-wings reaching across. . . . . *cataractæ* Per.
54. All marks in the form of streaks in both wings. . . . . *radiatus* Rbr.  
 Some spots or bands. . . . . 55.
55. Spots netted; basal band of hind wings not reaching toward base; abdomen yellow with dark spots. . . . . *tessellatus* Rbr.  
 Spots not netted; basal spot usually reaching toward base. . . . . 56.
56. Four stigmal spots in hind wings. . . . . *incommodus* Walk.  
 Two stigmal spots in hind wings; a submarginal line in both wings. . . . . *immensus* McL.
57. Two stigmal bands in hind wings (or broken into spots); a submarginal row of spots. . . . . *cephalotes* Klug.  
 But one stigmal band in hind wings. . . . . 58.
58. Median band of hind wings reach across; small spots along hind border; abdomen dark, not spotted. . . . . 60.  
 Median band not across; hind wings with many small spots; abdomen yellow, lineate with dark. . . . . 59.
59. Abdomen with small spots and dots; bands of wings netted. . . . . *percheroni* Guer.  
 Abdomen lineate, or mostly dark; spots in hind wings not netted. . . . . *libelluloides* L.
60. Stigmal and median bands of hind wings connected; apical mark of hind wings entire. . . . . *walkeri* var.  
 These bands separated. . . . . 61.
61. The stigmal band of hind wings is connected or nearly so to the apical which extends along the hind border. . . . . 62.  
 The stigmal not connected to apical, and latter not extending along the hind border; hind wings very broad in the middle. . . . . *walkeri* McL.
62. Hind wings quite narrow; from North Africa. . . . . *angustus* McL.  
 Hind wings quite broad in middle; from Madagascar. . . . . *martini* Weele.

***Palpares gigas* Dalman.**

Figure—Plate XIX, Figure 17, and Drury, Pl. 41.

The fourth anal of f. w. with three or four branches and three cross-veins; the third anal in h. w. has a strong oblique vein up to second anal. Male appendages nearly twice as long as the last two segments together.

***Palpares moestus* Hag.**

Figure—Plate XIX, Figure 15; Hagen, Mozambique paper.

The fourth anal in f. w. with four or five branches and five or more cross-veins; the third anal of h. w. practically runs into the second, and with two or three cross-veins before it. The antennæ are longer than in *P. gigas*; the thorax with long white hair. Anal appendages of male, Fig. 55.

***Palpares obscuripennis* Schmidt.**

In general this resembles a very large *P. spectrum* but the fore wings are plainly tinged with pink; the pale basal part of hind wings is milky and the black has no complete pale bands, but median and stigmal pale bands reaching one-half way across wing, two spots near apex, and two to four near the hind border.

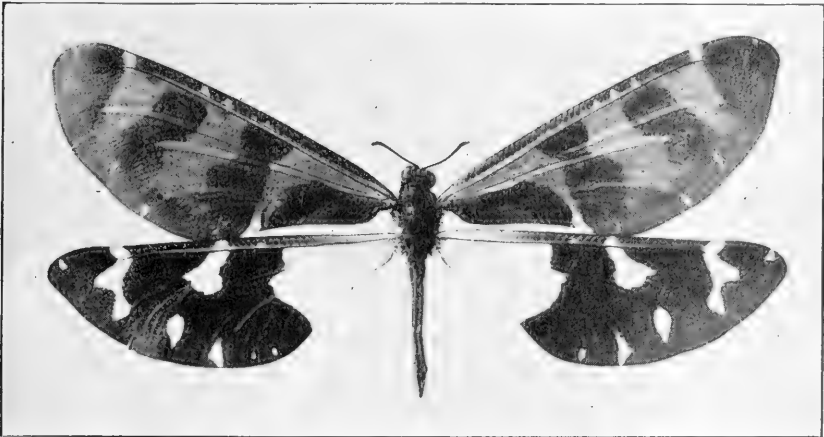

Fig. 1. *Palpares obscuripennis* Schmidt.

I have seen it only in the Stettin (type) and Berlin Museums. It may be the *P. fulvus* McLach; but I was not able to find McLachlan's type in his collection nor elsewhere.

***Palpares martini* Weele.**

Figure—Van der Weele, Madagascar, Figure 3.

This species resembles *P. walkeri*, and in that species the apical mark sometimes almost connects to the stigmal band.

**Palpares cataractæ** Pering.

Figure—Peringuey; and Stitz (as *obscuratus*).

Third anal in h. w. runs into the second, and is connected once or twice to the fourth anal.

This has been redescribed by Stitz as *P. inclemens* W. var. *obscuratus*.

**Palpares vœltzkowi** Kolbe.

Figure—Van der Weele, Madagascar, Figure 4.

A remarkable species, not only on account of the almost wholly black hind wings, but also in the very slender abdomen. Van der Weele figures (p. 255) the male appendages.

**Palpares insularis** McLach.

Figure—Van der Weele, Madagascar, Figure 6, also the male appendages on page 259.

Fourth anal of f. w. with three branches and one or two cross-veins to the third anal. Third anal of h. w. simple, two or three cross-veins to second, none to fourth anal. Black band below antennæ present.

*P. hildebrandti* is the same species.

**Palpares amitinus** Kolbe.

Figure—Van der Weele, Madagascar, Figure 7.

Fourth anal of fore wings long, with four branches and four or five connections to the third anal; third anal of hind wings simple, with two cross-veins to the second, none to the fourth. The legs are black; there is a large interantennal mark reaching much below the antennæ as well as above from eye to eye; the outer apical margin of the fore wings is slightly sinuated, as in several other species.

Van der Weele also figures (p. 262) the male appendages which are short like those of *P. speciosus*.

**Palpares furfuraceus** Rambr.

Figure—Navas (as *equestris*), Broteria, X, p. 56.

Readily known by the greatly swollen vertex and fulvous hair on thorax, which was noted by both describers. It occurs in West Africa.

**Palpares sobrinus** Pering.

Figure—Peringuey, 1911, p. 33, Figure 3.

I can find no differences between this species and *P. nudatus* Navas; but I have not seen the type of either species; but judge from the figures and descriptions.

**Palpares nyicanus** Kolbe.

Figure—Kolbe, original; and Peringuey, 1911, p. 32, Figure 1 (as *amulus*).

The third anal of h. w. runs apparently into the second, and with four or five cross-veins to the fourth anal.

*P. æmulus* Pering is, I think, the same species, and it is also figured by Calvert, Proc., Acad., Nat., Sci., Phil. 1899, plate X, fig. 2.

***Palpares abyssinicus* Kolbe.**

The third anal of h. w. is simple, and no cross vein to fourth.

This species is very close, if not identical, with *P. nyicanus*, the spots are arranged in oblique streaks.

***Palpares sparsus* McLach.**

Figure—Peringuey, 1911, p. 32, Figure 2.

The third anal of h. w. is simple, and no connection to fourth anal, but one to second. The fourth anal in f. w. is once or twice forked, and with two cross-veins. No band below antennæ.

***Palpares radiatus* Rambur.**

Figure—Rambur, original.

The fourth anal in f. w. with three or four branches, and two or three cross-veins; the third anal in h. w. runs into the second anal. The male appendages (Fig. 40) are curved and as long as the last segment, and enlarged a little at tip. There is no band under the antennæ.

There are but few specimens of this in European collections.

***Palpares incommodus* Walk.**

Figure—Plate XVIII, Figure 2, and by Stitz (*rubescens*) and by Navas (as *rieli*).

The third anal of h. w. appears to run into the second, two cross-veins behind to the fourth anal. In fore wings there is no line near the outer margin parallel thereto, but oblique streaks outward.

*P. costatus* Navas is also this same species as well as *P. rieli* and *P. rubescens* Stitz.

***Palpares latipennis* Rambur.**

Figure—Plate XVIII, Figure 1.

The fourth anal of f. w. has three or four branches and four or five cross-veins to the third anal. The third anal of h. w. is simple, with several cross-veins to the second and one or two to the fourth anal.

The *P. furfuraceus* of Walker (not of Rambur) is this species, Walker's identification of *P. cephalotes* is also this species. *P. prætor* Gerst. is this species.

***Palpares inclemens* Walk.**

Figure—Plate XVIII, Figure 5.

The third anal of h. w. runs into the second anal and with one or two cross-veins to fourth. The fourth anal of f. w. has three or four branches and four cross-veins to the third.

Sometimes the basal spot of hind wings is narrowly connected to the median. The wings especially the front pair are slightly sinuated on the outer margin.

**Palpares immensus** McLach.

Figure—Plate XIX, Figure 22, and Plate XXI, Figure 42.

Third anal of h. w. with a strong oblique cross-vein up to second, and a cross-vein behind to the fourth anal; fourth anal of f. w. with three or four branches and as many cross-veins; the third anal has but one fork.

*P. kalahariensis* Stitz is this species.

**Palpares cephalotes** Klug.

Figure—Klug; original description, and Plate XX, Figure 30 (*sollicitus*) and Figure 29 (*subducens*).

Third anal in h. w. simple, with two or three cross-veins to the second, and one to the fourth anal. No band under antennæ.

Walker's two species, *sollicitus* and *subducens* are *cephalotes* (as McLachlan has stated); the slight differences are only such as one finds in a series of many species of *Palpares*, *P. burmeisteri* Hagen (that is *P. cephalotes* Rambr) is probably the same species.

**Palpares karrooanus** Peringuey.

Figure—Peringuey, 1910, Plate VIII, Fig. 1.

Third anal in h. w. with one or two cross-veins to fourth anal; abdomen entirely reddish.

Although it has the hind wings almost wholly black as in *P. voeltzkowi* it is not related to that species, as all the marks are different; it is more nearly related to *P. radiatus*.

**Palpares oneilli** Pering. (*Golafrus*).

Figure—Peringuey, 1911, p. 35, Figure 4.

Navas has made a new genus for it on account of the excised basal margin of the fore wings, but this is probably found only in the male, otherwise the species is related to *P. radiatus*. It was described as a female, but the tip of abdomen appears broken and the very narrow wings are similar to those of male *immensus*.

**Palpares similis** Stitz.

Figure—Calvert, (1889), Plate X, Figure 1.

This species is related to *immensus* by the submarginal line in fore wing, but the median and stigmal bands of hind wings are broader behind than in front; there is a spot above the cubital fork; in both wings the apical marks are in the form of streaks.



**Palpares reticulatus** Stitz.

Figure—Navas, with original description (as *extensus*).

The third anal in h. w. has one cross-vein to the fourth anal. The description of Stitz seems to have the priority.

**Palpares obsoletus** Gerst.

Figure—Plate XX, Figure 43, and Navas (as *nebulo*).

The fourth anal of f. w. has three or four branches and two connections to the third; in h. w. the third anal is simple, with one or two cross-veins to the second and none to the fourth. There is a black band below the antennæ.

**Palpares normalis** Navas.

Figure—Navas, with original description.

I have not seen this species, but it appears to be good, so long as species are based on markings.

**Palpares geniculatus** Navas.

Figure—Navas (with description.)

I have not seen it, but apparently distinct.

**Palpares klugi** Kolbe.

Figure—Klug, Plate, Figure 3 (unnamed).

Fourth anal in f. w. with two branches and connected three times to third; the third in h. w. runs into second and then away, with a cross-vein before.

**Palpares tristis** Hag.

Figure—Hagen, Mozambique and Kolbe. Plate XXI, Figure 51, appendages.

The fourth anal in f. w. has two or three branches, and two or three cross-veins; the third anal in h. w. simple, with a somewhat oblique cross-vein to the second anal. Nearly always there is a spot beyond the cubital fork in the h. w.

The varieties *niansanus* Kolbe, and *brevifasciatus* and *ugandanus* of Stitz are structurally very similar to the type form, but *brevifasciatus* is perhaps closer to *interioris*.

**Palpares interioris** Kolbe.

Figure—Plate XXI, Figure 49.

The fourth anal of f. w. has two or three branches, and two, or three cross-veins; the third anal of h. w. is simple, with two connections to the second. The marks are very similar to those of *obsoletus*, but that species is larger than *interioris*, and the body markings somewhat different.

**Palpares lentus** Navas.

Figure—Plate XXI, Fig. 47, Navas, original description.

Third anal of h. w. simple, one cross-vein to the second, none to fourth anal. A black band below antennæ. Male appendages short, Fig. 36.

**Palpares pardaloides** Weele.

Figured by Van der Weele, Madagascar, Figure 5; also the male appendages on page 257.

Fourth anal of f. w. with four branches and two cross-veins; third anal of h. w. simple, no cross-vein to second. Legs deep black.

In the Brussels Museum is a long series from Madagascar that tends to connect this species to *P. insularis*.

**Palpares nigrita** Navas.

Figure—Plate XIX, Figure 27, and Navas, original.

Fourth anal in f. w. with two branches and two cross-veins; third anal of h. w. simple, and one straight cross-vein to the second anal. No band under antennæ.

*P. languidus* Navas appears also to go here, but the figure of the hind wing is broader than usual.

This is a species that stands in the Rambur collection with the label *P. manicatus* R., *P. tigris* Walk. var. *de tigris* Dalm, and also a label "Seneg" Rambur's *manicatus* according to him had two radial sectors like *tigris*, and with no locality label, so I cannot believe that this specimen is Rambur's type of *P. manicatus*. I figure the hind wing of this specimen, (figure 27).

**Palpares walkeri** McLach.

Figure—Plate XIX, Figure 21; Navas, Broteria X, p. 35.

Fourth anal of f. w. with two or three branches, and two cross-veins; third anal of h. w. simple, three or more cross-veins to second, and one to fourth. No band under antennæ.

*P. dispar* Navas seems to be the same species.

**Palpares angustus** McLach.

Figure—Plate XVIII, Figure 7.

Fourth anal in f. w. with three branches, and four cross-veins; third anal of h. w. has an oblique cross-vein to second and two cross-veins before it. Legs all deep black; the stigmal band of the hind wings sometimes has an upper inner projection. There is no band under antennæ.

The variety *oranensis* grades into the type.

**Palpares hispanus** Linn.

Figure—Navas, Insecta, 1911, p. 265.

The fourth anal of f. w. has one or two short branches and two cross-veins; the third anal of h. w. is simple, with an oblique cross-vein to second, but none to fourth. The marks on the abdomen (Fig. 33) are very characteristic; as in other species there is much variation in the extent of the marks on wings, and in the width of the hind wings.

***Palpares libelluloides* Linn.**

Figure—Many figures in European literature.

The fourth anal of f. w. is very short and curved, with one or two branches and one or two cross-veins. The third anal of h. w. is simple, with slightly oblique cross-vein to the second and none to the fourth anal.

*P. chrysopterus* Navas is the same or a slight variety.

***Palpares tessellatus* Rbr.**

Figure—Plate XX, Figure 32 (marks of abdomen), and Stitz (as *annulatus*).

The fourth anal of f. w. has two branches, and one or two connections; the third anal of h. w. is simple with one or two straight cross-veins. No dark band under the antennæ.

*P. annulatus* Stitz is a synonym of this species.

***Palpares percheroni* Guerin.**

Figure—Guerin, Iconog. Regn. Anim., Plate 62; Gray, Anim. Kingd., Plate 127, Figure 1.

The fourth anal of f. w. has two branches and one or no connection to third; the third anal in h. w. simple, with a somewhat oblique cross-vein to second anal. The male appendages are long and curved. The abdominal marks are figured on Plate XX, Figure 31.

***Palpares tigris* Dalm. (Nosa).**

Figure—Navas (*calceata*, *leonina*, *lupina*, *pardina*, and *hamatus*).

The fourth anal of f. w. has two or three branches and two or three connections to the third; the third anal of h. w. is simple, connected twice to the second and sometimes once to the fourth.

*P. manicatus* Rbr. is this species according to his description. *P. hamata* is a male. *P. tigris*, *calceata*, *hamata*, *sylphis* have quite large spots; *P. leonina*, *lupina* and *pardina* have smaller spots. Tip of fore wing, see figure 45.

***Palpares ægrotus* Gerst.**

Figure—Navas (as *longicornis*), Kolbe (as *submaculatus*), and Stitz (as *paucimaculatus*).

The fourth anal of f. w. with one or two branches and two connections to the third; third anal of h. w. simple, with one cross-vein to second, none to the fourth.

Variety *taborensis* Stitz is apparently the same. Tip of the fore wing, see figure 46. *P. dilatatus* Navas has stigmal spots united into a band.

***Palpares ornatus* Navas.**

Figure—Navas (with description).

Very close to *ægrotus* and perhaps a form of it, but the apical marks are different, and these in *ægrotus* seem very constant.

**Palpares speciosus** Linn.

Figure—Romer, Genera, Plate XXV, Figure 3; De Geer, Mem. III, Plate XXVII, Figure 9, (as *maculatus*); also Sulzer, Plate XXV, Figure 3.

The fourth anal of f. w. with two branches, and two cross-veins; the third anal of h. w. simple, with two cross-veins to second, but none to the fourth.

A peculiar variation in marking is seen on Plate XX, Fig. 37, hind wing; and male appendages Figs. 52, 53.

**Palpares dubiosus** Pering.

I have not seen this species nor is there any figure, but it is described as close to *P. speciosus*, so it is probably but one form of what will prove to be one common variable species.

**Palpares caffer** Burm.

Figure—Plate XXI, Figure 50.

The fourth anal of f. w. with two branches and two cross-veins to third; the third in h. w. simple, with one cross-vein to the second, but none to the fourth.

The difference between this and *P. speciosus* is hardly sufficient for a species, and not constant; the wings are usually shorter than in *P. speciosus*, and the fore pair less heavily marked.

**Palpares varius** Navas.

Figure—Navas, original description.

In fore wing the fourth anal has two branches and two connections; in hind wings the third anal is simple with two connections to second, but none to fourth.

**Palpares digitatus** Gerst.

Figure—Calvert, Figure 3 (unnamed); Navas (as *torridum* and *pobeguini*); and Plate XIX, Figure 24.

In fore wing the fourth anal has one branch and one cross-vein. Third anal in h. w. simple, not connected to fourth anal, with two veinlets to the second anal.

The figure I give and that of Navas represent heavily marked specimens; that of Calvert is more normal. I think *P. umbrosus* Kolbe is the same; but the bands are narrower and one or more "fingers" are usually separate from the bands, and the wings may be a little more slender, in fact it is more like *P. speciosus*, and appears to connect *speciosus* with *digitatus*. The hind wings of typical *umbrosus* are shown in figure 44.

***Palpares stuhlmanni* Kolbe.**

Figure—Kolbe, Figure 1.

Closely related to *P. speciosus*, at least in the male appendages; the marks are similar to those of *P. umbrosus*; the venation is as in *P. speciosus*

***Palpares damarensis* McLach.**

Figure—Plate XVIII, Figure 11, and Stitz (as *bifasciatus*).

Fourth anal in f. w. with two or three branches and two cross-veins; third anal of h. w. simple, no connection to the fourth. Black hair on clypeus; legs all black; head all dark, except pale clypeus.

***Palpares formosus* Banks.**

Figure—Plate XIX, Figure 23; also Navas in Broteria X, p. 85, Figure 16.

Fourth anal in f. w. with one short branch, and one cross-vein; third anal of h. w. simple with one cross-vein to second and none to the fourth.

***Palpares festivus* Gerst.**

Figure—Peringuey (as *mosambicus*), and Navas (as *latro*).

The third anal of h. w. simple, and no cross-vein to the fourth. Legs black.

***Palpares elegantulus* Pering.**

Figure—Peringuey 1910, Plate VII, Figure 4.

This small slender-winged species is apparently very distinct; I have not seen it, but it appears related to the *flavofasciatus* group.

***Palpares flavofasciatus* McLach.**

Figures—Peringuey (as *genialis*); Stitz (as *guttatus*); and Navas (as *nyassensis*)

The third anal in h. w. is simple and no connection to the fourth anal. Legs black.

In *P. nyassensis* the bands are a little wider than in the other types, but a series of specimens shows much variation in this point.

***Palpares compositus* Navas.**

Figure—Navas (and also as *mistus*).

Closely related to *flavofasciatus*, but with the bands of hind wings much broader and connected. *P. mistus* Navas appears to be the same form. It is in the Berlin Museum under a manuscript name that I cannot find has ever been published.

***Palpares bifasciatus* Oliv.**

Figure—Plate XVIII, Figure 6.

Fourth anal in f. w. with two branches, and two cross-veins; the third anal of h. w. simple, connected about four times to the second and twice to the fourth. A broad black band under antennæ; abdomen pale yellowish red; thorax with two rows of yellow spots.

This was considered by Walker as *P. pardalinus* Burm. McLachlan doubted it, and so named Walker's insect *P. brachypterus*; but Hagen (who saw both) asserts that Walker's insect is *pardalinus* B. It agrees with the *Mymeleon bifasciatum* Olivier.

**Palpares spectrum** Rambur.

Figure—Navas, Rev. Zool. Afric., II, p. 37.

The fourth anal of f. w. has two branches and two connections; the third anal of h. w. is simple, with one cross-vein to second, but none to fourth anal.

**Palpares rothschildi** Weele.

Figure—Stitz, Figure 10.

The fourth anal in f. w. has two branches and two connections; the third anal in h. w. is simple, and one cross-vein to second anal.

Very closely related to *P. spectrum* and probably but a local variety, occurring northward of the range of *P. spectrum*.

**Palpares ovampoanus** Pering.

Figure—Peringuey, 1910, Plate VII, Figure 1.

This is closely related to *P. spectrum* and will fall in the subgenus *Palparellus*. I have not seen specimens in European collections.

**Palpares translatus** Walk.

Figure—Plate XVIII, Figure 13.

The third anal in h. w. is simple, and not connected to the fourth anal. Antennæ close together at base; subcosta not thickened, but in general structure is closely related to *Pamexis luteus*.

**Palpares luteus** Thunberg. (*Pamexis*).

Figure—Plate XVIII, Figure 9.

The third anal in h. w. is simple, and connected once to the fourth anal.

*P. venosus* Burm. is the same; and Hagen asserts (and he has examined both types) that *P. conspicuatus* Burm. is also the same species. The subcosta is thickened in both sexes, otherwise the species is related to *P. translatus*. There are specimens in the Berlin, Brussels and British museums.

**Palpares contaminatus** Hagen.

Figure—Plate XVIII, Figure 4.

This name was given by Hagen (Can. Entom. 1887, p. 112) for *P. pardalinus* Rambur, not of Burmeister. I figure the hind wing of the type. The subcosta of fore wing is not thickened.

## INDIAN SPECIES.

1. A large spot over the fork of the cubitus in the hind wing.....6.  
No such spot.....2.
2. An elongate spot along middle of hind margin of hind wing; median band does not reach across.....*tigroides*  
No such spot; median reaches across.....3.
3. Fore wings mostly dark, leaving only large and small pale spots, rather small species.....*astutus*  
Fore wings, mostly pale, with dark bands or spots.....4.
4. Margin of fore wings plainly sinuate; some bands of both wings reach across; large species.....5.  
Margin of fore wings not sinuate, bands of fore wings not across; hardly across in the hind wings.....*papilionoides*
5. Tips of hind wings plainly falcate; stigmal band without projection toward median band.....*falcatus*  
Tips not falcate; stigmal spot with projection toward the tip of the median band.....*contrarius*
6. Two parallel stigmal bands, or spots.....7.  
But one stigmal band, or broken into one series of spots.....9.
7. Both median and stigmal bands in hind wings reach across.....8.  
Neither median nor stigmal reach across; margins of both wings narrowly dark.....*astarte*
8. Median connected to basal spot; latter reaching across hind wing...*patiens*  
Median not connected to the basal, which does not reach across...*infirmus*
9. Apical mark of hind wings solid; stigma very broad and reaches across...*solidus*  
Apical mark with spots, or broken; stigmal band not very broad nor reaching across.....10.
10. A spot behind radius above the basal spot on the cubital fork of the hind wings; stigmal mark running obliquely inward.....*zebratus*  
No spot behind radius; stigmal band extending outward, or curved inward...*pardus*

*Palpares astarte* n. sp.

Figure—Plate XIX, Figure 18.

Head yellowish; a row of pale hairs across clypeus, and on margin of labrum; a black spot narrowing behind on vertex, continued over thorax as a median stripe, widest on the mesothorax, dark stripe on sides of pronotum, and stripe on meso and metathorax over base of the wings; abdomen yellowish brown, a black spot on apex of the first segment; legs and sternum all black. Wings rather yellowish, and with yellowish venation; costa black, and with black points out on costals, but costals are pale; outer posterior margin of both pairs of wings dark brown; fore wings with five series of spots; a long streak on cubitus broader at tip and bending down; a spot above it behind the radius; an oblique band beyond the streak reaching from radius to more than one-half way across; beyond this are two spots in an oblique row; then three spots in a transverse row, one stigmal, the other two in form of streaks; the two subapical marks are not quite streaks. In hind wings is a spot on cubital fork, a band beyond reaching to beyond middle where it is enlarged; a curved band beyond this, not reaching either radius or hind margin, larger behind; then two large spots, one stigmal, the other close behind it; then a sinuous band before apex. Wings of moderate breadth; in fore wing the third anal is connected to the fourth four or five times, in hind wings the third anal has an oblique vein running into the second anal, and one cross-vein beyond it. Expanse 125 mm.

From Chapra, Bengal, India (Mackenzie).

**Palpares pardus** Rambr.

Figure—Plate XVIII, Figure 3, and anal appendages, Plate XXI, Figure 54.

The fourth anal of f. w. has three or four branches and three cross-veins; the third anal in h. w. is simple, with two cross-veins to second.

*P. expertus* Walk is the same species; it is very common in India.

**Palpares zebratus** Rambr.

Figure, Plate XX, Figure 28.

The third anal of h. w. simple, with two to four cross-veins to second and one to three to fourth anal. Abdomen with a median dark stripe above. The fore wings are without distinct bands, but with median and stigmal spots.

**Palpares contrarius** Walk.

Figure—Plate XVIII, Figure 8.

The third anal of h. w. simple, with two cross-veins to the second, one of which is slightly oblique, in the f. w. the fourth anal has two branches and two or three connections.

This is a beautiful species not uncommon in Ceylon. In Walker's description a line is omitted regarding the second band in the hind wings, for it is this band that has a projection toward the first band.

**Palpares falcatus** McLach.

Allied to *contrarius* in markings, but hind wings more falcate; I have seen only the type.

**Palpares patiens** Walk.

Figure—Plate XVIII, Figure 10, and Navas in Broteria X, p. 86, Figure 17.

The third anal of h. w. runs into the second, and a cross-vein behind to fourth anal; abdomen dark, unmarked.

**Palpares infirmus** Walk.

Figure—Plate XVIII, Figure 12.

The third anal of h. w. with an oblique vein to the second, one cross-vein before it to second, and one behind to fourth anal. No band under antennæ.

This is probably the same species as *P. patiens*. Fore wings with many spots, and streaks and spots along the outer hind margin, stigmal and median bands small.

**Palpares papilionoides** Klug.

Figure—Klug, Plate, Figure 2.

The third anal in h. w. is simple, no cross-vein before the oblique one running into second.

It is not common and is represented in but few European collections.



***Palpares solidus* Gerst.**

Figure—Plate XIX, Figure 20; and Navas (as *klapaleki*).

The fourth anal in f. w. is two or three branched, and with two of three connections; the third anal in h. w. is simple, with one cross-vein to second.

***Palpares tigroides* Walk.**

Figure—Plate XX, Figure 34.

Third anal of h. w. simple, one cross-vein to the second and none to fourth anal. Legs black; fore wings with hardly any marks, rather yellowish.

***Palpares astutus* Walk.**

Figure—Plate XIX, Figure 19.

The fourth anal of f. w. with two branches, and two cross-veins; the third anal of h. w. simple, with one cross-vein to second. It belongs to the subgenus *Palparellus*.

## STENARES.

(including *Crambomorphus*.)

1. Outer margin of wings strongly sinuate.....(*Crambomorphus*) 2.  
Outer margin of wings not plainly sinuate.....(*Stenares*) 3.
2. Hind wings pale with two large bands well separated, and apex marked....  
*grandidieri* Weele.  
Hind wings with the bands so large they are connected and cover most of surface, leaving only pale spots.....*sinuatum* Oliv.
3. Hind wings with all the bands broad and connected, leaving only pale spots...  
*madagascariensis*.  
Hind wings not so heavily marked.....4.
4. No stigmal spot in hind-wings, a streak along outer edge, and sometimes a few dots before it; wings very narrow; in hind wings costals at base are crossed.  
*hyaena*.  
A stigmal spot reaching nearly one-half way across.....5.
5. A spot on hind wings just beyond the cubital fork, also large median band; wings broad; in hind wings the costals are mostly simple.....*irroratus*.  
No spot on hind wings near the cubital fork, but median spots (or band) are sometimes present; in the hind wings the costals are mostly crossed....6.
6. Larger; apical mark of the hind wings in the form of two streaks....*improbus*.  
Smaller; apical mark of the hind wings entire, or partly broken, not in form of streaks.....*harpyia*.

In *S. hyaena*, *irroratus*, *improbus* and *harpyia* the third anal of h. w. runs into the second, with one or three cross-veins before; all have a pale pronotum with a median black stripe, and all have black legs.

***Stenares (Crambomorphus) grandidieri* Weele.**

Figure—Weele, Madagascar, Fig. 2.

Differs much in markings from *S. sinuatus*; fully half of the hind wing is hyaline; the wings are also much broader than in that species, but the hind wing shows the same costal swelling at apex. The anal venation is similar to that of *S. sinuatus*, but in the h. w. the third anal has but one cross-vein to the fourth anal.

**Stenares (Crambomorphus) sinuatus** Oliv.

Figure—Plate XIX, Fig. 14.

Hind wings black; two pale spots in middle and stigma pale, and pale spots on hind border.

Fourth anal in f. w. has four branches and four connections; in h. w. the third anal is long, with an oblique cross-vein to the second and others nearly erect, and four cross-veins to the fourth anal.

*Palpares hæmatogaster* Gerst. is the same species.

**Stenares irroratus** Navas.

Figure—Navas, original.

I have seen only the type in the British Museum.

**Stenares improbus** Walk.

Figure—Plate XIX, Figure 16, and male appendages, Figure 25.

In h. w. the third anal runs into the second, and has two cross-veins to fourth; in f. w. the fourth anal has five branches and five cross-veins to the third.

**Stenares harpyia** Gerst.

Figure—(Anal appendages) Plate XIX, Fig. 26.

The fourth anal of f. w. has many branches and many connections to the third anal; in h. w. the third anal runs into the second, and has two branches.

**Stenares madagascariensis** Weele.

Figure—Van der Weele, Madagascar, Fig. 1.

The third anal of hind wing is simple, with an oblique cross-vein to second and two or three before it, and four or five cross-veins to the fourth.

**Stenares hyæna** Dalman.

Hagen considers the figure 12, plate 86, of the Fourth volume of Seba's *Thesaurus* as representing the species.

## EXPLANATION OF PLATES XVIII TO XXI.

- Fig. 1. *Palpares latipennis*, hind wing.  
 Fig. 2. *Palpares incommodus*, hind wing.  
 Fig. 3. *Palpares pardus*, hind wing.  
 Fig. 4. *Palpares contaminatus*, hind wing.  
 Fig. 5. *Palpares inclemens*, hind wing.  
 Fig. 6. *Palpares bifasciatus*, hind wing.  
 Fig. 7. *Palpares angustus*, hind wing.  
 Fig. 8. *Palpares contrarius*, hind wing.  
 Fig. 9. *Pamexis luteus*, hind wing.  
 Fig. 10. *Palpares patiens*, hind wing.  
 Fig. 11. *Palpares damarensis*, hind wing.  
 Fig. 12. *Palpares infirmus*, hind wing.  
 Fig. 13. *Palpares translatus*, hind wing.  
 Fig. 14. *Stenares sinuatus*, hind wing.  
 Fig. 15. *Palpares moestus*, apex of hind wing.  
 Fig. 16. *Stenares improbus*, hind wing.  
 Fig. 17. *Palpares gigas*, apex of hind wing.  
 Fig. 18. *Palpares astarte*, fore and hind wings.  
 Fig. 19. *Palpares astutus*, fore and hind wings.  
 Fig. 20. *Palpares solidus*, hind wing.  
 Fig. 21. *Palpares walkeri*, hind wing.  
 Fig. 22. *Palpares immensus*, hind wing.  
 Fig. 23. *Palpares formosus*, hind wing.  
 Fig. 24. *Palpares digitatus*, hind wing.  
 Fig. 25. *Stenares improbus*, male appendage.  
 Fig. 26. *Stenares harpyia*, male appendage.  
 Fig. 27. *Palpares nigrita*, hind wing.  
 Fig. 28. *Palpares zebratus*, hind wing.  
 Fig. 29. *Palpares subducens* hind wing.  
 Fig. 30. *Palpares sollicitus*, hind wing.  
 Fig. 31. *Palpares percheroni*, abdomen.  
 Fig. 32. *Palpares tessellatus*, abdomen.  
 Fig. 33. *Palpares hispanus*, abdomen.  
 Fig. 34. *Palpares tigroides*, hind wing.  
 Fig. 35. *Palpares latipennis*, and *amitinus*, anal area of fore wings.  
 Fig. 36. *Palpares lentus*, male appendages.  
 Fig. 37. *Palpares speciosus*, variation of hind wing.  
 Fig. 38. *Palpares insularis*, anal area, fore wing.  
 Fig. 39. *Palpares inclemens*, anal area, hind wing.  
 Fig. 40. *Palpares radiatus*, male appendages.  
 Fig. 41. *Palpares umbrosus*, male appendages.  
 Fig. 42. *Palpares immensus*, male appendages.  
 Fig. 43. *Palpares obsoletus*, hind wing.  
 Fig. 44. *Palpares umbrosus*, hind wings, of two males.  
 Fig. 45. *Palpares tigris*, apex of fore wing.  
 Fig. 46. *Palpares aegrotus*, tip of fore wing.  
 Fig. 47. *Palpares lentus*, hind wing.  
 Fig. 48. *Palpares extensus*, hind wing.  
 Fig. 49. *Palpares interioris* hind wing.  
 Fig. 50. *Palpares caffer*, hind wing.  
 Fig. 51. *Palpares tristis*, male appendage.  
 Fig. 52. *Palpares speciosus*, male appendage, side.  
 Fig. 53. *Palpares speciosus*, male appendage, above.  
 Fig. 54. *Palpares pardus*, male appendage.  
 Fig. 55. *Palpares moestus*, male appendage.

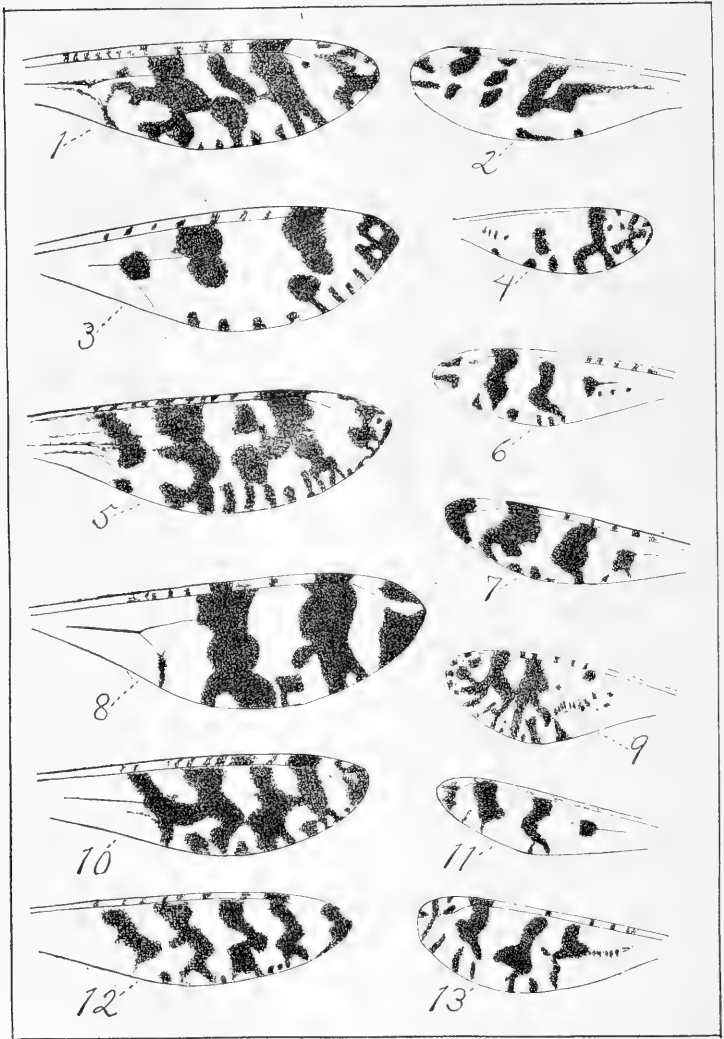

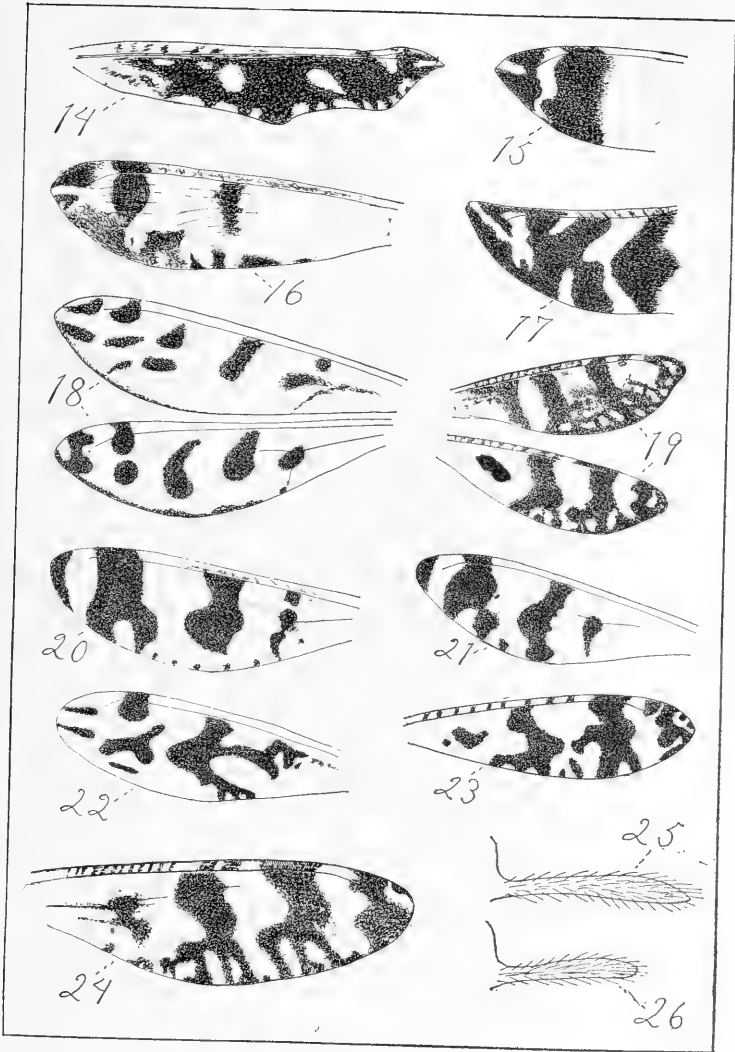

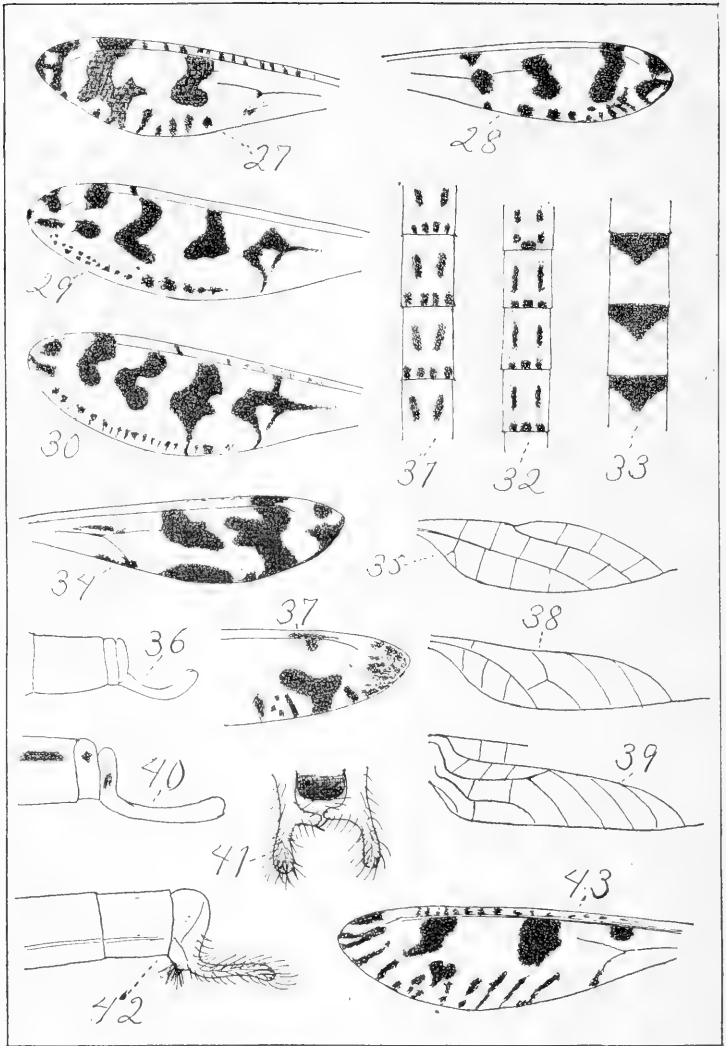

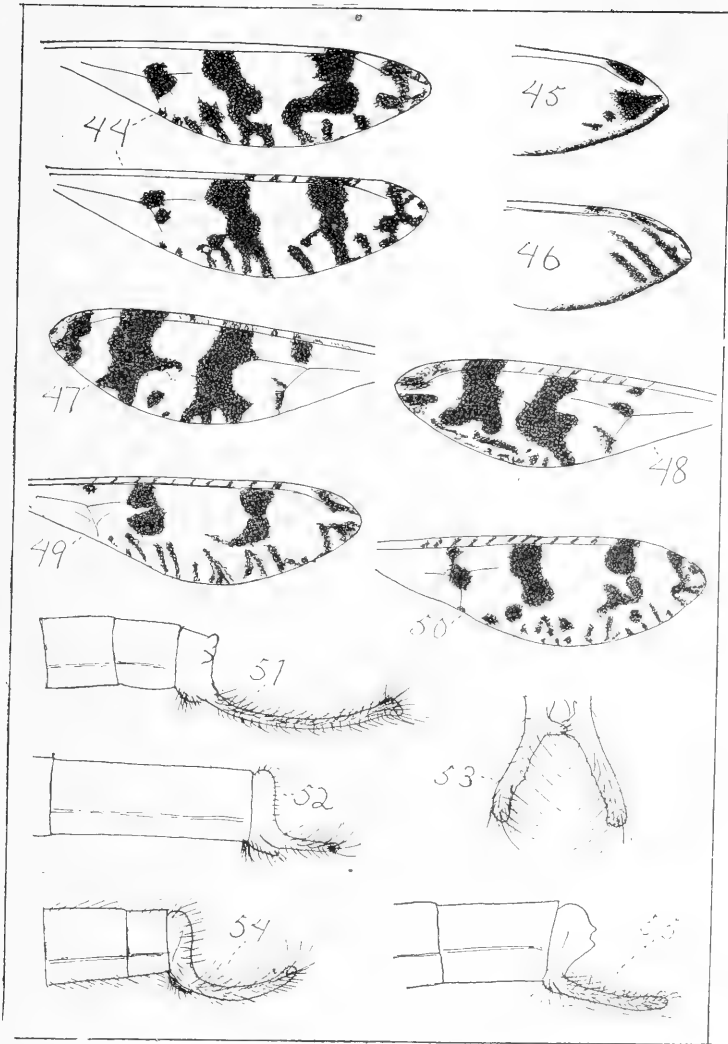

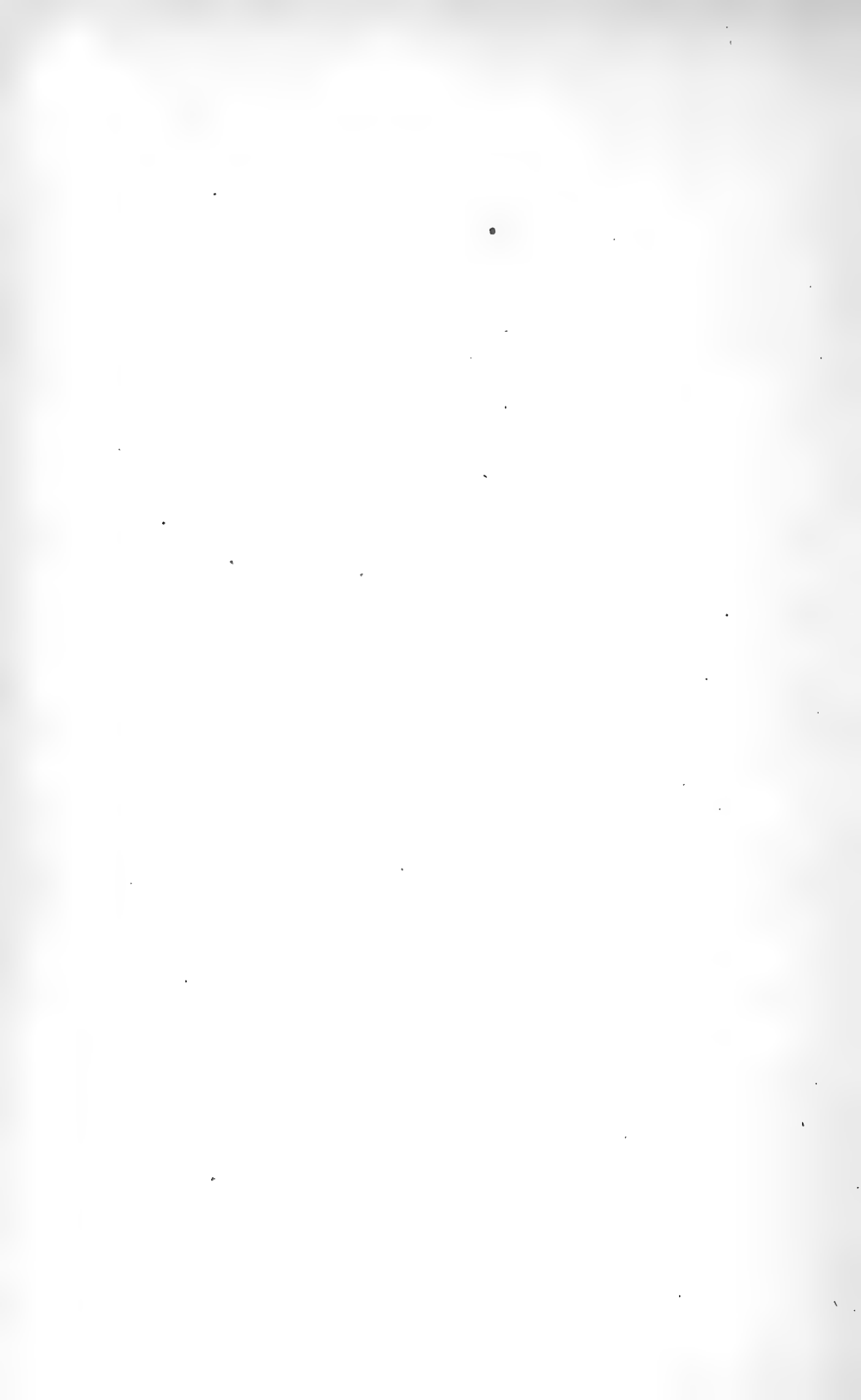



## STOMOXYS CALCITRANS LINN, PART II.\*

By CHAS. K. BRAIN.

### *The Circulatory System.*

The circulatory system in *Stomoxys calcitrans* consists, as in other Diptera, of the dorsal vessel or heart, and its anterior continuation, the thoracic aorta. The dorsal vessel extends as a delicate tube from the posterior part of the abdomen to its anterior sixth, that is above the anterior part of the sucking stomach, where it becomes narrowed into the thoracic aorta. This narrowed portion continues of uniform thickness until the proventriculus is reached, where it becomes somewhat flattened and wider. Beyond this it becomes narrower, and terminates above the esophagus, between the proventriculus and the neck.

It may be noticed that, as found by Professor Minchin in his study of *Glossina* sp., the dorsal vessel ends blindly behind, is composed of similar giant cells, and has similar ostia and alary muscles. The number of chambers in the heart was not determined with certainty, but I think Tulloch was correct in supposing that there were four. The dorsal vessel lies free in the pericardial cavity, but is supported by the muscular pericardial septum.

### *Nervous System.*

There are two chief ganglia, viz: the brain and the thoracic ganglion, and from these the main nerve-trunks arise. Time was not taken to work out the more minute nerves, but the following may be mentioned. The chief nerves of the head beyond those of the compound eyes, are those which enervate (a) the antennae, (b) the ocelli, and (c) the esophagus, pharynx, and the pharyngeal muscles.

The brain is connected with the thoracic ganglion by commissures, between which the esophagus passes. The thoracic ganglion is roughly pear-shaped, and is supported by the internal chitinous skeleton of the thorax. The main nerves given off from the thoracic ganglion are (a) six pairs which

\*The first part of this paper, which dealt with the external mouthparts and the digestive system, appeared in Vol. V, No. 4, pp. 421-430 of these ANNALS, December, 1912.

supply the thoracic muscles, and (b) the abdominal nerve trunk, which arises as a stout continuation of the posterior part of the ganglion. This nerve trunk gives off fine branches to the abdominal muscles and on reaching the third abdominal segment, splits into three.

These three branches supply the reproductive organs, the ovaries or testes, and the ovipositor or the penis.

#### *Reproductive System.*

The male generative organs, (Plate XXII, Fig. 7.) are comparatively simple in structure. They are however not readily seen in gross dissection until some of the surrounding and over-lying Malpighian tubules are moved. They consist of a penis, ejaculatory duct, vesicula seminalis, and testes with their ducts.

The testes are smooth, spherical bodies, enclosed in sacs which have deeply pigmented walls, giving them a deep orange color. From the lower end of each testis a delicate tube arises, short and straight, which runs down to join the duct from the opposite side, as the upper limbs of a Y.

From this junction an exceedingly short length of common duct enters the bulbous upper end of the tubular organ, which would seem to serve as a vesicula seminalis. This is a flexible tube, often seen lying with one or two U-shaped bends in its course. At its upper end this vesicula seminalis is bulbous, gradually narrowing below to form the ejaculatory duct, (Fig. 7, e. d.), which crosses the rectum dorsally from left to right, to enter the penis in front of it.

The female reproductive organs, (Pl. XXII, Fig. 8) are of the house fly type. There are two ovaries, each consisting of some 60 ovarioles. The ovaries vary in size according to the degree of maturity of the lowest ova, of which there are never more than four in a single ovariole. In some cases the ovaries occupy more than half of the whole abdominal space. The ovarioles from one side open into a wide tubular duct which joins the similar duct from the other side like the arms of a Y.

As a result of this junction a common oviduct (o. v.) results, which runs down forming a long third limb to the Y. Below the attachment of the uterine appendages the oviduct continues as the uterus. The appendages consist of the uterine glands and the receptacula seminis.

The uterine glands, (u. g.), are two rather stout tubular organs with slightly bulbous extremities. The bulbous end is firmly joined to the lateral oviduct by a very short double strain of connective tissue.

The receptacula seminis are two small, black, spherical bodies, each with a cellular socket resembling the fitting of an acorn cup. From this runs a very fine duct which enters the division between the oviduct and the uterus in the mid-dorsal line. The receptacula are attached to each other but can be separated by dissection. The uterus is a tube of the same diameter as the common oviduct above, and runs down the middle line into the ovipositor.

The ovipositor consists of three cylindrical segments of thin chitin which usually lie telescoped inside the abdomen.

#### *Habitat.*

Farmyards and stables are evidently the favorite haunts of this fly. It occurs also in fields and open woods, especially where cattle or horses are grazing. It is evidently by no means uncommon even in large cities, and numbers have been seen in quite busy streets. It is fond of resting on surfaces fully exposed to the sun, such as doors, gates, and rails, and to a less extent also on stone walls. Painted surfaces seem to be specially attractive to it. Its flight is quite inaudible at a short distance. When disturbed it frequently returns to the same spot, as though it were a favorite resting place. It is quite active during the warmer part of the day, and at night returns to some sheltered spot such as the beams in a shed. In Columbus the numbers of this species dwindled towards the end of October in 1912, but a few could be caught up to the end of November, and four specimens were taken on December 3rd. In captivity these flies live but a short time, generally less than a week. They frequently clean their wings, performing their cleaning with great precision, the hind pair of legs being used for this purpose. The lower surface is combed, then the upper, the legs are then rubbed together and the process repeated.

#### *Emergence from the egg.*

The larva makes its escape from the egg by splitting the broad end of the groove, leaving it slightly raised, and apparently intact on the opposite side, Plate XXII, Figure 1.

*The Larva.* Plate XXII, Figs. 2 and 3.

Color creamy white to yellowish, shiny, greasy in appearance. The coiled alimentary tract, when filled with food, gives the posterior portion a dark appearance. The longitudinal tracheae may be recognized as two submedian white lines which show delicate lateral branches. The posterior stigmata are black, while the thoracic ones are yellowish in color.

In form the larva is elongate, tapering towards the head but broadly rounded behind. The segmentation is not very conspicuous, and the epidermis is bare, not having hairs nor bristles. On the head may be seen two large divergent mammiform processes, at the end of which are the minute retractile antennae, which are apparently each composed of four subequal segments. The mouth parts are strongly chitinised in the full grown larva and are composed of a number of sclerites as shown in Figs. 2 and 3.

The last seven segments are furnished, on their ventral surface, with raised bands of tactile tubercles. The posterior stigmata are two in number, circular, and somewhat distant from each other. The thoracic stigmata occupy a sub-lateral position on the third segment, and each consists of five circular orifices. (t. s.). These are connected with a large bilateral air sac which extends along the fourth segment.

*Method of pupation.*

The time taken for pupation is usually about two hours. The larva at first becomes quiet, and shortens rapidly, chiefly by the contraction of the anterior segments. In this way it assumes a form which resembles a barrel in shape. At this stage it is still yellowish white and the mouthparts of the larva are plainly visible through the soft integument. The color then changes to a bright yellow, and in about an hour longer it assumes the normal chestnut color of the puparium.

The puparium is from 5 to 6 mm. in length, only eleven segments are visible, the anterior one bearing the minute, bilateral, thoracic stigmata, while the broadly rounded posterior segment shows the disc-like posterior stigmata. Under optimum conditions this stage lasts from 9 to 13 days.

*Development of the adult.*

About three days before the emergence of the adult fly, the cuticle of the puparium darkens, and eventually splits along the lateral and median lines, anteriorly, and trans-

versely across the fourth segment. This section falls away and the fly escapes. Prior to this the nymph undergoes its final ecdysis, pushing its effete skin off backwards into the posterior end of the puparium. On its emergence it appears as a small dark fly, gray in color, with thick rudimentary wings of a dull leaden color. Its head is, at this stage, much wider than the thorax, and the abdomen is attenuated. At first it is very active, the period of activity evidently serving to allow the fly to force its way to the surface before the wings are fully grown and stiffened. The frontal sac is constantly inflated during this time, and no doubt serves in moving fragments of earth, etc. out of the way. When liberated the insect spends considerable amount of time in combing out the hairs on the arista of the antennae.

During this time the fly constantly changes its position, and the frontal sac is contracted. There are marked changes, too, in the abdomen and wings. The abdomen first becomes longer, and is constantly expanded and contracted, and gradually assumes its normal coloring, with the clove spots. The wings then begin to expand, a process which is completed in less than five minutes.

The fly is about its normal size, shape, and color at this time, but some time is taken in the final hardening of the integument, and in the final combing operations, which seem to be indispensable before flight. It is during this last process that the proboscis is at last raised into its horizontal position.

#### REFERENCES.

- See Bibliography given in Part I, and also:  
 NEWSTEAD, R. 1907. *Stomoxys calcitrans* Linn. Ann. Trop. Med. and Parasit. Vol. I. 1907. Liverpool.

#### DESCRIPTION OF PLATE XXII.

- Fig. 1. Egg, greatly enlarged, showing groove, and point of emergence of the larva, *e*.  
 Fig. 2. Lateral view of anterior segments of larva, showing *ant*, antenna; *m*, mandible; *h. s.*, hypostomal sclerite.  
 Fig. 3. Dorsal view of anterior segments of larva of *Stomoxys calcitrans*. *m*, mandible; *t. s.*, thoracic spiracle.  
 Fig. 4. Openings of thoracic spiracle.  
 Figs. 1, 2, 3 and 4. After Newstead.  
 Fig. 5. Semi-diagrammatic view of adult fly. See Part I.  
 Fig. 6. Salivary glands and left Malpighian tube of adult, see Part I.  
 Fig. 7. Male reproductive organs: *t*, testis; *v. s.*, vesicula seminalis; *e. d.*, ejaculatory duct; *r*, rectum.  
 Fig. 8. Female reproductive organs: *o*, ovary; *ov*, oviduct; *u. g.*, uterine gland; *u*, uterus; *r. s.*, receptacula seminis.

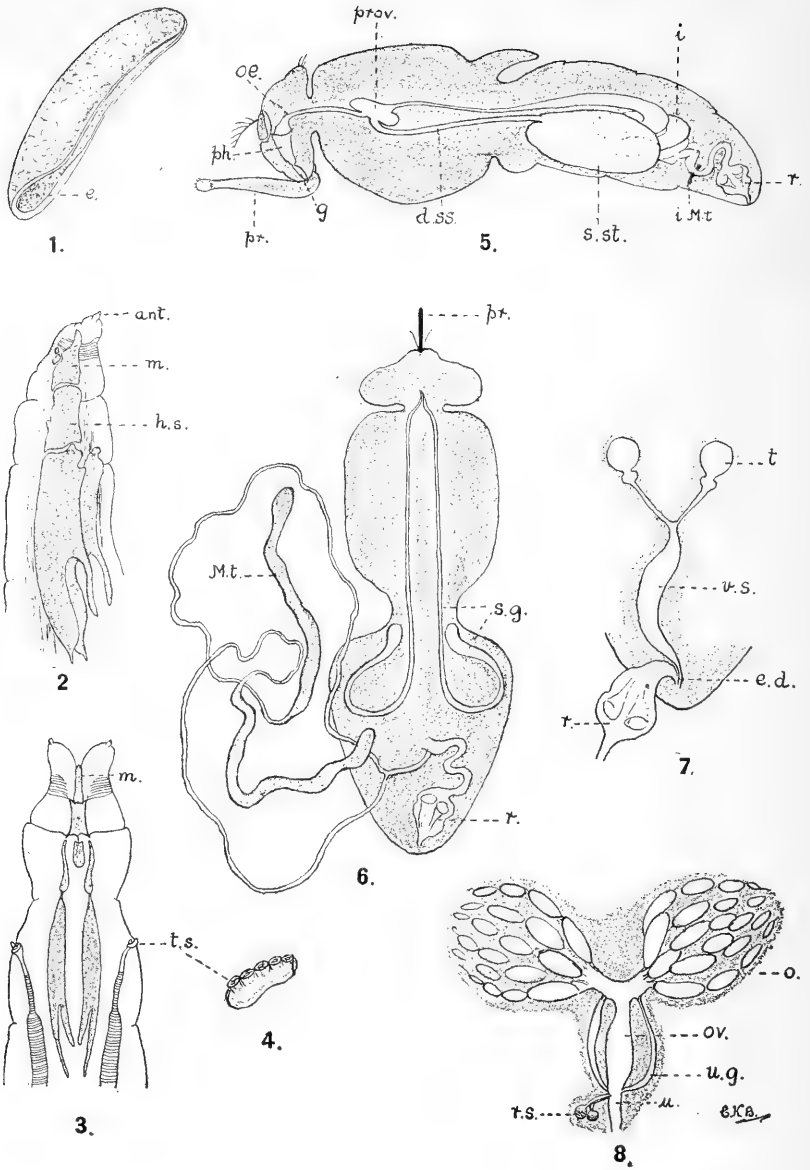

# THE BIOLOGY OF PERLA IMMARGINATA SAY.\*

By LUCY WRIGHT SMITH.

*Introduction.* Perhaps less is known concerning the life-histories and habits of the Plecoptera than of any other group of aquatic insects. Hence a more extensive knowledge of stone-flies along biological lines is desirable. At the suggestion of Professor James G. Needham such a study was commenced at Ithaca in the fall of 1910.

This locality with its many creeks and spring brooks is an excellent collecting ground for Plecoptera, and the equipment of the limnological laboratory of Cornell University makes an intensive study of aquatic forms possible. The essential factor in rearing stone-flies, as in many other stream-inhabiting insects, is running water. This is provided by a series of taps in a roof garden aquarium and also in a small artificial pond out of doors.

*Methods.* With the hope of obtaining truer results by keeping conditions as natural as possible, most of this study is being carried on out-doors. Some care must be taken in transporting stone-fly nymphs from the stream to permanent quarters. Full grown nymphs can breathe air directly, and have been carried most successfully wrapped in a wet cloth or packed in damp moss. Smaller nymphs can be taken safely for short distances in collecting jars full of clean, cold water.

In the artificial pond the nymphs are kept, eight to ten together, in cylindrical cages made of galvanized wire screen with cheese cloth covers. For small nymphs it is necessary to have the lower part of the cage lined with cloth. The cages are partially submerged in the current near the taps. With flat stones and bits of water weed in the bottom, and a steady flow of water, the nymphs can live a natural life.

The shyness of adult stone-flies makes field observations at close range impossible. Consequently they are kept in screen cages of about two by three feet. Here again an imitation of natural environment is attempted. This is done by keeping green twigs, clumps of sod, stones and pans of water in the cages.

---

\*Contribution from the Limnological Laboratory of Cornell University.

Although these pans of water are but a poor imitation of streams they suffice for most purposes. Better aerated water is necessary, however, for development of eggs. For this reason they are kept in running water in test-tubes closed at either end with fine silk bolting-cloth.

#### *Nymph.*

*Habitat.* This introductory paper includes only the observations made in June, July and August of the past summer, upon a single species, *Perla immarginata*. The nymphs occur in moderate numbers in all the larger streams about Ithaca, and very abundantly in the spring brook at Coy Glen. This abundance may be accounted for by the fact that there is less competition for a livelihood in this stream. *Perla immarginata* reigns supreme at the height of its season, the middle of July, not only as the largest of the stone-flies, but of all the aquatic insects. In the other streams are several competitors of equal size and strength and many more enemies.

Early in the spring, torrents of water rush through the glen, but in July and August the brook is reduced to a shallow stream. The high walls and the narrow, winding course of the gorge shut out so much sun-light that in spite of its shallowness, the water is always cold. Much of the stream bed is shale, free from sand and gravel, but well covered with a diatomaceous ooze. Here the water flows in a thin sheet. In other places are deeper pools strewn with clean, coarse gravel. Stones of all shapes and sizes are scattered along the stream. At this season, most of the stones, even the flat ones on the rocky bed, are partly out of water. Generally these are the haunts of stone-fly nymphs just before emergence.

*Neighbors and enemies.* These same stones shelter other creatures, fragile may-fly nymphs, chironomid larvae partially concealed in their slime tubes, and caddis worms standing guard behind their seines. Nearby on the rough floor of the stream hang the last stragglers of the mats of black fly larvae. In crevices on all sides lurk cray-fish, less welcome neighbors.

*Occurrence.* Late in June an occasional sprawling, nymphal skin clinging to the upper surface of a stone fortells the approach of the season for *Perla immarginata*. About three weeks later the casts are very numerous, and the overturning of a single stone sends a whole colony of the tiger-striped nymphs scampering in all directions in search of hiding places.



*Length of Nymphal Life.* It is evident at a glance that these nymphs are not all of the same size or stage of development. They fall into three groups. One contains very few individuals, these are small immature nymphs not more than half an inch in length. The second group, also a small one, is made up of nymphs about three quarters of an inch long. These are immature too, but older than first, larger and with small wing pads. The mature nymphs with their black wing pads form the largest group.

As far as is known, the complete life-history of no stone-fly has been worked out. Therefore we can only speculate concerning the length of it, knowing of course that whatever it may be, by far the greater part is spent in the nymphal stage. From the brief period of incubation of the eggs of some of the smaller individuals of the group, *Capnia* for example, and from the appearance of mature nymphs only at the emerging season, it seems probable that the life-history of these is completed in a year. On the other hand, the three groups of nymphs of different size in *Perla immarginata* and allied species, seem to indicate, as in some of the larger may-flies, a longer period, probably three years. Just where the nymphs live when it is not the transformation season, is not known.

*Adaptations.* A closer examination of the mature nymph shows that there are no external sexual characters. Nevertheless, the females can be easily separated from the males because the dark brown eggs show through the sides of the abdomen. In addition, as one would expect, the males are smaller; they vary from three quarters of an inch to an inch in length. The females have the same degree of variation, the largest being about an inch and a quarter in length and the smallest a little less than an inch. The color pattern of the nymph, black banded with white or pale yellow, and snowy white tufts of the tracheal gills on the thorax behind and above each leg, would make them rather conspicuous if they lived in the open. (Figs. 3 and 4).

The form of the nymph—flat-bodied, with flat, sprawling legs, and tarsi armed with two strong claws—is strikingly adapted for clinging. The legs are fringed with long hairs, which make them useful in swimming as well as running, and one need only disturb the nymphs to see how swiftly they can escape by either method. The shyness of stone-fly nymphs, their splendid

adaptations for clinging, running and swimming make their existence fairly easy, especially in this stream where the crayfish is the only enemy of any account.

*Food Habits.* The long standing supposition that stone-fly nymphs devour their weaker neighbors, has been confirmed for this species in a study of their food habits. This has been done by examining the stomach content of nymphs taken from the stream, and also by feeding those in captivity. Dissections of mature nymphs show the alimentary canals empty and in many cases even so collapsed that they are difficult to find at all. Likewise the nymphs kept for rearing refused all food for eight or ten days before transformation.

With growing nymphs it is different; here it is a task to supply them with enough food to prevent their eating one another. In a single day three or four of these nymphs will dispose of a score or more black-fly larvae and half as many small may-fly nymphs. Their greed is brought out even more strikingly by examining the food mounts of nymphs taken from the stream; whole specimens of midge larvae are found not uncommonly and sometimes a may-fly nymph with even the gills intact. The mass of food, however, consists of innumerable shapeless scraps of chitin with scattered fragments of abdomens, setae, antennae, legs; or claws, whole heads, mandibles, maxillae, and labia, making possible the recognition of may-fly and stone-fly nymphs, midge and simulium larvae and pupae.

The only evidence of any herbivorous tendency in this species is the presence of an immense number of diatoms in food amounts. Of course this is a question of direct or indirect eating. One would expect to find diatoms in a food mount made up of pieces of may-fly nymphs and chironomid larvae, and the natural supposition might be that the stone-fly got them second hand. Yet such a statement cannot be made without some hesitation, because the number of diatoms in the mounts seems to increase with a general decrease in the amount of food; and also because diatoms have been found to be the chief food of some of the smaller species of stone-flies.

*Transformation.* Just before the time of transformation when the nymphs cease eating they become sluggish. And as the time approaches they crawl further and further toward the surface of the water, and finally entirely out of it where they often remain for hours before emergence. The actual

casting of the skin has not been seen in this species. Although adults are rarely absolutely perfect specimens, the percent of individuals lost by inability to complete transformation is exceedingly small. Judging from the fact that no newly emerged insects have been found, it is thought that they must transform during the night, or more probably, in the early hours of the morning.

#### *Adults.*

*Characteristics.* The adult *Perla immarginata*, (Fig 5), is uniformly dull brown and much less conspicuous than the nymph. As soon as the insect loses its tracheal gills and gains four well developed wings, it is ready for aerial life. Unlike many adults with this equipment, some of the nymphal tendencies are carried over into this stage. Chief among these is the love for hiding. So great is their shyness that, even at the height of the emerging season, the adults are rarely found in the field. Repeated attempts at sweeping the foliage along the stream have met with little success. Careful searching of the rocky walls of the gorge has occasionally revealed an adult hidden away in a crack or crevice. Similar habits have been noticed in the adults kept in cages. They never rest on the twigs but crawl into hiding under the edge of the stones, or pans, or wherever they can wedge themselves into a tight place.

Although they avoid day-light, artificial lights attract them at night. They have been found crawling along poles and fences, or in the road under electric lights in the neighborhood of streams.

When disturbed the adults rarely seek escape by flight, but usually by running. Here again we see a nymphal trait, and a characteristic of the group. They are poor flyers and dependent upon their legs. Some stone-flies do not fly at all, although provided with fully developed wings.

*Food Habits.* A striking difference between the nymph and adult is found in the structure of the mouth and in the food habits. A character long assigned to stone-flies is rudimentary mouth parts of a biting type. This is true for *Perla immarginata*, but not for the entire order. In this species we have the reduction of the strong chitinous mandibles to mere fleshy lobes, (Fig. 1). The very appearance of such an apparatus indicates its uselessness, and examination of the

alimentary canal of adults taken in the field, has confirmed this. Water seems much more essential than food for these adults. If ever found out of hiding in their cages, they were almost sure to be on the stones in the pans with their mouths buried in water. Entirely deprived of water, the average length of life is shortened by several days.

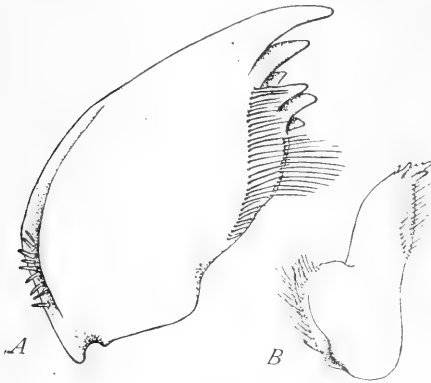

FIG. 1.

FIG. 1.

- a. Left mandible of the nymph, inner surface.  
b. Left mandible of the adult, same view and magnification.

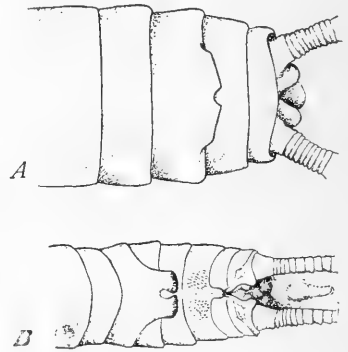

FIG. 2.

FIG. 2.

- a. Abdomen of the female, ventral view showing the modification of the eighth sternite.  
b. Abdomen of the male, dorsal view showing the genital armature with the penis extruded.

Both figures drawn to the same scale.

The voraciousness of the nymphs is necessary, since the adults abstain from food and since enough energy must be stored up to last through aerial life and the completion of the final function, reproduction.

*Mating.* Ordinarily mating begins soon after emergence. The readiness with which it takes place in captivity has been a great surprise on account of the natural timidity of stone-flies. Frequently pairs have been found in copula in the breeding cages and have been removed to adult quarters without arousing enough alarm to cause their separation. By careful manipulation copulating pairs can even be held in the palm of the hand. This has made a detailed study of mating possible.

Difference in size and external sexual characters make distinguishing the sexes easy. The smallest males measure not more than an inch to the tip of the wings, and the greatest measurement for a female is one and three-fourths inches. In the female the posterior border of the eighth sternite is thickened and slightly emarginate in the middle, (Fig. 2, A). The external sexual appendages of the male, although hidden by the wings, are much more prominent. The fifth tergite is prolonged in the form of a fork extending over the sixth and most of the seventh tergites. The tip of this meets a groove running through the mid dorsal line on the eighth, and surrounded on either side by papillose prominences. The ninth segment is shortened, and the tenth is slightly elongate ending in two strong recurved hooks, (Fig. 2, B).

Just how such an apparatus operated was not obvious at first or even second glance, in fact not until copulation was actually seen. The male rests upon the female grasping her wings and abdomen with the legs of one side, and supporting himself with the legs of the other side. Then bending the end of the abdomen around that of the female, and arching it forward, the male presses close against the female and pulls down the lamina, forcing the recurved hooks up into the vagina. After a few seconds, the male starts a slightly rhythmic motion by alternately pulling to and fro. As the motion becomes greater, the hooks are gradually withdrawn, and there is exposed between them a white, fleshy penis resting in the groove and supported toward the tip, by the fork on the fifth tergite. This rhythmic motion seems to be pump-like in action. With a quick jerk the recurved hooks are brought up against the fork, an act which causes the contraction of the penis and forces the seminal fluid up into the vagina. The expansion is slower, allowing the penis to become refilled. Undisturbed, copulation usually lasts about forty-five or fifty minutes. Except for microscopic horny papillae on the tip, the penis is entirely fleshy and composed of two telescopic segments. After copulation, it is gradually retracted into the body just below the anal opening, and entirely hidden inside.

*Egg-laying.* As is commonly known, stone-flies do not deposit their eggs directly, but carry them around for a time in a mass at the end of the abdomen. It is hard to see the reason for this. Apparently it is not to be found in the condition of

the egg itself, for there seems to be no difference between eggs just extruded and those carried for a couple of hours, half a day, or longer. There is a constant regularity in the length of time that elapses between copulation and extrusion of eggs, but not in the length of time eggs are carried. Individuals in the same cage eventually deposit their eggs in the same place, but one may carry them two hours, and another nearly a day under exactly the same conditions.

I am in doubt as to the normal method of depositing eggs. In the field, smaller species, carrying eggs, are often seen on the stones in streams as if they were about to crawl down to the water. And again they appear flying low along the stream and dipping to the surface as if ovipositing. No such observations have been made upon the larger species. The few adults of *Perla immarginata* which have been seen dropping their eggs in the pans seemed to do it more from accident than from intention. They were crawling around the stones and had floundered into the water. The instant they came in contact with the water the eggs dropped to the bottom of the pan. But many masses of eggs have been found in the pans too far from the edge, or from the stones, for them to have been dropped except from above, or by the individuals having actually crawled into, or on the water.

Concerning the place where the eggs are deposited there is no doubt. When the globular mass touches the water the eggs begin to separate. In the pans they finally settle down into a patch one layer deep, (Fig. 6). Of course this is not the case in the streams where the current scatters them broadcast. They are not tossed about long, however, for as soon as they come in contact with any object they become attached by the glutinous cap which surrounds the micropylar apparatus. These eggs are about half a millimeter long, dark brown in color and oval-shaped. Except for a single circular ridge the chorion is without ornamentation, (Fig. 7).

In following the movement of the different adults from day to day it was necessary to have some means of identifying them as individuals. As has been previously stated, an absolutely perfect adult is rare. Consequently it was a very simple matter to recognize individuals on such characters as a broken antenna or seta, a tarsus minus a segment or two, an imperfect wing, and so on. In this way during the season thirty-two

females and twelve males were kept under close observation. It was soon found that all the eggs were not deposited at one time. A few hours after the first mass was laid, mating occurred again, and within twenty-four hours a second lot had been deposited. Often there was a third mass, and in a few instances a fourth. These followed less rapidly.

As one would expect each successive mass was smaller than the one preceding. A thousand eggs is ample average for a first mass and four masses together would not total over sixteen hundred. It seems likely that a large number of eggs must reach the hatching stage. The chances of fertilization are good since copulation occurs more than once, also if one mass has fallen in an unfavorable place there is a possibility that the others have met with better luck. Yet the number of individuals which reach maturity is comparatively small. A great loss probably occurs during the early nymphal stage when the small white nymphs would be dainty morsels for many a larger creature.

Mating has the usual effect upon the length of life of the adults. When males and females are caged together the average female dies after six or seven days and the male after nine or ten. On the other hand if the sexes are kept apart they live twelve or thirteen days.

Only a small proportion of the eggs laid in captivity were kept for development. These were easily loosened from the pan with a pipette, removed to the glass tubes and put into running water. They have not yet hatched.

Ordinarily the one great difficulty which has stood out above all others, in attempting to get a complete life history of a stone-fly has been in the handling of the very young nymphs. Although a variety of methods have been tried, nymphs have not been kept alive for longer than ten days. Whether this is due to lack of proper environment, the right kind of food, or both, can not be said. The only possibility of tracing the life-cycle of a stone-fly, from egg to adult, seems to hinge upon a more complete knowledge of the early nymphal life.

#### PLATE XXIII.

- Fig. 3. Dorsal view of the nymph, natural size.
- Fig. 4. Ventral view of the nymph, natural size.
- Fig. 5. Adult female, natural size.
- Fig. 6. Mass of eggs, about 4 times natural size.
- Fig. 7. A single egg, greatly enlarged.

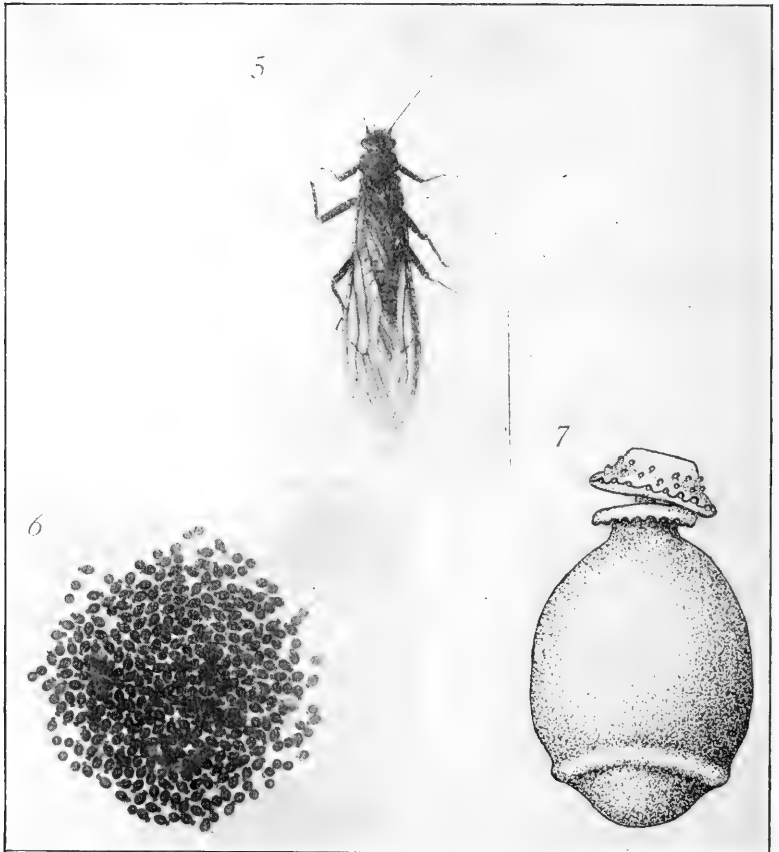



**THE LIFE-HISTORY OF A BEE-FLY (SPOGOSTYLUM  
ANALE SAY) PARASITE OF THE LARVA OF A TIGER  
BEETLE (CICINDELA SCUTELLARIS SAY VAR.  
LECONTEI HALD.).**

By VICTOR E. SHELFORD.

	PAGE
I. Introduction.....	213
II. Life History of the Parasite ( <i>Spogostylum</i> ).....	215
1. Adult Habit.....	215
2. Egg Laying.....	215
3. Egg.....	216
4. Larva.....	217
5. Pupa and Adult.....	219
III. Other Species.....	222
IV. Ecological and Geographic Distribution of Parasite and Host.....	222
V. Summary.....	225
VI. Acknowledgments and Bibliography.....	225

I. INTRODUCTION.

The life histories of the American Bombyliidæ are imperfectly known and this lack of knowledge is due largely to the difficulty of studying parasitic forms. The species in question is never abundant and consequently much time has been consumed in getting together the data for the account here presented. Near Chicago it occurs on dry sandy places where there is much vegetation and where the sand is slightly blackened with humus. The data presented were collected mainly in connection with work upon the host which involved collecting and rearing to maturity about a thousand host larvæ.

The larva of the parasite was first discovered in 1904 but none was successfully reared until 1906; the method of egg laying was not successfully observed until 1908 and 1909 while attempts to study the adult habits in 1910 and 1911 were only partially successful.

LIFE HISTORY OF THE HOST.

*Cicindela scutellaris* Say var. *Lecontei* Hald. is found in areas of dry sand to which considerable humus has been added by decaying vegetation (Wickham '02, Shelford '07, '11). Adults are present near Chicago from April to June and again in September. The fall individuals are those emerging from the pupal stage and are not sexually mature. These individuals pass the winter in the ground, become sexually mature after the warm days in April and deposit eggs in May and early June.

The young larvæ appear in late May and early June. The larvæ live in vertical burrows which end at the surface in a smooth circular opening (Fig. 2; also bh of Fig. 16, p. 221). They pass through three instars, the first two of which are about one month each in duration. The third and last stage is reached in the last part of July, in August and early September. These stages pass the winter in the burrows, appearing at the surface in May, and feeding until from June 20 to July 20. Each larva then digs a pupal (pch of Fig. 16, p. 221) burrow filling the main burrow at the same time. The larva remains quiet in this cavity for about three weeks when it pupates if it has not been parasitized, and emerges in August, making its way to the surface about three weeks later.

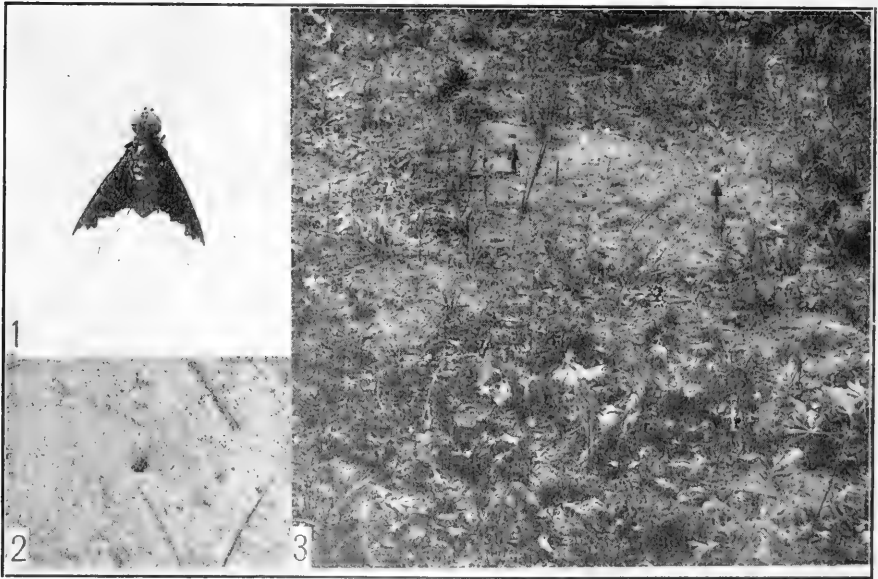

Fig. 1. The adult fly about twice natural size.

Fig. 2. A burrow of a larva of the second instar of *C. scutellaris Lecontei*, about natural size.

Fig. 3. General habitat of *C. scutellaris Lecontei* at a point where the fly was observed ovipositing, and the kind of situation in which the parasite is most abundant. The burrows of two larvæ of the host are in the last instar, and are visible above the small arrows.

II. LIFE HISTORY OF THE PARASITE (*Spogostylum*).1. *Adult Habits.*

The adult is a bright shiny velvet black fly with the basal two thirds of the wings black and the distal third transparent. (Fig. 1). It occurs in July and August, in open spots on sandy soil, especially in the kinds of situation shown in Fig. 3, where herbaceous vegetation and flowers are numerous. It is commonly associated with other bee flies such as *Anthrax impiger* Coq., *Anthrax fulvohirta* Weid., and *Anthrax molitor* Loew, which are much more abundant and often visit flowers in numbers, also *Exoprosopa*, which probably lays in the burrows of the *Bembecid* wasps. The habits of the male *Spogostylum* have not been observed. The female usually alights near the ground on the lowest plants or on sticks and leaves. In sunny weather she starts with remarkable swiftness when a shadow is passed over her but appears not to be stimulated by the presence of the observer under other conditions. In cloudy weather the writer has shaken an insect net within a few inches of one of the flies without causing her to move. The food habits have not been observed but a single individual lapped sugar and water from a piece of paper, while in captivity.

2. *Egg Laying.*

The female flies about two inches above the clear open sand in an irregular somewhat zig-zag fashion until apparently by chance its eyes pass above a hole in the sand, (Figs. 2 and 3). When this happens, the fly suddenly halts and moves backward and downward in a curved course. At the same time the abdomen is thrust forward so that it touches the surface of the sand at a point 5 to 10 mm. from the edge of the hole. The impact of the abdomen upon the sand is sufficient to perceptibly move small particles, some of which appear to fall in the burrow. The thrusts are usually repeated a number of times. After each movement, the fly returns to approximately the position at which the thrust began. The sight of the hole below the eyes acts as a trigger which sets off the thrusting reflex. The host larvæ frequently rest in the burrow some distance below the surface. On two occasions the fly stopped thrusting when the larva appeared near the surface. The size and shape of the hole appear not to be of prime importance.

Burrows of the second instar of *Cicindela* are most frequently visited. This is probably due to the fact that these holes are most abundant. The burrows of young spiders (*Geolycosa*) which have a web around the opening, are not rejected while holes of the first and third instars of *Cicindela* as well as partially covered holes produce the reaction at least once. General results of one observation are shown in table I.

TABLE I.  
A SEVEN MINUTE OBSERVATION OF THE EGG LAYING REACTION OF A FEMALE  
*Spogostylum*, July 16, 10:30 A. M.

Hole Producing Reflex	Stage	No. of Thrusts	Remarks
Burrow of— C. Lecontei	2 d.	7	Larva appeared.
Geolycosa	young	3-5	Web surrounding opening.
Large nondescript hole	...	...	Rejected after halt without thrust
Burrow of— C. Lecontei	2 d.	6	Stick half covering hole.
C. Lecontei	2 d.	2	Burrow less than one cm. deep due to closing near surface; probably during moult.
C. Lecontei	1st	2	
C. Lecontei	2 d.	5	Stick across hole.
C. Lecontei	3 d.	3-5	Partially covered.

A summary of the observation of egg laying is as follows: Egg laying thrusts were executed, by two individuals observed, before holes as follows: One first larval stage of the host, eighteen second larval stages including one partially covered with a stick, and a shallow one (filled below the surface); one third stage of *Cicindela*, one small spider hole. One large nondescript hole arrested the flight but did not produce the egg laying thrust.

### 3. Egg, (Fig. 4).

A female taken while laying was found to contain a very large number of eggs, which could be squeezed out by a gentle pressure upon the abdomen. The eggs are light brown ellipsoids .28 mm. by .12 mm. They are not adhesive.

## 4. Larva (Fig. 5).

Young larvæ are most commonly found singly on the ventral side of the thorax of host larvæ of the third instar, where they cling between the legs. No second instars have been found with parasites. While in the position between the legs they cannot be reached by the host and do not come readily into contact with the sides of its burrow. There are however frequent exceptions to this, for host larvæ not infrequently have more than one larva between the legs or single larvæ on other parts of the body. One host larva had in addition to the parasite on the ventral side of the throax, two others on the posterior third of the abdomen. Attempts to secure eggs or young larvæ from sand gathered from the edges of burrows about which eggs had been laid or to rear larva from eggs squeezed from a laying female, have failed. Neither have we

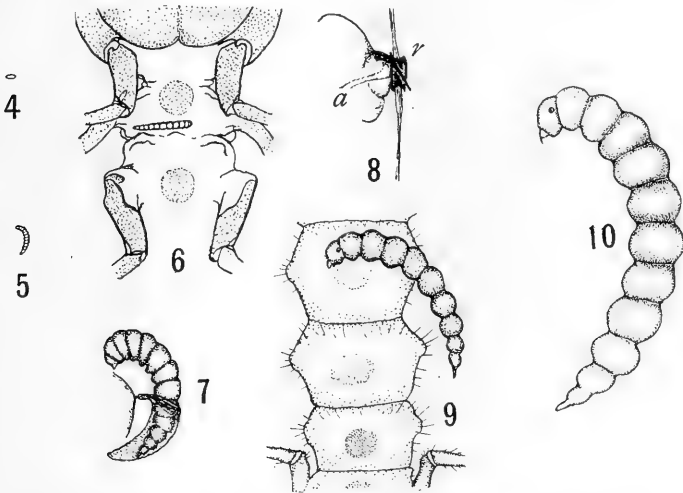

Figures 4-10. Early larval stages of *Spogostylum anale* Say.

- Fig. 4. The egg; enlarged about five diameters.  
 Fig. 5. A young larva of the second stage; about five times natural size, in a somewhat curved position.  
 Fig. 6. The same in position enlarged about nine times.  
 Fig. 7. At the time of moving to the abdomen; enlarged about five times. The larva has withdrawn its anterior half from the old integument.  
 Fig. 8. The larva in position in the thorax, showing the ring of thickened chitin(r) in the integument of the host and the long slender mandibles in position.  
 Fig. 9. The larva after one day on the abdomen of the host: about five times natural size.  
 Fig. 10. The larva at the end of the second day upon the abdomen.

discovered how the larva reaches the body of the host. The host larva with the three parasites was placed in a tube of sand one inch in diameter together with two other host larvæ, one bearing two parasites and the other uninfested. The double and triple infested hosts died leaving five parasitic larvæ in the tube with the one live host larva. *None* of the parasites *reached the host larva*. Host larvæ dug from the point where a female fly was seen, to deposit eggs on July 16 had parasites of the first and second instars on the ventral thorax when removed from their burrows Sept. 23d. About 7 percent of the host larvae are parasitized. While some catches of fifty host larvae were as high as 16 percent infested others were quite free from parasites. This is particularly true in the pine area (see p. 222), where only one out of several hundred host larvae were parasitized.

The structure of the larva was but little studied on account of lack of material. The head segment bears the usual mandibles, which are long and curved. They pierce the integument of the host obliquely; a ring of thickened chitin develops about them and the mouth is brought into contact with the center of the ring and thus with the tissues and fluids of the body (Fig. 8). The number of larval moults has not been fully determined and the following account is not necessarily accurate. The smallest larvæ found are from 0.5 to 0.6 mm. in length and are evidently in the first instar. These were taken in late summer and autumn and occasionally in spring. Most of these larvæ moult in the fall; all pass the winter attached to the body of the host, those of the first stage moulting in early May. When the larva moults, the integument splits in the region of the thorax. The anterior end of the body is withdrawn from the old skeletal parts, leaving the old mandibular skeleton imbedded in the host. The posterior part of the larva apparently remains in the old integument until the new integument of the head region is hardened when a new attachment to the host is affected. When again attached, the larva withdraws the abdomen from the exuvium (Figs. 5, 6 and 7).

The larvæ of the second instar, (length 1.2 to 1.6 mm.), probably moult again after the host has fed about a month (early June), but this is not certain because exact measurements could not be made of the small living larvæ while attached to the host and they could not be removed without killing them.

A third moult takes place about the time the host stops feeding (late June), but in the cases observed, before the pupal cell is constructed. This moult clearly takes place but the larva again could not be accurately measured.

In late June the host constructs the pupal cell (*pch* of *Fig. 16*, *p 221*) and becomes relatively inactive but does not normally pupate for a month. The parasite does not grow rapidly until the host has been in the pupal cell for about three weeks. By this time the old organs of the host have for the most part, broken down and the internal parts are in a semifluid condition. The parasitic larva now moults again and this time leaves its former position completely. In the four or five cases observed it moved to about the middle of the ventral side of the host, (*Fig. 9*). It will be noted that at the time of the previous moults of the parasite the host was active and if the larvæ had completely released its hold at any of these times the result would probably have been its own destruction. At the time of this fourth moult, on the other hand, the host is almost unable to move. Immediately upon securing the new source of food through the abdomen of the host the parasite begins to grow more rapidly and more than doubles its length in 48 hours. The length at the time of the fourth moult is about 4.5 mm.; after 24 hours the length is 6.5 mm. (*Fig. 9*), and during the next 24 hours the larva reaches a length of 1 cm. (*Fig. 10*), which is two-thirds the length of the abdomen of the host. At the end of 144 hours the parasitic larva is full grown (*Fig. 11*). The length is now 1.8 cm. and all of the later rapid growth has apparently taken place without further moulting. The full grown larva passes six or seven days in the pupal cavity of the host in a quiescent stage before the pupal moult occurs.

##### 5. *Pupa and Adult.*

The pupa is of the type common among the diptera. There are four curved hooks upon the anterior side of the head united at the base in the form of a fan (*Figs. 12 and 13*). Two smaller hooks on the ventral side of the head appear to correspond in position to the antennæ. There is a circle of long stiff bristles on each segment of the abdomen together with U shaped bristles on the dorsal side. The pupa upon emerging is unpigmented; the hooks on the head become dark in about five days; the head becomes light brown in nine days and dark

brown in thirteen days; pigment appears in the wings at the end of thirteen days in the center of the segments of the abdomen in two weeks. Pigmentation is apparently complete in about sixteen to eighteen days (July 13 to Aug. 3).

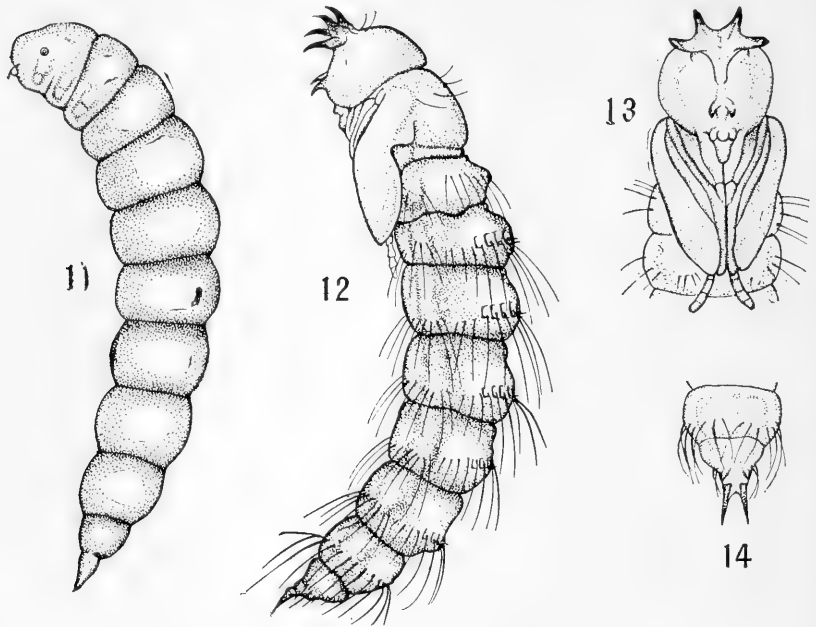

Figures 11-14. Late larvæ and pupal stages.

Fig. 11. Full grown larva showing the leg buds; enlarged five times.

Fig. 12. Side view of the pupa; enlarged five times.

Fig. 13. Front view of the anterior end of a fly pupa.

Fig. 14. Front view of the posterior end of the same.

Some time soon after the pigment is completely developed, the pupa begins to use the hooks for digging. In this process the numerous long stiff bristles arranged in a ring about the segments and projecting backward are of much importance for they tend to make simple movements either push the body forward or push loose sand backward. The large U-shaped bristles along the dorsal side may or may not function in this way also. The main digging operations are carried on by means of the hooks on the head. The two spines of the posterior end serve as anchoring organs. The body is curved dorsalward in the form of a bow with the dorsal side pressed against the upper side of the burrow. The U-shaped bristles prominent upon the dorsal side may function as anchors in this



operation. The two posterior spines are thrust into the floor of the burrow and the curvature is increased, which cause the head to move back as shown in Fig. 15. After a number of hoeing movements, the pupa usually wriggles backward carrying the sand with it by means of the bristles and again wriggles forward until the head is in contact with the end of the burrow. The hoeing movement is repeated or less frequently the body is rotated, the hooks serving as a boring organ.

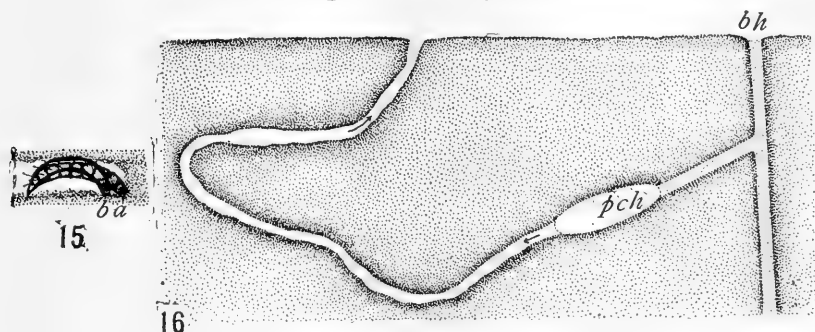

Figures 15-16. Emergence from the ground.

Fig. 15. Diagram showing the movement of the pupa in digging its way out of the ground. Natural size (a).

Fig. 16. Showing the burrow and pupal cell of the host with the path dug by the pupa of *Spogostylum*.

The boring movement was observed in the case of one individual, the host of which had been confined in a glass tube eight inches long and one and one-half inches in diameter. The burrow and pupal cell of the host were constructed in contact with the glass. Much of the life history of one parasite was thus observed. The digging of the parasite pupa began at night, and was not noted until the middle of the next forenoon (July 15), [began in pch of Fig. 16, p. 221]. During the last eight hours the larva progressed at the rate of 1 cm. per hour. It moved in contact with the glass and traveled more than once around the tube just inside the glass. The total distance through which the parasite dug was about 24 cm. Apparently immediately upon reaching the surface the fly emerged. It left the pupal integument sticking in the burrow. The emergence of the fly was not observed as the last centimeter of digging was accomplished in less than 20 minutes and the fly emerged between observations. The adult was found resting on a small blade of grass near the hole. This adult lived only about two days.

A pupa removed to a watch glass with the bottom covered with moist filter paper executed the digging movements for a day or more, but failed to emerge. One reared in a very small amount of sand and between two glass plates dug to the surface and then back into the sand again. It emerged in imperfect condition within the sand.

### III. OTHER SPECIES.

Work on the European species of the family Bombyliidæ is also far from extensive. Dufour gave an account of the larvæ, pupæ, and adult habit of *Bombylius major*. He found this species in March 1857 on the sloping banks of sand hills with southern exposure. He saw the fly light quickly at the openings of the burrows of Hymenoptera. In the locality, the burrowing hymenoptera were principally Andrenidæ and especially *Colletes hirta*. Dufour was never able however to find the egg of the fly. Williston '08, p. 213, summarizes the known hosts of the Bombyliidæ. In connection with the study of *Spogostylum anale* (July 30), *Anthrax impiger* was seen resting on the ground touching the abdomen to the surface of the sand. *Anthrax impiger* Coq. (July 16-30), lights on blossoms of horse mint, etc. or rests on other objects on the ground. Two, a pair, of *Exoprosopa fascipennis* Say were taken while flitting before a burrow of *Microbembex monodonta*.

### IV. ECOLOGICAL AND GEOGRAPHIC DISTRIBUTION.

#### 1. Ecological Distribution of Parasite and Host.

Near Chicago, the fly larvæ appear to be confined to *C. Lecontei*. One or two larvæ of *C. hirticollis* which do not occur with those of *C. Lecontei* were found to bear similar parasites. Adults of *Spogostylum* have never been seen near the *C. hirticollis* habitat. *C. purpurea limbalis* which lives on steep clay bluffs is parasitized by a larvæ somewhat different from that of *Spogostylum*.

In 1907 and 1912 I pointed out that the development of vegetation upon the sand areas at the head of Lake Michigan takes places in an orderly fashion. Cottonwoods are the pioneers and are accompanied by *Cicindela lepida*. Only one *Spogostylum anale* Say has been seen in these localities and this when a strong wind was blowing from a more favorable habitat. The cottonwoods are succeeded by pines and *Spogostylum* is rare among them. *Cicindela formosa generosa* occurs in the

mixed pine and cottonwood areas but none of these have been found with parasites. The large pit and goose-neck burrow probably prevent this species from serving as a host (Shelford, '08). Very few parasitized *Cicindela Lecontei* larvæ have been taken here though the host is only a little less abundant than in the oak area. It is on the margins of the depressions in the pine areas that the larvæ of *C. tranquebarica* Hbst. are numerous (Shelford '07) but none of those of this species were found parasitized, though the number of larvæ dug was great.

*Spogostylum anale* and its host species are most abundant in the early stages of the black oak forest where cacti occur (Fig. 3). The exact landscape aspect is significant only as an index of the physical conditions. The evaporation in these open oak forests is about one half that of the cottonwood area and less than that of the pine area. The available soil moisture is less (Shelford, '12).

## 2. Geographic Distribution.

American dipterologists have kindly supplied me with data on the distribution of *Spogostylum anale* as follows:

Prof. D. W. Coquillett: Sandy Hook, N. J.; Indiana; Carbondale, Ill.; Mississippi; British Columbia; Washington; Mesilla, N. M.; St. Louis, Mo.; Shreveport, La.; Georgia; Enterprise, Fla.; Cambridge, Mass.

Dr. J. S. Hine: Mission, British Columbia; Onaga, Kansas; Akron, Ohio; Cincinnati, Ohio.

Dr. C. T. Brues: Douglas Co., Kansas; Crete, Nebr.; Austin, Texas.

Dr. C. F. Adams: Jackson Co., Mo.; Lawrence, Kan.; Clark Co., Kan.; Fayetteville, Ark.

Prof. E. P. Felt: South Britian, Conn.; Albany, N. Y.

Prof. J. H. Comstock: Manlius, N. Y.

Dr. A. L. Meander: Galveston, Texas; Golden, Colo.

Map (Fig. 17) shows the distribution area of the host (A) generously represented by connecting the more remote localities along nearly direct lines where suitable habitats are known to occur. The distribution of the parasite is wider than that of the host species including all varieties extending into Mexico and along the Pacific coast. Accordingly the parasite must use another host. Several other species of the tiger beetles may no doubt serve this purpose.

Some of the flies reared in a hot green house lacked the white hairs along the abdomen, which characterize the species. Prof. Williston tells me that these hairs were absent from specimens taken in Mexico and doubtfully referred to this species by Osten Sacken.



Fig. 17. Showing the distribution area of the host species. (A of the legend.) The area blocked out is generous including all the probable territory. The crosses (B of the legend) represent state and country records. The round dots (C of the legend) represent some of the definite localities from which the fly has been recorded.

## V. SUMMARY.

1. The adult fly deposits eggs at the edge of circular openings in sand. In the areas inhabited by the flies (near Chicago) these openings are usually the larval burrows of *C. scutellaris Lecontei* Hald. p 215.

2. The sight of the burrow opening, beneath the eyes appears to call forth the egg laying reflex, p. 215.

3. The larvæ live as ectoparasites upon the tiger beetle larvæ for a little less than one year, growing slowly and moulting several times, p. 217.

4. When the host is ready to pupate, the larva moults, moves to the abdomen and grows to adult size in about six days, p. 219.

5. When the pupa is fully mature it digs out by means of hooks on its head and backward projecting bristles on the abdomen. The digging is sometimes downward for a time and lasts for more than 24 hours, p. 221.

6. The parasite is more widely distributed than its host, p. 223.

## VI. ACKNOWLEDGMENTS AND BIBLIOGRAPHY.

The writer is indebted to Dr. S. W. Williston and Mr. C. A. Hart for the identification of the Bombyliidæ, and to the gentlemen named above for the distribution records.

- Aldrich, J. M.** A Catalogue of North America Diptera. Smithsonian Misc. Coll. Vol. XLVI, (No. 1444). Cites work on life histories.
- Dufour, Leon.** '58. Histoire des Metamorphoses du Bombylius major. Ann. Soc. Ent. Ser. 3. Tome. 6. pp. 503-511, pl. 13-111. Fig. 1-9.
- Shelford, V. E.** '07. Preliminary Note on the Distribution of the Tiger Beetles and its Relation to Plant Succession. Biol. Bull. Vol. XIV, pp. 9-24.
- Shelford, V. E.** '08. Life histories and Larval Habits of the Tiger Beetles. Linn. Soc'y's Journal Zoology, Vol. 30, pp. 157-184.
- Shelford, V. E.** '12. Ecological Succession IV. Vegetation and the Control of Animal Communities. Biol. Bull. XXIII, pp. 59-99.
- Townsend, C. H. T.** '93. The Pupa of *Argyramœba œdipus* Fabr. (*Spogostylum*). Am. Nat. Vol. XXVII. No. 313, pp. 60-63. Jan., 1893.
- Wickham, H. T.** '02. Habits of North American Cicindelidæ. Proc. Davenport Ac. of Nat. Sci., Vol. 7, pp. 206-228.
- Williston, S. W.** '08. Manual of North American Diptera. New Haven.

## A NEW APPLICATION OF TAXONOMIC PRINCIPLES.

By CHARLES H. T. TOWNSEND, Lima, Peru.

Scarcely more than half a century has passed since the belief was generally entertained as indisputable that species and other taxonomic categories were fixed and unchangeable entities. The basic elements of current taxonomy date a century farther back.

Our taxonomic system was founded on the principle of permanency in organic morphology, without any idea of change and evolution. In its original concept and application it was therefore inelastic and not in accord with the facts. We have been constantly endeavoring, however, to apply this inelastic system to the elastic morphology of living matter. The result is a demonstration of incompatibility between the two.

Any taxonomic system must be arbitrary and fixed in certain of its fundamental aspects, but it must also accord with phylogenetic facts. A radically new system is not here proposed, but merely a modification of the current system to fit the phylogenetic facts that we find today. It is not held that living matter is morphologically changing with such rapidity that it needs a system which will change within a lifetime in order to keep up with the progress of evolution. But it is held that living forms exhibit distinct phylogenetic phases according to the age of the stocks of which they form a part, and that this fact must be taken into account in their taxonomic treatment.

No stock is today changing rapidly enough in nature for us to note the specific steps of change. But if we pass all stocks in phylogenetic review we are struck most forcibly with the successive but gradual change of conditions exhibited as we proceed from the oldest to the youngest stocks. In such review we get an instantaneous reflection of the bimorphologic changes which take place in time.

It has fallen to the lot of the writer to make a critical study of the morphology and phylogeny of the muscoid flies, which undoubtedly comprise some of the youngest stocks of insects, and to attempt to establish a taxonomic treatment of them which shall accord with their morphology and phylogeny and

thus prove satisfactory from all practical points of view. In this task difficulties have been encountered which can only be surmounted by conforming to lines of logical simplicity. Phylogenetic facts can not be changed. The logical alternative is to change our pseudophylogenetic plan of taxonomy to a phylogenetic one.

The history of muscoid taxonomy furnishes a vivid illustration of the necessity for such change. The chronologic alternation between splitting and lumping has been constant, but always gradually tending toward greater radicalism in the former. Brauer and Bergenstamm were the first students of the superfamily to recognize the difference in phylogenetic conditions existing here and to put the idea into words. Their system of taxonomy shows that they approached much nearer to the truths of phylogeny than had any former students of the group, but they failed in many cases to grasp the relationships because they had no uniformly true criterion thereto in the external adult anatomy. It has been left for students since their time to discover criteria in the reproductive system and early stages that furnish unmistakable clues to these relationships.

It was the good fortune of the writer to figure largely in the last named investigations, and therefore to obtain facts which constitute a definite basis for phylogenetic deductions. Once such deductions are authoritative—recognized as unmistakably founded on fact—we are able to proceed with confidence in the separation of forms of diverse origin, however similar may be their external morphology. This process brings us face to face with phylogenetic facts that could never before be confidently accepted, and with many which were never before suspected to exist. It compels us to draw lines where such were never before imagined, and it emphasizes with extreme force the shortcomings of current taxonomy if applied to young stocks.

The writer claims in this connection nothing more than a clear view and conscientious record of what has come within his range of vision. The privilege of applying a phylogenetic key to the taxonomy of some of the youngest and most obscurely differentiated groups of insects has been his, and it has furnished him an insight into the relationships of these groups and into the taxonomic needs of young stocks in general that was only

dimly comprehended before. The one who uses this key conscientiously and with fair judgment must get this insight. It only remains to bring the taxonomy into accord with the conditions. This is no simple matter, but it is capable of adjustment.

A careful comparative study of muscoid conditions by the writer, extending over the past five or six years and beginning before the reproductive and early-stage criteria became available has resulted in what may be called the typic-atypic application of taxonomic principles. The idea was dimly comprehended in 1907 from a study of the external adult anatomy alone and published in May, 1908 (*Tax. Musc. Flies*), while a clearer perception of it was gained and the foundation for its practical application laid during the next few months and the results published in September, 1908 (*Rec. Res. from Rear. and Dis. Tach.*). From that time to the present the typic-atypic idea in taxonomy has kept pace with the progress of the investigations into the reproductive and early-stage characters of the muscoid flies as compared with their external adult morphology. The working out of the scheme of application with the view of ultimately bringing it to a point of completeness has been laborious in the extreme, and many mistakes and new starts have been made. Theoretical phylogeny and a taxonomic application to match have been constantly checked up by practical and actual phylogeny, thus showing errors that have had to be corrected.

The writer has been still further fortunate in being able to spend some time during the past three years, 1910 to 1912, in several districts of the Andean montanya in Peru and Ecuador, perhaps the most favored biotic region on earth and thus the best adapted to illustrate the working out of phylogenetic principles in nature. Here he has been tremendously impressed with the extreme richness in transitional forms displayed by certain of the youngest muscoid stocks, which have furnished additional proofs of the soundness of the typic-atypic system of treatment. A paper on these forms is forthcoming (*New Gen. and Spp. Musc. Flies, chiefly Hystriciidæ from the And. Montanya*).

The typic-atypic system calls into use the new group-unit category, which includes the typic genus and such atypic genera as approach more closely to it than to any other typic



genus. It has gradually become evident that this category is a natural prime division of the subtribe, demanded in young stocks where transitional forms are numerous present but not as a rule called for in older stocks where such transitionals are infrequent.

It may be pointed out by way of illustration that we know many insect stocks whose component forms are well differentiated from each other; we know other insect stocks whose forms are less markedly differentiated among themselves, and we know still further stocks which comprise masses of closely similar forms. The first are old stocks, the second are middle-aged stocks practically in their prime; the last are young stocks, still undergoing evolution and characterized by the presence of many transitional forms. The same system of taxonomy is not applicable to all these classes of stocks. The three classes mentioned are of course not clearly delimited, for certain stocks are bound to be intermediate between them. But each stock can always be treated on its own merits. For the first class in general, the current system of taxonomy answers fairly well—that is to say, the tribes are usually quite easily divided directly into genera. In the second class, comprising in general the stocks of middle age, we need the subtribal category between the tribe and the genus. In the youngest stocks we need to employ still another category, as an elementary grouping of genera, between the subtribe and the genus. This is what has been termed the group-unit, for it is both theoretically and practically the unit of taxonomic groups.

So far as it has been possible to work out the status of the group-unit to date, its value appears to correspond to a fractional part of the contracted subtribal value and the whole or a part of the transitional subtribal value, as these values are exhibited in young superfamilies and stocks undergoing evolution. The group-unit therefore corresponds to the well marked genus in the old stocks, plus its intergeneric space which is conceived to be a fixed quantity covering certain transitionals that have dropped out. The well marked genus itself corresponds to the typic genus of the group-unit, while the latter has associated with it various transitional or atypic genera which are not represented in the old stocks but must here be fitted into the taxonomic system. These transitionals or atypic genera are not subgenera of the typic genus. They are subordinated to

the latter only in consensus of characters and not in value. They correspond to the intergeneric space that belongs with the well marked genus in the old stocks, but which forms no integral part of it. The writer has considered well the possibility of interpreting the group-unit, as here constituted, to be the natural genus, and thus of doing away with the necessity for the name group-unit by employing the subgeneric category instead of the generic for the group-unit's prime divisions. This plan has proved not to be practicable. Subgeneric divisions may often be recognized within the typic genus, and sometimes in the atypic genera, so neither can be considered subgenera. In the sum of their characters the typic and atypic genera are too distinct from each other to be considered as mere ill-defined groups of species under a genus embracing all the forms in the group-unit. Genera are prominently distinguishable groups of species, and the atypic as well as the typic genera fit the definition. Furthermore, in the young stocks there are inter-subtribal groups of transitionals which come between the subtribes proper or typic subtribes, and which may be termed transitional or atypic subtribal groups. The group-unit is capable of representing in their true relationships and thus accomodating in the taxonomic system these transitional subtribal forms, which do not occur in the old stocks and can not be fitted into the system of taxonomy commonly applied thereto.

Attention must be drawn to the fact that stocks become fixed, and thus easily amenable to delimitation on the old plan, only when their evolution is completed. The lives of stocks and groups of stocks may well be likened to the lives of individuals. They differ in extending over far greater periods of time, which is only a relative difference. Like individuals, they spring from small and embryonic beginnings, are launched upon the outer world, gradually grow, unfold, develop, pass through various stages of change and specialization, in time reach their zenith and cease evolution, finally wane, become senile and eventually extinct. Waning and senile stocks and all those that have ceased evolution, that is to say fully matured stocks, are easily defined because few or no transitionals are present to hinder definition. But stocks that have not yet reached their zenith, that is to say adolescent stocks, are filled

with transitionals and hence their component categories are difficult of delimitation.

These facts and the consequent necessity for a fractional subtribal category must be apparent to anyone who studies these flies assiduously. In many cases the natural tribes and subtribes can not be defined on the external characters of the adult, nor can they be defined in other than a very complex and thus highly unsatisfactory manner on all characters, due to the presence of the transitionals, and we are thus forced to employ more restricted group categories in order to make a taxonomic system fit them. The conditions which we face here are those that obtain at any given time during the active evolution of new and young stocks. If we had all the individuals that have been produced during the evolution of any subtribe of insects, arranged before us in the order of their descent, we would be totally unable to classify them into either group-units, genera, subgenera or species, simply because no lines of division would be indicated for such separations. They would be found to form a mass of transitionals in a gradual and spreading transition from first to last; through their roots all would be found to connect by gradual transitions with each other. But at any given point in their development by excluding their predecessors, the remnant would be amenable to separation into categories after the group unit plan. These conditions actually obtain in certain young stocks today, and it is only due to the fragmentary nature of the material which we are able to secure out of their totals of countless individuals produced that we are able to attempt a classification of the residue. We do not have to fit their predecessors into the taxonomic system, since they are all lost to us except recent material which agrees with the present. Therefore we are able to draw lines of separation, but the transitionals present demand that the lines be drawn closely. Here lies the necessity for the group-unit category. Its province is to represent the transitional subtribal forms in their true relationships to the typical divisions of the subtribe proper, in young and new stocks now undergoing evolution.

The term group-unit was chosen because the value of the category to which it is applied is bound to be the unit of group values. Species and genera are both taxonomic units, since both enter into the concept and construction of the binomial.

The elemental combinations of genera must thus constitute the units of group formations and values. It is proposed that the name of the group-unit be formed by adding *ia* to the root of the name of its typic genus. This does not conflict with any of the group endings established by the International Code and by general usage.

The group-unit permits us to arrange with phylogenetic fidelity the components of stocks whose transitionals are largely present, fitting all into a natural taxonomic system. There can be not the slightest doubt that this category is an absolute necessity to the clear and concise taxonomic handling of the forms that comprise the youngest stocks. The further details of the new application of taxonomic principles here outlined largely remain to be worked out. This must be done by applying the principles to the young stocks themselves as they exist today.

## A STUDY IN ANTENNAL VARIATION.\*

By EDITH M. PATCH.

PLATES XXIV-XXVII.

During the summer and fall of 1912 annulation counts of 1243 antennae of *Schizoneura* developing on *Ulmus* (leaf and bark), and *Pyrus* and *Crataegus* (bark) were made by Mr. William C. Woods and the writer of this paper.

A detailed record of the annular sensoria present on each of joints III, IV, and V of every antenna counted, giving a tabulation of 3729 counts in all, is preserved on file at the Maine Agricultural Experiment Station and a copy of this record will be lent upon request to any one making a particular study of the species concerned. The counts in tabular form are too bulky to be conveniently printed as they stand; and as nearly 100 curves would be necessary to cover the various collections adequately that method of presentation was also rejected for the time though part of the data may be reduced to this form later.

The drawings of the 90 antennae selected show, however, the most significant ranges of variation and give in themselves a summary sufficient for most purposes. The antennae are all drawn to the same scale with particular reference to the number of annulations present on each of the joints III to V and where of interest also of joint VI; and the length of each joint. No especial attention has been paid to other antennal details and the drawings are not to be considered a study of the terminal joint except in the two respects indicated. In some instances the drawings were made from mounts in which the antenna was curved on the slide and an arbitrary correction of this for the purpose of getting approximately straight drawings for plates, gives the peculiar irregularity in contour apparent.

Frequent examples of freak antenna in which two joints were apparently merged were met and some of these are represented by Figs. 32-36 and Fig. 82.

Appreciative thanks are due to several widely scattered entomologists for their kindness in sending material from different localities, who are, in part, acknowledged in the collection data which follow.

---

\*Papers from the Maine Agricultural Experiment Station; Entomology No. 62.

*History of Collections Tabulated.*

39-04. (Fig. 74). Elm rosette. Orono, Me. June 15, 1904.

6-05. (Fig. 90). Mixed collection from elm leaf roll and rosette. Orono. June 16, 1905.

95-06. (Figs. 19-21). Elm bark. Orono, Aug. 4, 1906.

114-06. (Fig. 29). *Crataegus* bark. Maine. Sept. 17, 1906.

115-06. (Figs. 30-31). Apple bark. Maine. Sept. 17, 1906.

7-08. (Fig. 22). Elm bark. Orono. June 16, 1908.

50-09. (Figs. 14-18). Elm leaf collection. Brewer, Me. July 1, 1909.

63-11. (Figs. 23-26). *Pyrus* sp. bark. (cultivated variety of mountain ash). Orono. Aug. 28, 1911.

64-11. *Pyrus sitchensis* (Roem) Piper, bark. Orono. Aug. 29, 1911.

6-12. (Fig. 13). Elm leaf roll. Alabama. Received May 6, 1912. Progeny of this collection lived for a fortnight on apple seedlings.

9-12. (Fig. 11). Elm leaf roll. Columbia, Mo. Received May 12, 1912, from Dr. L. Haseman. The winged progenitors of 9-12. Sub. 1. (Fig. 27) which were reared in the laboratory on apple seedlings. A fuller account of this collection is given in Bulletin 203 of the Maine Agricultural Experiment Station.

9-12. Sub. 1. (Fig. 27). Apple seedling. Laboratory bred. Sept. 20, 1913. The progeny of 9-12 which see for discussion.

11-12. (Fig. 12). Elm leaf roll. Knoxville, Tenn. Received May 20, from Dr. Gordon Bentley. Progeny of this collection were reared on apple seedlings from May 20 to June 26.

12-12. (Fig. 10). Elm leaf roll. Marion, S. C. Received May 28, 1912, from Mr. W. A. Thomas.

21-12. (Fig. 89). Mixed collection from elm leaf roll and rosette. St. Louis, Mo. Received June 3, 1912, from Mr. J. T. Monell.

29-12. Elm rosette. Orono. June 6, 1912.

30-12. (Figs. 83-88). Elm leaf roll. Marion, S. C. Received June 8, 1912, from Mr. W. A. Thomas.

35-12. (Figs 8 and 9). Elm leaf roll. St. Louis, Mo. Received from Mr. J. T. Monell, June 14, 1912.

43-12. (Fig. 2). Elm leaf roll. Orono. June 20. For discussion see 113-12.

45-12. (Fig 68). Elm rosette. Calais, Me. June 21, 1912.

49-12. (Figs. 76-82). Elm rosette. Standish, Me. June 24, 1912. The rosette was old and considerably dried and the migrants were smaller than those from fresher and juicier rosettes.

53-12. (Figs. 3 and 4). Elm leaf roll. Orono. June 26, 1912.

57-12. (Fig. 69). Elm rosette. Caribou, Me. June 26, 1912.

58-12. (Fig. 75). Elm rosette. Berlin, N. H. June 28, 1912.

60-12. (Figs. 32-67). Migrants developed in elm leaf roll and rosette. Collected June 28-July 12, 1912, from the ventral surface of leaves of *Pyrus americana* (Mountain Ash), to which they had migrated. A fuller account of this collection is given in *Journal of Economic Entomology*, Vol. 5, p. 397.

61-12. (Figs. 70-73). Elm rosette. Oakland, Me. June 29, 1912.

65-12. Elm rosette. Orono. June 21, 1912.

68-12. (Fig. 1). Elm leaf roll. Houlton, Me. June, 1912.

111-12. (Fig. 5). Elm leaf roll. Orono. July 20, 1912.

113-12. (Figs. 6 and 7). Elm leaf roll. Orono. July 23, 1912. Purposely collected late for comparison with 43-12 (Fig. 2) which developed June 30 in the same rolls. The difference in the actual size of the antennae and in the number of annulations of the big, thrifty early ones from the juicy leaf and the last individuals to develop in the drying roll would seem suggestive of the physiological effect of the habitat on the size of the individual and the character of the antennae.

165-12. *Pyrus sitchensis* Piper, bark. Orono. Sept. 24, 1912.

175-12. Apple bark. Orono, Me. Sept. 28, 1912.

176-12. (Fig. 28). *Crataegus (monogyna) Oxyocantha*. St. Louis, Mo., September 27, 1911. Mr. J. T. Monell.

NOTE. By elm leaf "roll" is indicated a deformation of a single leaf. By "rosette" is indicated a terminal cluster. (Figs. 442 and 462, Bulletin 203, Me. Agr. Expt. Sta.).

*List of Figures With Cross Reference to Collections.*

Fig 1, 68-12; Fig 2, 43-12; Figs. 3-4, 53-12; Fig. 5, 111-12; Figs. 6-7, 113-12; Figs. 8-9, 35-12; Fig. 10, 12-12; Fig. 11, 9-12; Fig. 12, 11-12; Fig. 13, 6-12; Figs. 14-18, 50-09; Figs. 19-21, 95-06; Fig. 22, 7-08; Figs. 23-26, 63-11; Fig. 27, 9-12 Sub 1; Fig. 28, 176-12; Fig. 29, 114-06; Figs. 30-31, 115-06; Figs. 32-67, 60-12; Fig. 68, 45-12; Fig. 69, 57-12; Figs. 70-73, 61-12; Fig. 74, 39-04; Fig. 75, 58-12; Figs. 76-82, 49-12; Figs. 83-88, 30-12; Fig. 89, 21-12; Fig. 90, 6-05.

Figs 17 and 18 are right and left antennæ of same individual.

Figs. 37 and 38 are right and left antennæ of same individual.

Figs 64 and 65 are right and left antennæ of same individual.



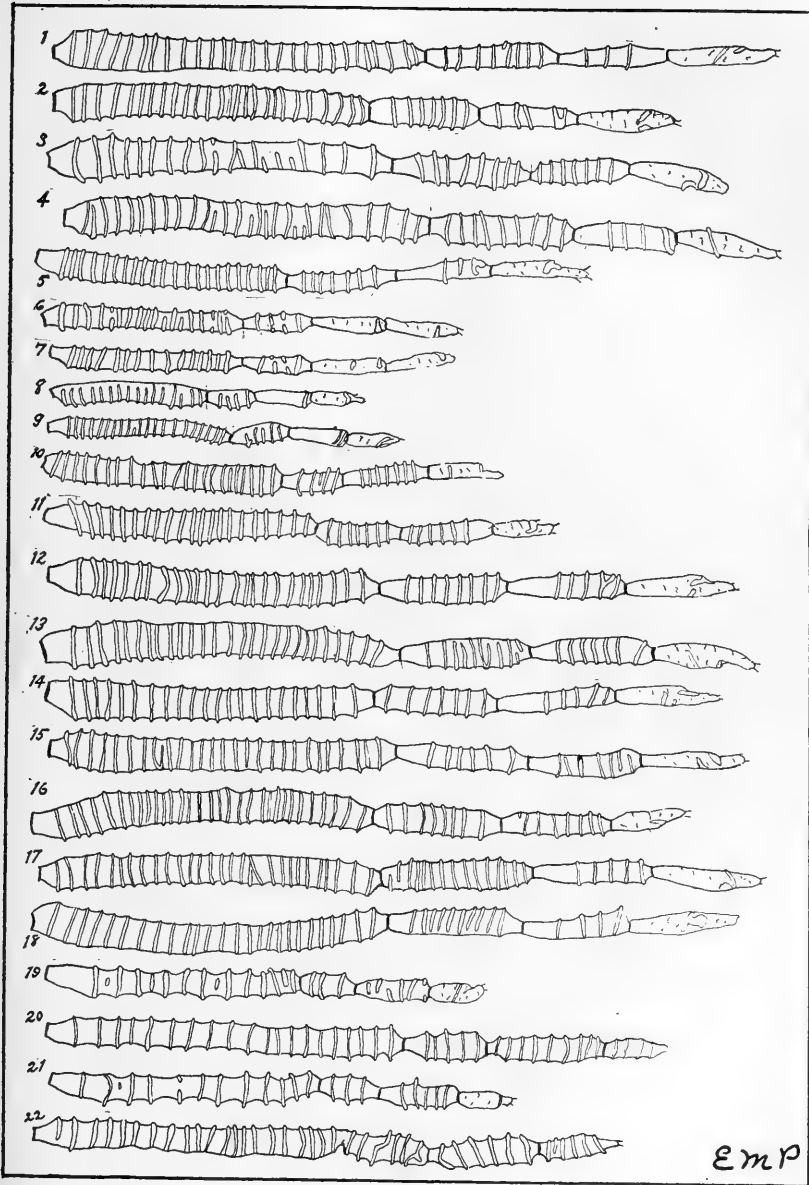

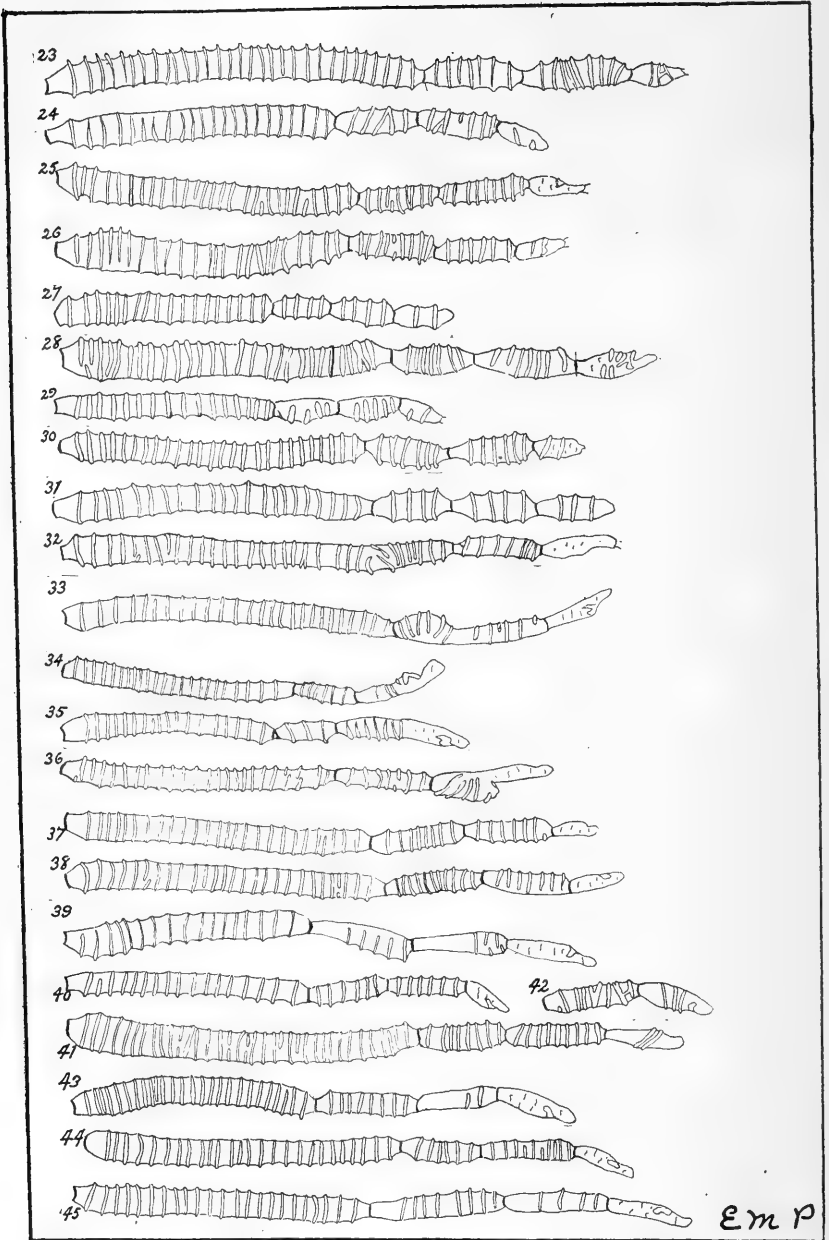

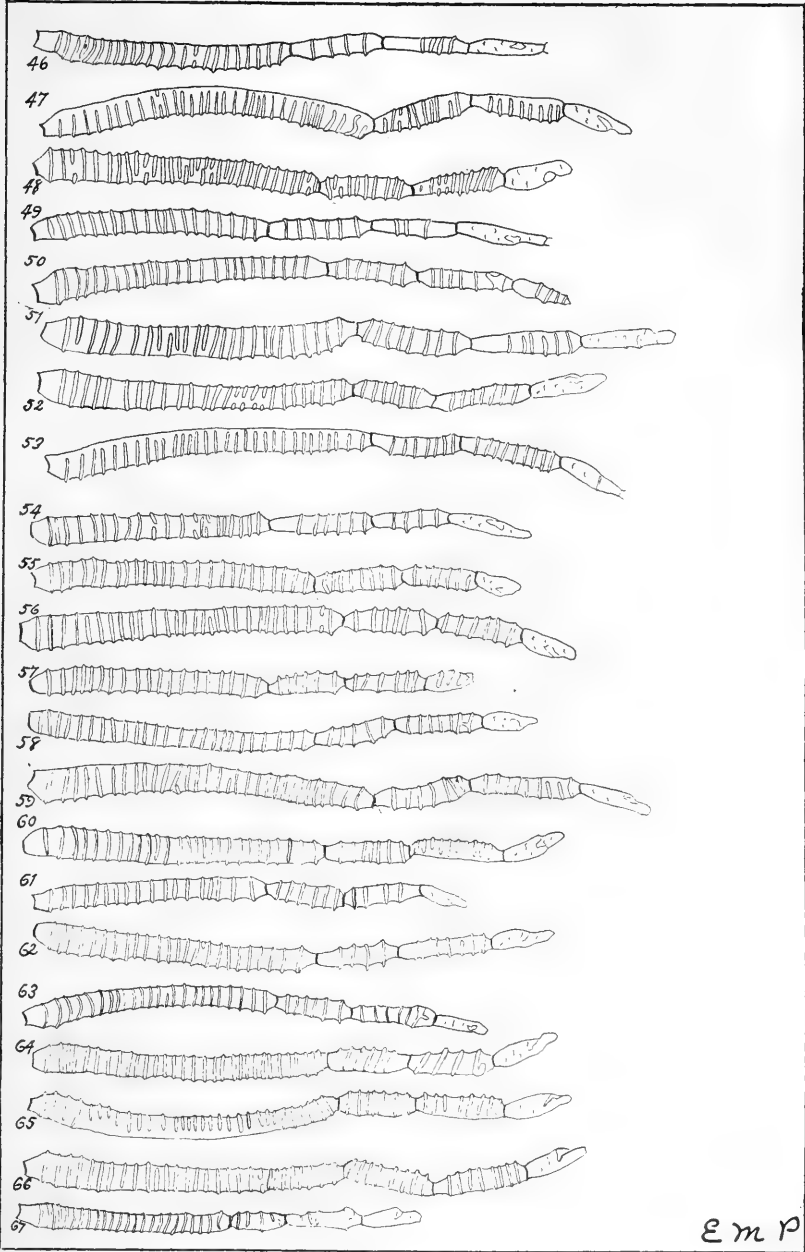

Edith M. Patch.

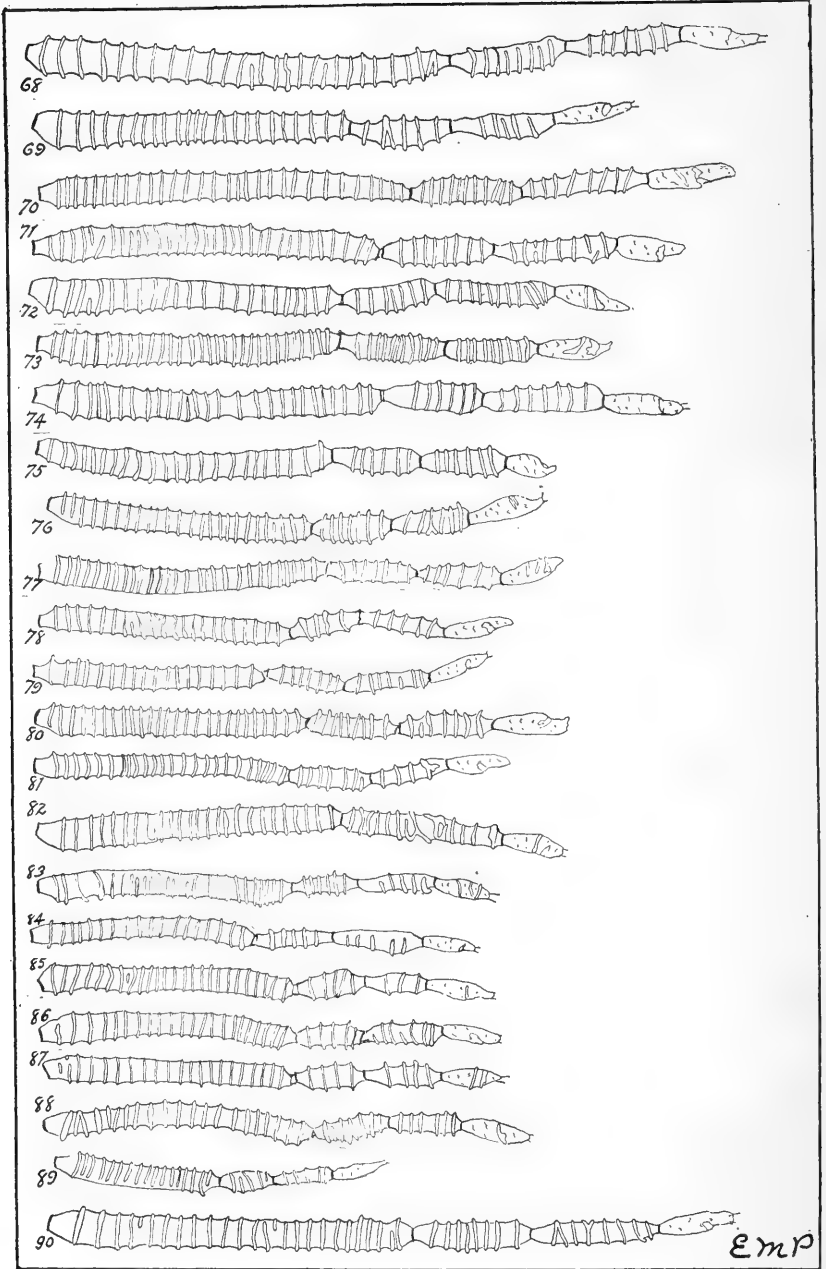

Edith M. Patch.

A STUDY IN VARIATION IN THE NORTH AMERICAN  
GREENBOTTLE FLIES OF THE GENUS LUCILIA,  
WITH SYSTEMATIC NOTES ON THE  
SPECIES INVOLVED.

By JOHN D. TOTHILL,  
Division of Entomology, Ottawa, Canada.

Some few years ago the writer had occasion to make a study in variation of the Canadian species of the genus *Lucilia*. Series of adults were bred, more particularly in the case of *L. sericata* Meig., and from the material thus secured the limits and possibilities of variation in certain directions were determined. The fact was brought out that none of the characters made use of by Mr. C. H. T. Townsend in his "Taxonomy of Muscoidean Flies" for the erection of the ten supposedly new species of the genus contained in that publication are of specific value.

In 1911 an opportunity was afforded of examining the types and cotypes of the above ten species at the U. S. National Museum, in Washington, D. C. The conclusion which had been previously arrived at namely, that the supposed species were only variations of the original four species as recognized by Hough was abundantly justified.

Examinations of the ♂ genitalia were made and these again showed that the conclusion was justified.

It is hoped shortly to publish the results of the study of the ♂ genitalia.

The present paper consists of the results of the study in variation, and of the examination of the U. S. N. M. *Lucilia* material.

A STUDY IN VARIATION IN THE GENUS LUCILIA.

That variation in external morphological characters is a factor to be reckoned with in systematic entomology is today disputed by no working entomologist. At the same time there are comparatively an infinitely small number of the vast array of insects described to date which have had their limits of variation approximated.

That such approximation is possible or practical in all cases cannot be entertained; that it is desirable is beyond question. The single historic example of the tachinid fly *Exorista (Phryxe)*

*vulgaris* Fall. with its five and one-half pages of synonymy in the "Katalog der Paläarktischen Diptera" is sufficient in itself to establish the desirability of studies in variation.

The present study is concerned with three species of the genus *Lucilia* i. e. *sericata* Meig. *sylvarum* Hough and *caesar* Linn. The method adopted was to breed from isolated egg masses series of adults, examine and record certain selected characters for each fly from each egg mass, tabulate these characters, make synopses of these tables, and finally to draw up from these synopses résumés or extended definitions for each species.

Owing to lack of space only these final résumés appear in this paper. It was the intention of the writer at the outset to keep exact records of at least one hundred examples of each species encountered. This intention was however only realized in the case of *L. sericata* in which case several hundred adults were reared. The number of specimens of each species reared and examined is as follows:

- L. sericata*, Meig., 158 consisting of 57 ♀♀ and 101 ♂♂.
- L. sylvarum*, Hough, 27, consisting of 25 ♀♀ and 2 ♂♂.
- L. caesar*, Linn., 3, consisting of 1 ♀ and 2 ♂♂.

In addition to these bred specimens ten collected specimens of *L. sylvarum* and thirty-one *L. caesar* were also examined, the results being included in the following résumés. This makes the total assemblage of flies for each species: *L. sericata*, 158; *L. sylvarum*, 37; *L. caesar*, 34.

The characters selected for examination were as follows:

- Dorsocentral bristles.
- Postracostichal bristles.
- Humeral bristles.
- Sternopleural bristles.
- Ocellar bristles.
- Width of front.
- Colour of palpi.
- Colour of first abdominal segment.
- Marginal bristles of second abdominal segment.
- Colour of tegulae.
- Width of apex of first posterior cell compared with the length of the anterior cross-vein.
- Presence or absence of appendage at bend of vein four.

These particular characters were chosen for two reasons (a) to find if possible new taxonomic characters for the separation of the species; (b) on account of the fact that they include all the new characters employed by Mr. C. H. T. Townsend\* in the erection of ten supposedly distinct species.

\* Taxonomy of Muscoidean Flies. Smithsonian Misc. Col., Vol. 41, No. 1803.

RESUME OF *L. SERICATA*.

In all cases there were three strong pairs of dorsocentral bristles, no rudimentary fourth pair.

In 98.1% of cases there were three pairs of postacrostichal bristles. One of the variations was an extra spasmodically placed bristle of the mesonotum (postsutural). The other variation was that of two postacrostichals only on the left side; this may indicate a past connection between the forms with typically three pairs and those with typically two pairs (*L. caesar*).

As regards humeral bristles 88.7% of the flies examined were supplied with four strong ones on each side. The variations ranged between a form with two on one side and three on the other and the typic form with four on each side. The anterior bristle was always the one to be lost.

The interior bristle seems to have a taxonomic affinity toward the anterior bristle, as in the case of the latter aborting it was usually found that the interior bristle was weak (in one case it was lost completely on one side).

There were in 96.9% of cases 3 sternopleural bristles on each side. This is a generic character and yet there was variation, not in the species as a whole, but in individuals. These variations were in an increase and decrease of these bristles in both number and strength. In all cases the posterior bristles were constant and the anterior alone became modified.

The ocellar bristles varied according to sex.

82.5% of the female flies had two well-defined pairs. In the great majority of these cases the anterior pair was longer and stronger than the posterior pair, but at the same time the latter pair was sufficiently strong to warrant the application of the term 'bristles'. As to position the anterior pair had their insertion within the ocellar triangle and the posterior pair had theirs outside of the triangle and immediately posterior to it. As to the exceptions to this normal condition of two pairs there were a few cases in which the post. pair were weak; one case in which the two pairs were both exceptionally strong; several instances in which there was an extra *bristle* developed on one side within the ocellar triangle and posterior to the normal anterior pair; and finally a few instances in which there was an extra *pair* of bristles developed within the ocellar triangle and post. to the ant. pair.

Of the males 90% had only one pair of ocellar bristles. These were proclinate and had their insertion within the triangle. There was a tendency toward the production of two pairs; in some cases this second pair was hardly stronger than the surrounding hairs; in 7% of cases they had developed into a weak posterior pair; and finally in a solitary instance two distinct pairs were developed.

The width of front affords a secondary sexual character. This character was very constant, there being practically no variation in all the material examined.

In the females the width was one-seventh to one-eighth head width. Hough in his description of this species gives one-sixth to one-eighth head width; this will hold good if that portion near the ocellar triangle is taken into consideration, as at this extremity there is an expansion. In the present study, however, the term width of front is restricted to that portion of the front immediately above the base of the antennae, i. e. the narrowest portion.

In the case of females the width of front was from one-tenth to four-tenths head width.

It may be stated here that measurements of all these flies was not attempted. A small series however of each sex were measured in this particular and with these as a guide the other specimens were visually compared. This may sound somewhat casual, but in reality the method is reasonably accurate as the observer very quickly acquires a due sense of proportion.

The next character lies in the color of the palpi. This character was sometimes very difficult to determine because the palpi were often retracted into the oral cavity. The wall of this cavity varied from an amber yellow color to almost black and the palpi, being semi-transparent, appeared in many cases to be of this dark color and only by removing them could the fallacy be made patent. Again these palpi were covered with fine white hairs and thus in certain planes of vision they appeared white.

The prevailing color of these palpi was amber yellow. This was however by no means constant, there being but 64.4% of the flies with the palpi of this color. The color varied from pale yellow through dark amber yellow to almost black; again in several cases there was an infuscation or dark area at the distal region; and also a black area was occasionally present



at the base. Thus for this species at least the color of the palpi is not constant and the infuscation at the tip has no specific value.

In the color of the first segment of the abdomen was found an excellent secondary sexual character. In all cases it is the dorsal area of the segment that is referred to and not the ventral.

In all males examined the first segment was, at least superiorly, black. In the females this segment varied from the color of the remaining segments (i. e. abdomen unicolorus) to a shade darker; there were few examples of this latter condition.

On the second abdominal segment there was superiorly a row in both males and females, of fairly strong marginal macrochaetae. These macrochaetae were stronger centrally, then became weak and finally became strong again at the sides. These bristles varied slightly, but not to any marked degree; in a few cases they were strong and in a few cases weak; in two instances (1 ♂ and 1 ♀) the two median bristles stood out more prominently thus approaching the condition in *L. sylvarum*.

The tegulae varied from white to brown. This variation was evident in all the series of flies of all species and in one lot of *L. sylvarum* bred from a single egg cluster all intermediate stages were found between the pure white and the brown conditions.

Before passing to the next character it may be well to observe that all flies killed and pinned soon after the time of issuance have pure, or almost pure, white tegulae; and that only in flies that have either been collected, or bred through and left in a cage for ten days or more, have the brown-tinged tegulae been observed. This seems to indicate that the tegulae darken as the fly grows older.

It was found that the width of the apex of the posterior cell in comparison with the length of the anterior cross-vein was slightly or distinctly shorter; the only exception to this was in the case of two flies in which the lengths were equal. This character has not previously been made use of. It is apparently very constant and serves as a separating character for this species from *L. sylvarum*.

The character is best seen when the wing is viewed from below. In vein 4 there was in no case any appendage—even rudimentary—at the angle.

RESUME OF *L. SYLVARUM*.

There were in all cases 3 strong pairs of dorsocentral bristles, but in 33% of the flies resulting from one egg cluster there was a trace of a fourth anterior pair; sometimes this trace exhibited itself as a slightly exaggerated hair on one side only and sometimes it resolved itself into a distinct but weak pair of anterior dorsocentral bristles. There were three pairs of strong postacrostichal bristles in all cases.

As regards humeral bristles there were in most cases four on each side. The majority of variations ran to an abortion of either one bristle on one side only, or of a bristle on both sides. This bristle was always the anterior bristle and, as in *L. sericata*, the loss of it carried with it a weakening of the anterior one. There was in one case a variation in the other direction, namely, the development of an extra bristle, quite strong, on one side only.

Sternopleural bristles were represented by three typical pairs, but, as in *L. sericata*, there was variation, notwithstanding the fact that the character has an undoubted generic value. This variation appeared in 4 specimens and ran in each case to an additional anterior pair, represented either by a bristle on one side only or by a bristle on each side; these bristles were sometimes weak and sometimes strong. In all cases as in *L. sericata*, only the anterior bristles were subject to modification.

Coming to ocellar bristles it was found that, as in *L. sericata*, these afforded secondary sexual characters. The four males had only one strong pair of ocellar bristles. These were proclinate and inserted within the ocellar triangle.

The females had one strong pair inserted within the ocellar triangle and one very weak pair inserted outside the triangle and immediately posterior to it. This weak pair was made up of somewhat exaggerated hairs but the term bristle is perhaps applicable because they stood out from the surrounding hairs (of which there were several pairs). There were in the specimens of this species as in the specimens of *L. caesar* a few hairs within the ocellar triangle. There was variation from the typical condition of one strong pair and one weak in two directions, namely, reduction of the posterior pair and the addition of another posterior pair of these weak bristles or strong hairs.

The width of front affords a secondary sexual character. In the males the front was from one-tenth to one-twelfth head width. Hough gives the width as "very narrow" and "one-eighth to one-tenth head width." A better way is perhaps to say that the width of front in ♂ *L. sylvarum* comes intermediate between that of *L. caesar*, which is linear, and that of *L. sericata* which is from one-seventh to one-eighth head width. Once having examined specimens as to this character in males of all three species it becomes a comparatively easy task to subsequently reduce any male *Lucilia*, on this character alone to its species.

The front of the females was found to be somewhat narrower than in *L. sericata* and about the same as in *L. caesar*. In actual width it was found to be about 3-10 (measurements were made in a number of specimens) of the head width; this is slightly less than 1-3 head width. This character serves very nicely for separating females of this species and of *L. caesar* from females of *L. sericata* which have a front measuring 4-10 head width, or slightly greater than 1-3 head width.

The color of the palpi appears to be far more constant in this species than in *L. sericata*. This color was dark brown or almost black in all but two cases and in these it was black. The color of the dorsum of the first abdominal segment was *not* in this case found to afford a secondary sexual character as in *L. sericata*. In the females the first abdominal segment was either blackish or black, and in the males it was black.

A comparative study of the bristles of the second abdominal segment produced some curious results. In the case of *L. sylvarum* one bred male had a strong pair of median marginal bristles and no differentiated marginal row. 68% of the females in the same lot had a strong central pair of bristles and a weak marginal row; several flies had the central pair no stronger than the remaining bristles of the marginal row. Again in another lot of bred material of 7 females two exhibited this latter condition of having the central pair no stronger than the others.

This variation is important because the presence of a pair of strong median marginal macrochaetae has always been attributed by writers to *L. sylvarum* and here it is shown that the character may vary to quite a considerable extent.

In most cases the central pair were of about the same strength as the remaining bristles. As a rule, however, these

two bristles stood out at right angles, or at least at a considerable angle, to the longitudinal plane of the abdomen; whereas the remaining bristles were barely elevated and extended over the dorsum of the third segment. Thus these central bristles stood out as two distinct macrochaetae. It not infrequently happened however that these central bristles were not elevated and hence they could not be readily distinguished from the others of the marginal row and inference was naturally drawn that they were not present. Their presence could usually be detected by examining the sites of their insertions as compared with those of the remaining bristles; the central pair had their insertions very slightly anterior to the row of marginal macrochaetae.

The tegulae varied, as in *L. sericata*, from white to smoky; in one lot of bred material particularly an excellent gradational series, in respect to this character, was obtained.

The apex of the first posterior cell of the wings was, unlike the condition in *L. sericata* or *L. caesar*, longer than the anterior cross vein. This character is best seen from the under surface of the wing. It is apparently one of the best for separating this species from *L. sericata*. There was often a short spur at the angle of the fourth longitudinal vein.

#### RESUME OF *L. CAESAR*.

In all cases there were three strong pairs of dorsocentral bristles and there was no rudimentary or vestigial fourth pair.

In all cases but one, two pairs of postacrostichal bristles were found to be present. In this one exception there was an extra pair erratically placed.

The humeral bristles varied considerably. In the bred specimens there were two flies with two pairs and one fly with three pairs. The most common condition was two pairs, but there were a number of specimens with an extra anterior bristle on each side, and again others with a complete anterior fourth pair. At the other extreme there was a fly with two bristles on one side and three on the other. There was thus greater inconstancy of humeral bristles in this species than in either of the other two. It is interesting to note that it was always, as in *L. sericata* and *L. sylvarum*, the anterior bristles and of these the interior pair that were subject to variation.

The sternopleural bristles were represented in all cases but one by the normal three pairs. In this one exception the anterior bristle on one side was reduced to a long hair. It was the anterior bristle that became modified.

The ocellar bristles, as in the other two species, afforded secondary sexual characters.

The males had in all cases the one strong proclinate pair as in *L. sericata* and *L. sylvarum*, having insertion within the ocellar triangle. The females had the usual one strong pair having insertion within the ocellar triangle. The posterior pair were in most cases reduced to hairs, thus being less strong even than in *L. sylvarum*. There was one curious variation in which there were one strong pair and two very weak pairs of bristles; both these weak pairs were posterior to the strong anterior pair; one of them was inserted within and the other outside of the ocellar triangle. There were in addition to the bristles a number of hairs both within and outside of the triangle.

The color of the palpi was, in the specimens of this species examined, very constant. It was without exception amber yellow.

The width of front here again afforded a secondary sexual character. All the males had the front linear; it was considerably narrower than in *L. sylvarum*, and very considerably narrower than in *L. sericata*. In the females the width of front varied from three tenths to one third head width; the more general condition however was about three tenths, or the same as in *L. sylvarum*.

The color of the dorsum of the first abdominal segment varied from that of the remaining segments (abdomen unicolorous) to black. Between these two extremes there were numerous gradational variations; the most common of these was that in which the segment was somewhat darker, especially centrally, than the remaining segments.

As to the color of the tegulae there were found to exist the same variations as in *L. sylvarum* and *L. caesar*. The extremes were white and brown and between these were found numerous combinations. The more common condition was that of 'tinged brown.'

Regarding the last character, namely, the comparison in lengths of the apex of the first posterior cell and anterior cross

vein it was found that this species comes in this respect midway between *sericata* and *sylvarum*. In four cases the apical margin of the first posterior cell was slightly shorter than the length of the anterior cross vein, which is the typical condition in the case of *L. sericata*. In the remaining twenty seven flies it was about equal to the length of the anterior cross vein. Thus for this species the character will not serve to differentiate from the other two species.

Having completed the résumés for the three species of *Lucilia* the opportunity may be taken to make a few general remarks on characters which have not been made use of in the tables.

First, as to size, there was found to be little difference in the three species. Possibly *caesar* is generally somewhat larger than the other two. In each species there is however a considerable variation. To illustrate this it may be said that in over 200 specimens of *sericata* the smallest fly was 5 mm. long and the largest 9 mm.; the average length was from 7 to 8 mm.

Then as to general color there was again a great range of variation. Hough makes remark\* that 'In all the Calliphorineae of metallic color the shade varies through violet, green, blue and copper color.' One has only to look at a long series of *Lucilia* to find that, in this genus at least, the remark holds true. Generally, however, flies of *L. sericata* are brighter, owing to a greater preponderance of the coppery color, then are those of *L. caesar* and *L. sylvarum*.

Lastly a word may be said regarding the positions of the dorsocentral and postacrostichal bristles both in relation to the respective series separately and in relation to one another. As to the positions in their respective series it was found that they were placed, almost without exception, in the same plane longitudinally (cephalad-caudad) although there was variation. Then as to the relative positions of the dorsocentrals and postacrostichals there was found to exist a considerable variation: taking any four bristles transversely an imaginary line drawn through their insertions usually approached a straight line; this line was however scarcely ever absolutely straight and the deviations from it did not follow any definite plan. The

---

\*Synopsis of the Calliphorineae of the U. S., Zool. Bull., Vol. II, No. 6, Sept., 1899, p. 283.

accompanying diagram showing the positions of these thoracic bristles in the case of seven flies all bred from a single parent indicate this variation better than can any description.

The point is of interest on account of the fact that Mr. Townsend (loc. cit. p. 121) in describing a new species of *Lucilia* (*L. giraulti*) makes use of the relative positions of the postacrostichal and dorsocentral bristles.

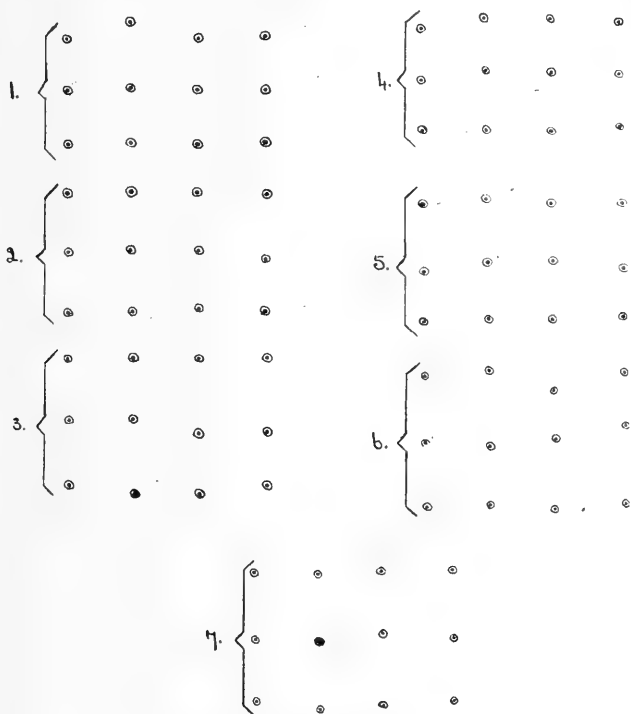

DIAGRAM

Showing variation in relative position of dorsocentral and postacrostichal bristles in the case of 7 specimens of *L. sericata*, all bred from the same parent fly.

Legend:

Each dot within a circle represents the insertion of a bristle.

Each bracketed group (of the total 7) represents the dorsocentral and postacrostichal bristles of one fly.

The two outside rows of bristles are dorsocentrals.

The two inside rows of bristles are postacrostichals.

The chief value of this study in variation lies in the fact that each species dealt with was found to be subject to considerable variation in the matter of chaetotaxy, color, size, etc. Also in that all the new characters used by Mr. Townsend (loc.

cit.) for the erection of the ten supposedly distinct species are shown to come within the limits of variation of the North American species of *Lucilia* as recognized by Hough.

NOTES ON THE TYPES AND CO-TYPES OF LUCILIA SPECIES IN THE  
U. S. NATIONAL MUSEUM.

The following notes were made in 1911, through the courtesy of the U. S. N. Museum authorities, on the types and cotypes of Mr. Townsend's supposedly new species of *Lucilia*. In some cases the Taxonomy of Muscoidean Flies, Smithsonian Misc. Col., Vol. 41, No. 1803, notes refer to the original descriptions. The value of certain characters employed in these descriptions is discussed in the preceding portion of this paper.

*Lucilia morilli*. Town.

The type specimen together with all the co-types are *Pseudopyrellia cornicina* Fab. There are no hypopleural bristles and the fourth vein is curved and not angular.

*Lucilia nigripalpis*. Town.

The type specimen must be referred to *L. sylvarum* Meig. The width of front is slightly less than one-third head width; the palpi are blackish; the first segment of the abdomen is blackish; on the second segment of the abdomen there is a well marked pair of median marginal macrochaetae quite as strong as are found in most specimens of *L. sylvarum*. The abdomen is however 'dented' in consequence of which the macrochaetae are appressed against it and this is presumably the reason that they were overlooked by the author of the species; there is a weak pair of extra ocellar bristles just posterior to the ocellar triangle and quite typical of *sylvarum*; in the comparative lengths of the apex of the first posterior cell and the anterior cross vein the fly is typically *sylvarum*.

The co-type is an undeveloped specimen of *L. sylvarum* Meig; the head characters are all typical except in the color of the palpi which are distinctly brownish, especially toward the base; the lower side however of the abdomen and also the legs both show this light color which means that the fly was captured soon after issuing; toward the tip the palpi become blackish and this is carried down one fourth distance to base; as to marginal macrochaetae on the abdomen there is a weak pair on the second segment which show up better when the fly is examined from the dorsal side; when the specimen is viewed laterally there is seen to be one other bristle near the center of the same segment; it is about as long as the shorter of the central pair but the base is weaker.



*Lucilia angustifrons*. Town.

The type specimen is a ♂ from England and the single co-type is a ♀ from Kaslo, B. C., which "seems to be this form" (Townsend, Taxonomy of Muscoidean Flies, p. 120). An examination of the type shows that a third and anterior pair of postacrostichal bristles is present; at the same time both these bristles are weaker than those situated posterior to them in the same rows and moreover the bristle on one side is decidedly less strong than that on the other side (the one on left side is weaker). This is the only character that separates the fly from typical *L. caesar* and as in this very character there is an irregularity it seems highly probable that the pair of bristles is nothing but a sport in which case the form must be referred to *L. caesar* Linn.

As to the single co-type, the ♀ from Kaslo, this fly has two postacrostichal bristles on one side and three on the other with the anterior one weak; the fly is unquestionably *L. caesar* Linn.

*Lucilia giraulti*. Town.

One ♂ from Paris, Texas, no cotypes. In the original description of this species (Townsend, Taxonomy of Muscoidean Flies, p. 121) there is only one character mentioned that would separate the form from *L. sericata* Meig. which is that "a second pair of ocellar bristles is present." Even were this so the character would be insufficient in itself as the study of variation for *L. sericata*, brought out the fact that in this species there is occasionally developed a second pair of ocellar bristles. An examination of the specimen itself however shows that the bristles in question are *not* developed. The fly is therefore *L. sericata* Meig.

Another character used in the description of this species is the position of the postacrostichal bristles relative to the dorsocentrals. The study in variation brought out the fact that this character has no determinative value. The above specimen is badly mutilated.

*Lucilia barberi*. Town.

A discussion of this supposed species is hardly necessary. All the characters employed to separate the form are met with

in *L. sericata* Meig. An examination of the type specimen and also of four cotypes shows that the form may be referred to *L. sericata* Meig.

*Lucilia unicolor.*

Five ♀ specimens from New Mexico, Mexico and British Columbia. They are all *L. caesar* Linn. The second pair of ocellar bristles is fairly strong in the type specimen, but in the co-types there is variation and they become less strong, in any case all come within the limits of variation of *L. caesar*.

*Lucilia purpurea.* Town.

There is no character in the description of this form which serves to separate it from *L. caesar* Linn. In the description it is stated that "the whole body is purplish, strongly violet tinged, especially in the ♀." This is certainly somewhat of an unusual hue for *caesar*, but a series can be arranged from the U. S. N. Museum material showing all gradations from this form to almost pure green. An examination of the type and co-type shows that there are no structural characters separating the form from *L. caesar* and the name *purpurea* Town. must therefore sink.

*Lucilia australis.* Town.

Two ♀ ♀ from the southern states and one ♂ from Alaska. The type and one co-type, both from the southern states, must be referred to *L. pilatei*. Hough. The ♂ from Alaska agrees with *L. caesar* Linn. in everything except the width of front which appears to be very slightly greater than in *L. caesar*. This, however, is probably partly optical, as the inner margins of the eyes, in the region of the ocellar triangle, are blackish, and thus appear to be part of the front.

*Lucilia infuscata.* Town.

From the description (Townsend. Taxonomy of Muscoidean Flies, p. 123) it is evident that the ♂ ♂ are *L. caesar* Linn. as all the characters enumerated come within the limits of variation of that species.

The ♀ ♀ of which there are six, "can be told from *caesar* only by the narrower front and darker basal segment." As to the latter of these characters the study in variation for *L. caesar* brought out the fact that in that species the first segment

of the abdomen is not unicolorous with the other segments, but darker. As to the former character, i. e., the 'narrower front,' the more general condition met with in *caesar* as to width of front is less than one third head width, or to be more specific three tenths head width; *infusata* is described as having the front two-sevenths head width and the difference between three-tenths and two-sevenths is one-seventieth, which reduces the character as a differentiating one to an absurdity.

An examination of the type and co-type bears out the above remarks and proves the form to be *L. caesar* Linn. with the exception of one co-type which is *Phormia regina* Meig.

*Lucilia oculata*. Town.

Six ♂♂ and two ♀♀. The former are *L. caesar* Linn. and the latter are *L. pilatei* Hough. The author of *oculata* lays stress on the color of the face and antennae, which are described in this instance as brownish yellow instead of black. After examining the U. S. N. Museum *caesar* material the writer found that taking three specimens from England, one from Mexico and one from Connecticut an excellent gradational series could be made, showing transition from black to light reddish brown. In this connection it may be stated that the late Mr. D. W. Coquillett collected a specimen of *L. pilatei* Hough, in Washington, D. C., which exhibits some remarkable colorational features. The whole fly is quite light, especially the legs and venter, but it is distinctly 'shot' with green and blue, so that in different lights it takes on different colors; the parafacials are pale reddish yellow. It is the experience of the writer that, within certain limits, the earlier a specimen of *Lucilia* is captured after issuance the lighter will be the color.

The synonymy indicated in the above notes on the types and co-types of *Lucilia* species in the U. S. N. Museum may be listed as follows;

- Lucilia morilli*, Town = *Pseudopyrillia cornicina*, Fab.
- Lucilia nigripalpis* Town = *Lucilia sylvarum*, Meig.
- Lucilia angustifrons* Town = *Lucilia caesar*, Linn. (abnormal fly).
- Lucilia giraulti* Town = *Lucilia sericata* Meig.
- Lucilia barberi* Town = *Lucilia sericata* Meig.
- Lucilia unicolor* Town = *Lucilia caesar* Linn.
- Lucilia purpurea* Town = *Lucilia caesar* Linn.
- Lucilia australis* Town = *Lucilia caesar* Linn.
- Lucilia infusata* Town = *Lucilia caesar* Linn.
- Lucilia infusata* Town = (1 cotype) = *Phormia regina* Meig.
- Lucilia oculata* Town, male = *Lucilia caesar* Linn.
- Lucilia oculata* Town, female = *Lucilia pilatei*, Hough.

It may be stated that Mr. W. R. Thompson and the late Mr. D. W. Coquillett examined independently the above material and both gentlemen substantially confirmed the above synonymy. Before leaving the subject of synonymy the opportunity may be taken of making a few remarks on some species listed in Aldrich's catalogue of North American Diptera. As regards *Lucilia sylphida*, Bigot, a copy of the original description (Ann. Soc. Ent. de France 1877, p. 45,) which was furnished the writer through the courtesy of Prof. J. M. Aldrich, is as follows:

"17. *S. Sylphida* female (nov. sp?).

Viridi metallico. (Abdomen?) Antenn. segmento 3.0 secundo quadruplo longiore. Alis, vena 4a usque ad apicem primæ spinosa. Cicatrice subhumerali nigra. Facie, basi tantum, duobus macrochaetis munita. Antennis palpisque pallide testaceis. Fronte grisea, occipite utrinque, obscure ænescente, vitta nigra apice fulva, facie albida, genis pallidissime testaceis; calypttris albis; alis hyalinis basi, pallidissime testaceus; pedibus, fusco-nigra, femoribus, extrinsecus, parum æneis. (L'abdomen manquant, est ce bien une espece nouvelle?)"

In this brief description mention is made of none but generic characters and these in a most general way. The form is probably not a distinct species, but this can only be ascertained by an examination of the type. As to some of the other species:

*Lucilia mollis*, Walk.

Hough refers doubtfully to *Phormia regina*.

*Lucilia rufipalpis*, Jaen.

Hough refers to *Phormia regina*.

*Lucilia nobilis*, Meig.

Mr. Austen, of the British Museum, writes that this form is now generally considered to be synonymous with *L. sericata*.

*Lucilia sylphida*, Big.

Probably not a distinct form.

*Lucilia terræ-novæ*, Des.

Hough refers to *Phormia*.

## OBSERVATIONS ON THE CHÆTOTAXY OF CALLIPHORINÆ.\*

BY PHINEAS W. WHITING.

### LUCILIA.

In his "Synopsis of the Calliphorinæ (Diptera) of the United States" (Zool. Bull. 1899, Vol. 11, No. 6), Garry de Neuville Hough defines our species of *Lucilia* as follows:

- "Two postacrosticals. Front of male linear, of female one-third as wide as the head; abdomen unicolorous. *cesar* L.
- "Front of male not linear, at narrowest part about one-eighth as wide as the head; front of female about one-fourth as wide as the head; abdomen not unicolorous, first segment and hind margins of second and third blackish, contrasting strongly with the remainder *pilatei* nov. sp. [Hough]
- "Three postacrostalis. Palpi black; front of male very narrow, that of female about one-third as wide as the head; abdomen with two stout marginal macrochætæ on the second abdominal segment. *sylvarum* Meig.
- "Palpi yellow; front of male varies from one-eighth to one-sixth as wide as the head, that of female about one-third as wide as the head; second abdominal segment without marginal macrochætæ. *sericata* Meig."

Moreover, he says, "The chætotaxy is invariable for each species except for an occasional evident deformity, and it differs in the different species only in the number of achrostical bristles."

Observations were made on this subfamily during the past season and especial attention was given to the matter of chætotaxy in *Lucilia*. Thus some estimate may be obtained of the extent of deformity as it occurs in nature. Female flies of this genus, moreover, were obtained alive and set in cages containing fish, in order that their offspring might be obtained for the purpose of studying the range of variation in the progeny of the separate females. Each family probably represents the offspring of several males as copulation is frequent. The bristles studied comprise only the achrosticals and the dorso-centrals posterior to the transverse suture of the thorax, with the exception that in *L. sylvarum* the marginal bristles on the second abdominal segment were recorded as they showed considerable divergence from the normal condition recorded by Hough and are regarded as a specific character.

\*Contributions from the Entomological Laboratory of the Bussey Institution, Harvard University, No. 67.

The post-sutural dorso-centrals and achrosticals in *L. sericata* form a group of twelve in four rows of three each as shown in the diagram (Fig. 1). This arrangement is recorded as 3, 3, 3, 3, the separation into rows being denoted by commas.

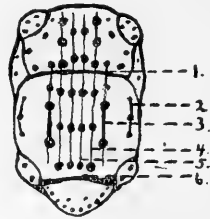

Fig. 1. Thorax of *Calliphora viridescens* to show typical arrangement of post sutural bristles.  
 1. Transverse suture. 2. Supra-alar bristles.  
 3. Intra-alar bristles. 4. Dorso-central bristles.  
 5. Post-acrostical bristles. 6. Scutellar suture.

When one or two of the anterior bristles of a row are omitted, the row is denoted by 2 or 1 respectively.

In order to denote the omission of the second or third bristle when those anterior to it are not omitted, the normal positions of the bristles are recorded as a, b, and c, from anterior to posterior. Thus a row lacking the second bristle would be called ac.

Addition of a supernumerary bristle into a row is denoted by ! inserted in the proper position between or in front of the letters denoting the normal bristles. Thus addition of a bristle in front of a row would be expressed by calling the row !abc. But in some cases the number of bristles alone was recorded for each row and the row was called 4 or 5, according to whether one or two bristles were added.

Insertion of a supernumerary bristle between the normal rows is denoted by parentheses enclosing a, b, or c, according to the position of the bristle from anterior to posterior. Thus a definition as 3, (a), 3, 3, 3, would denote the addition of a bristle between the first left post-dorso-central and the first left post-achrostical.

Additional bristles are usually smaller than the normal, but range all the way from microchaetæ to the size of the normal macrochaetæ. A small bristle is denoted by italics.

The records of wild flies are first noted, and these are followed by an account of the breeding experiments.

On July 29 the following were taken at meat near the Bussey Institution, Forest Hills, Mass.

<i>L. sericata</i> :	277 individuals—3, 3, 3, 3.	1 ♂ —3, 3, ab, 3.
	1 ♀ —5, 3, 3, 4.	1 ♀ —3, 2, 2, 4.
	4 ♀ ♀—3, 2, 2, 3.	2 ♀ ♀—3, 3, 2, 3.
	2 ♀ ♀—3, 3, 3, 4.	1 ♀ —3, 4, 3, 3.
	1 ♀ —3, 3, 4, 3.	1 ♂ —3, 2, 3, 3.

The frequent lack of anterior post-achrosticals either on one or on both sides is interesting as it denotes approach toward *L. caesar*. The general habitus, however, is typical *sericata*. A single specimen of *caesar* taken in this lot was 3, *abc*, *abc*, 3. Thus it appears that chaetotaxy alone cannot be relied upon to determine the species with certainty. This will appear from the following observations and even more clearly from the breeding experiments.

On Aug. 5, at meat at Bussey Institution, were taken:

<i>L. sericata</i> :	311 individuals—3, 3, 3, 3.	1 ♂—3, ac, 3, 3.
	1 ♂—3, 3, 2, 3.	1 ♀—3, 3, 2, 3.
	1 ♀—3, 3, ac, 3.	

*L. caesar*: 1 ♀—3, 2, 2, 3.

*L. sylvarum*: 1 ♀—3, 3, 3, 3, with two bristles on margin of second abdominal segment (for brevity written 2 ab. br.)

On Aug. 6, at meat at Bussey Institution, were taken:

<i>L. sericata</i> :	68—3, 3, 3, 3.	1 ♂—3, 2, 3, 3.
----------------------	----------------	-----------------

On Aug. 8, at the garbage scow, Boston, were taken at meat:

<i>L. sericata</i> :	955 individuals—3, 3, 3, 3.	1 ♂ —3, 3, ac, 3.
	1 ♂ —3, ac, 3, 3.	1 ♂ —3, 3, 2, 3.
	2 ♂ ♂—3, ab ! c, 3, 3.	1 ♀ —3, <i>abc</i> , 3, 3.
	1 ♀ —3, 1, 2, 3.	1 ♀ —3, ac, ac, 3.
	1 ♀ —4, 3, 3, 4.	1 ♀ —3, 3, 4, 4.
	1 ♀ —3, 4, 3, 3.	1 ♀ —3, 2, 1, 3.
	5 ♀ ♀—3, ac, 3, 3.	2 ♀ ♀—3, <i>abc</i> , 3, 3.
	3 ♀ ♀—3, 3, ac, 3.	3 ♀ ♀—3, 3, 2, 3.
	4 ♀ ♀—3, 2, 3, 3.	

Flies having the habitus of *caesar* were as follows:

5 ♂ ♂—3, 2, 2, 3.	9 ♀ ♀—3, 2, 2, 3.
1 ♀ —3, <i>abc</i> , 2, 3.	

On Aug. 9 at a short distance from Bussey Institution on leaves near a pond the following were taken:

<i>L. sericata</i> :	1 ♂ —3, 3, 3, 3.
<i>L. caesar</i> :	1 ♀ —3, 2, 2, 3.
<i>L. sylvarum</i> :	2 ♂ ♂—3, 3, 3, 3, with 2 ab. br.
	1 ♂ —3, 3, 2, 3, with 2 ab. br.
	4 ♀ ♀—3, 3, 3, 3, ab. br. lacking.

On Aug. 10 at same place the following were taken at meat:

<i>L. sericata</i> :	4 ♂ ♂—3, 3, 3, 3.	100 ♀ ♀—3, 3, 3, 3.
	2 ♀ ♀—3, 2, 2, 3.	2 ♀ ♀—3, a / bc, 3, 3.
	1 ♀ —3, (a), 3, 3, 3.	
<i>L. caesar</i> :	3 ♂ ♂—3, 2, 2, 3.	20 ♀ ♀—3, 2, 2, 3.
<i>L. sylvarum</i> :	1 ♂ —3, 3, 3, 3, with 2 ab. br.	
	1 ♀ —3, 3, 3, 3, with 2 ab. br.	

An indeterminate ♂ *Lucilia*—3, *abc*, *abc*, 3.

On Aug. 12, at same place on leaves were taken:

- L. sericata*: 1 ♀ —3, 3, 3, 3.  
*L. sylvarum*: 14 ♂♂—3, 3, 3, 3, with 2 ab. br.  
 2 ♂♂—3, 3, 3, 3, with 3 ab. br.  
 1 ♂ / —3, 3, 3, 3, with 4 ab. br.  
 1 ♂ —3, 3, a / bc, 3, with 2 ab. br.  
 1 ♀ —3, 3, a / bc, 3, with 2 weak ab. br.

On Aug. 14, at same place, on leaves were taken:

- L. sericata*: 1 ♀ —3, 3, 3, 3.  
*L. cæsar*: 4 ♀♀—3, 2, 2, 3.  
*L. sylvarum*: 5 ♂♂—3, 3, 3, 3, with 2 ab. br.  
 1 ♂ —3, 3, 2, 3, with 3 ab. br.  
 2 ♂♂—3, 3, 3, 3, with 4 ab. br.  
 1 ♂ —3, a / bc, ab / c, 3, with 2 ab. br.  
 3 ♀♀—3, 3, 3, 3, ab. br. lacking.

And at meat:

- L. cæsar*: 2 ♂♂—3, 2, 2, 3.  
 21 ♀♀—3, 2, 2, 3.  
*L. sericata*: 6 ♂♂—3, 3, 3, 3.  
 225 ♀♀—3, 3, 3, 3.  
 1 ♀ —3, 3, 3, / abc.  
 2 ♀♀—3, a / bc, 3, 3.  
 1 ♀ —3, 3, a / bc, 3.  
 1 ♀ —3, ac, 3, 3.  
*L. sylvarum*: 1 ♀ —3, 3, / abc, 3, with 2 weak ab. br.

On Aug. 15, in meadow near Bussey Institution were taken at meat:

- L. cæsar*: 1 ♂ —3, 2, 2, 3.  
*L. sericata*: 8 ♂♂—3, 3, 3, 3.  
 145 ♀♀—3, 3, 3, 3.  
 1 ♀ —3, 3, 3, / abc.  
 1 ♀ —3, a / bc, 3, 3.  
 1 ♀ —a / bc, 3, 3, 3.  
 1 ♀ —3, 3, a / bc, 3.

On Aug. 29, at Hartland, Vt., by the bank of the Connecticut River at some distance from any house were taken at meat:

- L. cæsar*: 1 ♂ —3, 2, 2, 3. 32 ♀♀—3, 2, 2, 3.  
 1 ♀ —3, 3, 2, 3.  
*L. sylvarum*: 3 ♀♀—3, 3, 3, 3, with 2 well developed ab. br.

On Oct. 17, at garbage scow, Boston, were taken at meat:

- L. sericata*: 28 ♂♂—3, 3, 3, 3. 351 ♀♀—3, 3, 3, 3.  
 1 ♂ —3, 2, 2, 3. 1 ♂ —3, 3, 2, 3.  
 1 ♀ —3, 2, 2, 3. 1 ♀ —3, 3, 2, 3.  
 1 ♀ —3, 2, abc, 3. 1 ♀ —3, 3, ac, 3.  
 1 ♀ —3, ac, ac, 3. 1 ♀ —3, 3, 3, ab / c.  
 1 ♀ —/ abc, 3, 3, / abc.

In all cases habitus rather than chætotaxy has been taken as the criterion of specific determination, and this I believe to be more reliable on account of my breeding experiments. By habitus I mean general coloration and slight differences of form which would be very hard to define verbally. The width of the front is also important here. The habits are also somewhat different, as may be seen from the observations. *L. sylvarum* appears to be the wildest form, being without excep-



tion taken at some distance from buildings. *Sericata* is more commonly present either inside or very near buildings, while *caesar* may be taken in either situation, but more frequently along with *sylvarum*. It would be of considerable interest to study the distribution of these species over a more extensive area.

In order to get an approximate estimation of the percentage of individuals abnormal in chaetotaxy, I have added the sericatas and find them as follows:

Normal—2,479 individuals. Abnormal by reduction—47 individuals or 2%. Abnormal by addition—23 individuals or 1%. Abnormal by reduction and addition—1 ♀—3,2, 2, 4, or .04%.

The variants by reduction are here 10 ♂♂ and 37 ♀♀, while the variants by addition are 2 ♂♂ and 22 ♀♀. The excess of females is of course due to the fact that the flies were taken at meat.

Some of the flies were bred to show the character of the progeny, and these showed results as follows:

*L. sylvarum*: ♀ —3, 3, a / bc, 3, with 2 very small ab. br., taken by pond near Bussey, Aug. 12, gave all females in progeny as follows:  
 9 ♀♀—3, 3, 3, 3, ab. br. lacking.  
 2 ♀♀—3, 3, 3, 3, with 2 small ab. br.  
 1 ♀ —3, / abc, 3, 3, ab. br. lacking.  
 3 ♀♀—3, 3, a / bc, 3, ab. br. lacking.  
 1 ♀ —3, / abc, / abc, 3, ab. br. lacking.

This suggests that an extra post-sutural bristle may be inherited.

*L. caesar*:

♀—3, 2, 2, 3, from Bussey Pond, Aug. 14, gave 18 ♂♂—3, 2, 2, 3.  
 13 ♀♀—3, 2, 2, 3. 1 ♂—3, b, 2, 3.  
 ♀—3, 2, 2, 3, from Bussey Pond, Aug. 10, gave 13 ♀♀—3, 2, 2, 3. No males.

*L. sericata*:

♀—3,3, 3, 3, from Bussey Institution, July, gave  
 51 ♂♂—3, 3, 3, 3.  
 35 ♀♀—3, 3, 3, 3. 1 ♀—3, 3, a / bc, 3.  
 ♀—3, 3, 3, 3, from Bussey Institution, Aug. 5, gave  
 71 ♂♂—3, 3, 3, 3. 59 ♀♀—3, 3, 3, 3.  
 3 ♂♂—3, 3, a / bc, 3. 2 ♂♂—3, a / bc, 3, 3.  
 1 ♂ —3, a / bc, a / bc, 3. 1 ♀ —3, a / bc, 3, 3.  
 1 ♀ —3, 3, a / bc, 3.  
 ♀—3, 2, 3, 3, from Bussey Institution, July, gave  
 32 ♂♂—3, 3, 3, 3. 32 ♀♀—3, 3, 3, 3.  
 3 ♀♀—/ abc, 3, 3, / abc.  
 1 ♀ —/ abc, / abc, 3, / abc.  
 1 ♀ —3, / abc, / a / bc, 3.  
 1 ♀ —/ abc, 3, 3, (a), 3.  
 1 ♀ —3, 3, / abc, 3. 1 ♂ —3, 3, ac, 3.  
 1 ♂ —/ abc, 3, 3, / abc. 1 ♂ —3, (c), 3, 3, 3.  
 1 ♂ —3, 3, 2, 3. 1 ♂ —3, 3, 3, / abc.

- ♀—3, 3, 3, 3, from Bussey Institution, July, gave
- |                          |                            |
|--------------------------|----------------------------|
| 78 ♂♂—3, 3, 3, 3.        | 110 ♀♀—3, 3, 3, 3.         |
| 1 ♂ —3, 3, ab, 3.        | 1 ♂ —3, 2, ac, 3.          |
| 4 ♂♂—3, 2, 3, 3.         | 1 ♂ —3, 2, 2, 3.           |
| 1 ♂ —3, (a), 3, 3, 3.    | 1 ♂ —3, a / bc, a / bc, 3. |
| 1 ♀ —3, 3, ac, 3.        | 1 ♀ —3, 3, 3, / abc.       |
| 1 ♀ —/ abc, 3, 3, / abc. | 1 ♀ —/ abc, 3, 3, 3.       |
| 1 ♀ —3, a / bc, 3, 3.    |                            |
- ♀—3, 3, 3, 3, from Bussey, July, gave:\*
- |                   |                   |
|-------------------|-------------------|
| 30 ♂♂—3, 3, 3, 3. | 34 ♀♀—3, 3, 3, 3. |
| 1 ♂ —3, ac, 3, 3. |                   |
- 2 ♀♀—3, 3, 3, 3, taken at Bussey Institution, gave:
- |                    |                    |
|--------------------|--------------------|
| 191 ♂♂—3, 3, 3, 3. | 203 ♀♀—3, 3, 3, 3. |
| 2 ♂♂—3, ac, 3, 3.  | 3 ♂♂—3, 2, 3, 3.   |
| 2 ♂♂—3, 3, 2, 3.   | 1 ♂ —3, ab, 3, 3.  |
| 1 ♂ —3, 3, ac, 3.  | 1 ♀ —3, 2, 2, 3.   |
| 1 ♂ —3, ac, 2, 3.  |                    |
- 1 ♀—3, 3, 3, 3, from Bussey Institution, Nov. 20, gave:
- |                    |                    |
|--------------------|--------------------|
| 124 ♂♂—3, 3, 3, 3. | 118 ♀♀—3, 3, 3, 3. |
| 1 ♀ —3, 3, 2, 3.   | 1 ♂ —3, 2, 3, 3.   |
| 1 ♂ —3, ac, 3, 3.  |                    |
- 1 ♀ —3, 3, 3, 3, from Bussey Institution, Nov. 18, gave:
- |                       |                       |
|-----------------------|-----------------------|
| 25 ♂♂—3, 3, 3, 3.     | 34 ♀♀—3, 3, 3, 3.     |
| 2 ♀♀—3, 3, ac, 3.     | 1 ♀ —3, ac, 3, 3.     |
| 1 ♀ —3, a / bc, 3, 3. | 1 ♂ —a / bc, 3, 3, 3. |
- 1 ♀—3, 3, 3, 3, from scow, Boston, Aug. 8, gave:
- |                       |                   |
|-----------------------|-------------------|
| 17 ♂♂—3, 3, 3, 3.     | 19 ♀♀—3, 3, 3, 3. |
| 1 ♀ —3, 3, a / bc, 3. |                   |

Thus the progeny of normal ♀♀ (3, 3, 3, 3) show considerable variation, and it is readily observed that this variation tends in some cases to reduction of bristles, in other cases to addition of bristles, while both tendencies may be observed in the same family. Taking the totals of these families we have normal ♂♂ 589, normal ♀♀ 410, variants by addition, 12 ♂♂ and 16 ♀♀; and variants by reduction, 21 ♂♂ and 6 ♀♀. This gives 2.6% variants by addition and 2.5% variants by reduction.

Let us now consider the families of *L. sericata* produced by mothers abnormal by reduction.

- ♂ and ♀—3, 3, 2, 3, taken at scow, Boston, Oct. 17, put in same box, gave:
- |                    |                   |
|--------------------|-------------------|
| 13 ♂♂—3, 3, 3, 3.  | 8 ♀♀—3, 3, 3, 3.  |
| 1 ♂ —3, 3, 2, 3.   | 1 ♂ —3, ac, 3, 3. |
| 1 ♂ —3, ac, ac, 3. | 1 ♂ —3, 3, 2, 3.  |
| 2 ♀♀—3, 2, 3, 3.   |                   |
- ♀—3, 2, 3, 3, taken at scow, Boston, Aug. 8, gave:
- |                   |                   |
|-------------------|-------------------|
| 32 ♂♂—3, 3, 3, 3. | 22 ♀♀—3, 3, 3, 3. |
| 1 ♂ —3, ac, 3, 3. | 1 ♂ —3, 3, ac, 3. |
| 1 ♂ —3, 3, ab, 3. | 1 ♂ —3, 2, 3, 3.  |
| 1 ♂ —3, ac, 2, 3. |                   |

\*By reason of an imperfection in the technique at this point, this culture may have been contaminated from flies outside. The results are therefore, not averaged in with the total.

- ♀-3, 3, ac, 3, from scow, Boston, Aug. 8, gave 12 ♂♂-3, 3, 3, 3.  
 15 ♀♀-3, 3, 3, 3.  
 ♀-3, ac, 2, 3, from Bussey Institution, July, gave:  
 18 ♂♂-3, 3, 3, 3. 8 ♀♀-3, 3, 3, 3.  
 ♀-3, 2, 3, 3, from scow, Boston, Aug. 8, gave:  
 10 ♂♂-3, 3, 3, 3. 14 ♀♀-3, 3, 3, 3.  
 1 ♂ -3, 3, 2, 3. 1 ♂ -3, ac, 3, 3.  
 1 ♀ -3, ac, ac, 3.  
 ♀-3, 2, 1, 3, from scow, Boston, Aug. 8, gave 10 ♂♂-3, 3, 3, 3. 12 ♀♀-3, 3, 3, 3. This family was continued into the third generation and will be considered below.  
 ♀-3, ac, 3, 3, from scow, Boston, Aug. 8, gave:  
 7 ♂♂-3, 3, 3, 3. 7 ♀♀-3, 3, 3, 3.  
 1 ♀ -3, 3, a / bc, 3.

Taking the totals of these families of females deficient in bristles we find normal ♂♂ 102, normal ♀♀ 86, variants by reduction 10 ♂♂ and 4 ♀♀, variants by addition, 1 ♀. Thus from these rather small numbers we see the variants by reduction are 7%, while the variants by addition are 0.5%.

Let us consider now the progeny of females abnormal by addition of bristles.

- ♀- / abc, 3, 3, / abc, from scow, Boston, Oct. 17, gave:  
 30 ♂♂-3, 3, 3, 3. 21 ♀♀-3, 3, 3, 3.  
 1 ♂ -3, (a), 3, 3, (a), 3.  
 ♀-3, 3, 3, ab ! c, from scow, Boston, Oct. 17, gave:  
 9 ♂♂-3, 3, 3, 3. 20 ♀♀-3, 3, 3, 3.  
 1 ♂ -3, 3, 3, (a), 3. 1 ♂ -3, ac, 3, 3.  
 1 ♀ -3, ac, ac, 3.  
 ♀-3, 3, a / bc, / abc, from scow, Boston, Aug. 8, gave:  
 40 ♂♂-3, 3, 3, 3. 32 ♀♀-3, 3, 3, 3.  
 3 ♂♂-3 a ! bc, 3, 3. 1 ♂-3, 3, a ! bc, 3.  
 1 ♂-3, (a), 3, 3, 3. 1 ♂ -3, ac, ac, 3.  
 1 ♀ -3, 3, a / b ! c, 3. 2 ♀♀-3, a ! bc, 3, 3.  
 1 ♀ -3, 3, ac, 3. 1 ♀ -3, ab, 3, 3.  
 1 ♀ -3, 3, 2, 3. 1 ♀ -3, ac, 3, 3.  
 ♀-a / bc, a / bc, 3, 3, from scow, Boston, Aug. 8, gave:  
 75 ♂♂-3, 3, 3, 3. 52 ♀♀-3, 3, 3, 3.  
 1 ♂ -3, 3, a / bc, 3. 1 ♂ -3 (a), 3, 3, 3.  
 1 ♂ -3, a / bc, 3, 3. 2 ♀♀-3, a / bc, 3, 3.  
 2 ♀♀-3, 3, a / bc, 3. 1 ♀ -3, 3, 3, a / bc.

Taking the totals of these families of females abnormal by addition of bristles we find normal ♂♂ 154, normal ♀♀ 125, variants by reduction, 2 ♂♂ and 5 ♀♀; variants by addition, 10 ♂♂ and 8 ♀♀. Thus the variants by reduction are 2.3% while the variants by addition are 6%.

From the averages of the reared stock we see there is a tendency to vary both toward reduction and toward addition of bristles and that this tendency is evidently of a hereditary character, the mean being shifted in the direction of the parental abnormality.

The female of *L. sericata* (3, 2, 1, 3.) taken at the garbage scow, Boston, August 8, gave as above recorded 10 ♂♂—3, 3, 3, 3, and 12 ♀♀—3, 3, 3, 3. Three pairs of these were segregated and gave offspring as follows:

1st pair gave:		
10 ♂♂—3, 3, 3, 3.		7 ♀♀—3, 3, 3, 3.
2d pair gave:		
42 ♂♂—3, 3, 3, 3.		39 ♀♀—3, 3, 3, 3.
1 ♂ —ac, 3, 3, ac.		2 ♂♂—3, ! abc, 3, 3.
1 ♂ —3, 2, 3, 3.		1 ♀ —3, ac, ac, 3.
1 ♀ —3, ac, 3, 3.		
3d pair gave:		
55 ♂♂—3, 3, 3, 3.		62 ♀♀—3, 3, 3, 3.
7 ♂♂—3, 2, 2, 3.		1 ♀ —3, 2, 2, 3.
2 ♂♂—3, 3, 2, 3.		3 ♀♀—3, 2, 3, 3.
1 ♂ —3, 3, 3, ac.		1 ♀ —3, abc, 3, 3.
1 ♂ —3, a ! bc, 3, 3.		1 ♀ —3, abc, 2, 3.
1 ♀ —2, 3, 3, 3.		1 ♀ —3, 3, ac, 3.
1 ♀ —3, ab, 3, 3.		

Of the progeny of the first pair 1 ♂—3, 3, 3, 3, was mated to 2 ♀♀—3, 3, 3, 3, and produced offspring as follows:

163 ♂♂—3, 3, 3, 3.	170 ♀♀—3, 3, 3, 3.
2 ♂♂—3, ac, 3, 3.	2 ♀♀—3; ac, 3, 3.
2 ♂♂—3, 3, ac, 3.	1 ♀ —2, 3, 3, 3.
1 ♂ —3, 3, 2, 3.	1 ♀ —ac, 3, 3, 2.
1 ♂ —With very few scattered bristles.	1 ♀ —ac, 3, 2, 0.
1 ♂ —3, a ! bc, 3, 3.	1 ♀ —ab, 3, ab, bc.
1 ♂ —3, 3, a ! bc, 3.	2 ♀♀—3, a ! bc, 3, 3.
1 ♀ —3, 3, a ! bc, 3.	2 ♀♀—3, 3, a ! bc, 3.
1 ♀ —a ! bc, 3, 3, 3.	1 ♀ —! abc, 3, 3, ! abc.

Of the progeny of the second pair 1 ♂—3, 3, 3, 3, was mated to 1 ♀—3, 3, 3, 3, and produced the following:

92 ♂♂—3, 3, 3, 3.	85 ♀♀—3, 3, 3, 3.
2 ♂♂—3, a ! bc, a ! bc, 3.	5 ♂♂—3, a ! bc, 3, 3.
4 ♂♂—3, 3, a ! bc, 3.	3 ♀♀—3, a ! bc, 3, 3.
1 ♀ —3, 3, a ! bc, 3.	1 ♀ —3, ac, 3, 3.

If we take the totals of this inbred stock we find them as follows:

362 ♂♂—3, 3, 3, 3.	363 ♀♀—3, 3, 3, 3.
By reduction, 18 ♂♂ and 18 ♀♀ or 5%.	
By addition, 16 ♂♂ and 11 ♀♀ or 3.7%.	

In the spring of 1912 a few specimens of *Calliphora vomitoria* L. and *C. viridescens* Desv. were taken at Cambridge and *C. erythrocephala* Meig was common all through the summer. In the fall *vomitoria* and *viridescens* appeared in considerable numbers in the vicinity of the Bussey Institution. The

records of chaetotaxy of the wild *Calliphorae* that was taken at Bussey are as follows. The bristles observed are the post-achrosticals and post-dorso-centrals as in *Lucilia*.

*C. erythrocephala*:

33 ♂♂—3, 3, 3, 3.      134 ♀♀—3, 3, 3, 3.  
1 ♀ —3, 3, a ! bc, 3.      1 ♀ —2, 3, 3, 3.

*C. vomitoria*:

2 ♂♂—3, 3, 3, 3.      54 ♀♀—3, 3, 3, 3.

*C. viridescens*:

21 ♀♀—3, 3, 3, 3.      1 ♀ —3, ab, 3, 3.

These records show 3 abnormal males out of 247, but the ratio is not very significant as the numbers are very small.

The records of breeding *Calliphorae* show rather interesting results.

A ♀ *erythrocephala*—3, 3, 3, 3, gave:

54 ♂♂—3, 3, 3, 3.      47 ♀♀—3, 3, 3, 3.  
2 ♂♂—3, a ! bc, 3, 3.

One of these abnormal males was mated to his sister and the pair gave the following offspring:

131 ♂♂—3, 3, 3, 3.      86 ♀♀—3, 3, 3, 3.  
1 ♂ —3, (a), 3, 3, 3.      1 ♀ —3, a ! bc, aabc, 3.  
4 ♂♂—3, a ! bc, 3, 3.      5 ♀♀—3, 3, a ! bc, 3.  
1 ♂ —3, a ! bc, a ! bc, 3.      1 ♀ —3, 3, 3, ab.  
8 ♂♂—3, 3, a ! bc, 3.  
1 ♂ —3, ab, 3, 3.

Another wild ♀ *erythrocephala*—3, 3, 3, 3, gave:

80 ♂♂—3, 3, 3, 3.      74 ♀♀—3, 3, 3, 3.

Another wild ♀ *erythrocephala*—3, 3, 3, 3, gave:

97 ♂♂—3, 3, 3, 3.      97 ♀♀—3, 3, 3, 3.  
2 ♀♀—3, 3, ac, 3.

A ♀ *vomitoria*—3, 3, 3, 3, gave:

47 ♂♂—3, 3, 3, 3.      64 ♀♀—3, 3, 3, 3.  
4 ♂♂—3, ac, 3, 3.      4 ♀♀—3, ac, 3, 3.  
2 ♂♂—3, 3, ac, 3.      4 ♀♀—3, 3, ac, 3.  
1 ♂ —3, 3, ab, 3.      1 ♀ —3, 2, 3, 3.  
1 ♂ —3, 3, 2, 3.

Another ♀ *vomitoria*—3, 3, 3, 3, gave:

32 ♂♂—3, 3, 3, 3.      64 ♀♀—3, 3, 3, 3.  
1 ♂ —ab, 3, 3, 3.      2 ♂♂—3, a ! bc, 3, 3.  
1 ♂ —3, 2, 3, 3.      1 ♀—3, / abc, / abc, 3.  
1 ♂ —3, 2, 2, 3.

A ♀ *viridescens*—3, 3, 3, 3, gave:

5 ♂♂—3, 3, 3, 3.      5 ♀♀—3, 3, 3, 3.  
1 ♂ —3, 2, 3, 3.      1 ♀ —3, ac, 3, 3.

Another ♀ *viridescens*—3, ab, 3, 3, gave:

4 ♂♂—3, 3, 3, 3.      6 ♀♀—3, 3, 3, 3.  
1 ♂ —3, ac, ac, 3.

The totals of the bred stock for the three species are:

450 ♂♂—3, 3, 3, 3.      443 ♀♀—3, 3, 3, 3.

By reduction 14 ♂♂ and 4 ♀♀, or 2%; by addition 18 ♂♂ and 12 ♀♀ or 3%.

In the course of collecting Calliphoræ four specimens were obtained which I was unable to classify as belonging to any one of the three species common in Massachusetts. They appeared like inter-grades between *erythrocephala* and *viridescens*.

One small sized male had the beard black, the right cheek dark red, and the left cheek somewhat lighter in color. The right cheek was dark enough to place the specimen as *viridescens* but the left cheek resembled that of *erythrocephala*. One small and two large sized females answer also to the same description. In all four cases the right cheek is considerably darker than the left. The flies were examined by Mr. C. W. Johnson who was unable to classify them.

The meaning of these forms is uncertain and I should not feel justified in advancing an hypothesis without first performing breeding experiments with them.

#### SUMMARY AND CONCLUSIONS.

A number of meat flies of the Calliphorine genera, *Lucilia* and *Calliphora*, were collected during the summer and fall of 1912 and observations were made on the range of variation in the chaetotaxy. The bristles studied were the post-sutural achrosticals and dorso-centrals of the thorax. Breeding experiments were also performed in order to study the range of variation in the individual families.

Especial attention was given to *Lucilia sericata*. The following table gives the general results of the work on this species.

Wild Flies Captured	Normal		Abnormal by reduct'n				Abnormal by addition		
	2,479		Number 47		Percentage 2		Number 23		Percentage 1
	♂♂	♀♀	♂♂	♀♀		♂♂	♀♀		
Progeny of normal ♀♀	589	410	21	6	2.5	12	16		2.6
Progeny of ♀♀ abnormal by reduction	102	86	10	4	7	0	1		0.5
Progeny of ♀♀ abnormal by addition	154	125	2	5	2.3	10	8		6

As regards the wild flies captured it will be observed that there are twice as many abnormal by reduction as there are abnormal by addition. Too much importance should not be attached to this fact, as it may be due to an error. In a few cases there is reduction in the size of the bristle normally present, but as a general thing there is no reduction unless the bristle is entirely absent. On the other hand a very small bristle is frequently added and it is more rarely the case that a supernumerary bristle is of the full size. In looking over a large number of flies rapidly, one would then have a tendency to overlook the presence of the small additional bristle and to record more reduction than addition in number. As these flies were examined for the purpose of finding breeding material, careful attention was not given to this matter and I am inclined to consider the normal range of variation to be somewhat above two per cent both in the direction of reduction and in the direction of addition. This equality of variation in both directions is seen in the progeny of normal females. In the progeny of females abnormal by reduction and of females abnormal by addition, the variation of the offspring is seen to tend in the direction of the parental abnormality.

A single female lacking three bristles, (3, 2, 1, 3), gave ten males and twelve females of normal chaetotaxy. Three pairs of these gave 215 normal flies, 23 abnormal by reduction, and 3 abnormal by addition. A pair and a trio of these normals gave in the third generation from the original female, 510 normals, 13 abnormal by reduction, and 24 abnormal by addition. This shows regression away from the abnormal and suggests Galton's Law.

Observations made on *Lucilia sylvarum* and *caesar*, and on *Calliphora erythrocephala*, *viridescens*, and *vomitorea* lead me to believe that these five species are analogous to *Lucilia sericata* in the variation of their chaetotaxy.

In conclusion I wish to express my thanks for suggestions and criticism in the course of the work kindly offered by Professor Wheeler, Professor Castle and Mr. Brues.

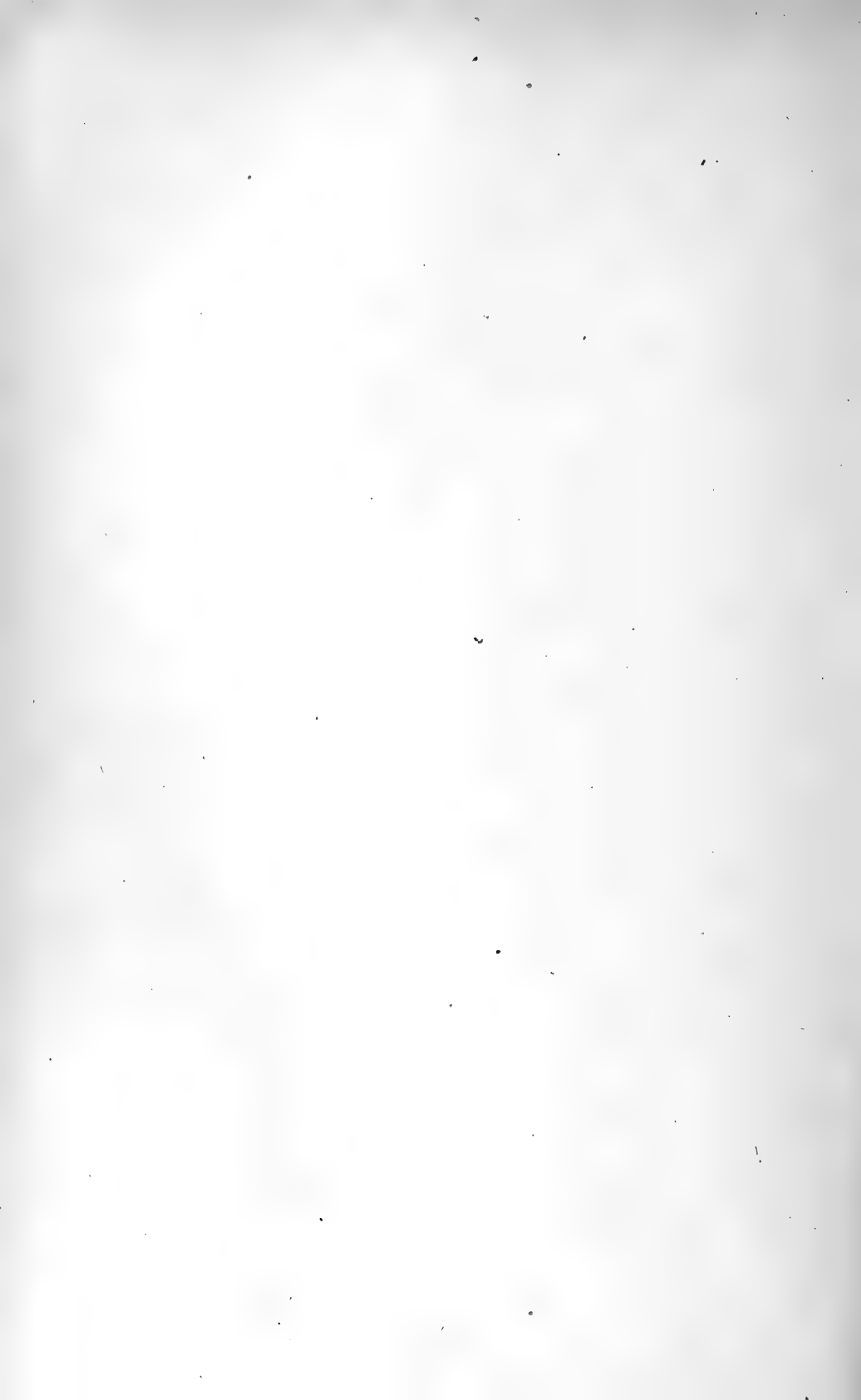



## NOTICE TO MEMBERS AND CONTRIBUTORS.

---

The Annals of the Entomological Society of America, published by the Society quarterly, includes the Proceedings of the Annual meetings and such papers as may be selected by the Editorial Board.

Papers may be submitted to any member of the Editorial Board and should be as nearly as possible in the form desired as final, preferably typewritten, and illustrations must be finished complete ready for reproduction. Plates must not exceed 5x7 inches unless intended to fold. In general, papers to be accepted must be original, complete and previously unpublished and, except in connection with the proceedings, it will not be the policy to publish preliminary announcements or notes. Authors will be allowed fifty reprints gratis and additional copies at cost to the Society.

The Managing Editor is provided with the most recent address of all members on record in the Secretary's office for mailing the numbers of the Annals and hereafter members complaining of the non-receipt of numbers must present their complaint to the Secretary within four months from the date of the mailing of the issue. After that time the numbers will be furnished only at the regular published rate.

Requests for information as to membership and the annual subscription and dues of members may be sent to the Secretary-Treasurer, A. D. MacGillivray, 603 Michigan Ave., Urbana, Ill.

Communications relating to the ANNALS, and all orders for separate copies or reprints should be addressed to the Managing Editor or to

ANNALS OF THE ENTOMOLOGICAL SOCIETY OF AMERICA,  
Biological Building, State Univ., Columbus, Ohio.

## CONTENTS OF THIS NUMBER.

---

CROSBY, C. R.—A Revision of the North American Species of <i>Megastigmus</i> Dalman.....	155
BANKS, NATHAN—The Neuropterous Genus <i>Palpares</i> .	171
BRAIN, CHAS. K.— <i>Stomoxys Calcitrans</i> Linn., Part II	197
SMITH, LUCY WRIGHT—The Biology of <i>Perla Immarginata</i> Say.....	203
SHELFORD, VICTOR E.—The Life-History of a Bee-Fly ( <i>Spogostylum Anale</i> Say) Parasite of the Larva of a Tiger Beetle ( <i>Cicindela Scutellaris</i> Say Var. <i>Lecontei</i> Hald.).....	213
TOWNSEND, CHARLES H. T.—A New Application of Taxonomic Principles.....	226
PATCH, EDITH M.—A Study in Antennal Variation..	233
TOTHILL, JOHN D.—A Study in Variation in the North American Greenbottle Flies of the Genus <i>Lucilia</i> , with Systematic Notes on the Species Involved.....	241
WHITING, PHINEAS W.—Observations on the Chaetotaxy of Calliphorinae.....	257

---

The regular annual subscription price for the ANNALS is in the United States, Cuba, Porto Rico, Hawaii and Mexico, \$3.00; Canada, \$3.50; other countries, \$4.00. Checks, drafts or money orders should be drawn payable to ANNALS ENTOMOLOGICAL SOCIETY OF AMERICA, and addressed to Biological Building, State Univ., Columbus, Ohio, U. S. A.

ANNALS  
OF  
The Entomological Society of America

---

SEPTEMBER, 1913

---

EDITORIAL BOARD

J. H. COMSTOCK,  
ITHACA, N. Y.

L. O. HOWARD,  
WASHINGTON, D. C.

C. J. S. BETHUNE,  
GUELPH, ONTARIO, CANADA.

W. M. WHEELER,  
BOSTON, MASS.

C. W. JOHNSON,  
BOSTON, MASS.

P. P. CALVERT,  
PHILADELPHIA, PA.

V. L. KELLOGG,  
STANFORD UNIV., CAL.

J. W. FOLSOM,  
URBANA, ILLS.

HERBERT OSBORN, Managing Editor,  
COLUMBUS, OHIO.

---

PUBLISHED QUARTERLY BY THE SOCIETY  
COLUMBUS, OHIO

---

---

Entered as second class matter April 11, 1908, at the Post Office at Columbus, Ohio,  
under the Act of Congress of March 3, 1879.



# The Entomological Society of America.

FOUNDED 1906.

## OFFICERS 1913.

- President*—C. J. S. BETHUNE .....Guelph, Ont., Canada  
*First Vice-President*—P. P. CALVERT.....Philadelphia, Pennsylvania  
*Second Vice-President*—WM. S. MARSHALL .....Madison, Wisconsin  
*Secretary-Treasurer*—A. D. MACGILLIVRAY.....Urbana, Illinois  
*Executive Committee*—THE OFFICERS, and HERBERT OSBORN, C. P. GILLETTE,  
V. L. KELLOGG, J. G. NEEDHAM, C. T. BRUES, NATHAN BANKS.  
*Committee on Nomenclature*—H. T. FERNALD, E. P. FELT, T. D. A. COCKERELL.

## Price List of Publications.

Annals, Vols. I, II, III, IV and V, complete, each.....	\$3.00
Annals, Separate Parts except as below, each .....	1.00
Annals, Vols. I and II, Part 3, each.....	.50
Annals, Vol. IV, Part IV, each.....	1.50

## REPRINTS FROM VOLUME I.

Proceedings of first three meetings; Constitution, By-Laws and List of Members.....	.25
WHEELER, WM. M.—Polymorphism of Ants.....	.30
OSBORN, HERBERT—The Habits of Insects as a Factor in Classification.....	.20
SEVERIN, H. H. AND SEVERIN, H. C.—Anatomical and Histological Studies of the Female Reproductive Organs of the American-Saw Fly, <i>Cimbex Americana</i> , Leach.....	.25
FELT, E. P.—Some Problems in Nomenclature.....	.10
HAMMAR, A. G.—On the Nervous System of the Larva of <i>Corydalis cornuta</i> L.....	.25
BRADLEY, J. C.—A case of Gregarious Sleeping Habits among Aculeate Hymenoptera.....	.10
DAVIS, J. J.—Notes on the Life History of the Leafy Dimorph of the Boxelder Aphid, <i>Chaitophorus negundinis</i> Thos.....	.10
HAMBLETON, J. C.—The Genus <i>Corizus</i> , with a Review of the North and Middle American Species.....	.25
GIRAULT, A. A.—Biological Notes on Colorado Potato Beetle.....	.25
GIRAULT, A. A.—A Monographic Catalogue of the Mymarid Genus <i>Alaptus</i> ..	.25
SEVERIN, H. H. and SEVERIN, H. C.—Internal Organs of Reproduction of Male Saw-fly.....	.15
SMITH, C. P.—A Preliminary Study of the <i>Araneæ Theraphosæ</i> of California..	.75
DAVIS, J. J.—Studies on Aphididæ.....	.20
RILEY, W. A.—Muscle Attachment of Insects.....	.15
NEEDHAM, J. C.—Critical Notes on the Classification of the <i>Corduliinæ</i> (Odonata).....	.15
HOWARD, L. O.—A Key to the Species of <i>Prospaltella</i> with Table of Hosts and Descriptions of Four New Species.....	.15
HOOD, J. D.—Two New Species of <i>Idolothrips</i> .....	.10

Address

ANNALS ENTOMOLOGICAL SOCIETY OF AMERICA,  
Biological Building, State Univ., Columbus, Ohio.

# ANNALS

OF

## The Entomological Society of America

---

Volume VI

SEPTEMBER, 1913

Number 3

---

### A REVISION OF THE SPECIES IN *AGROMYZA* FALLEN, AND *CERODONTHA* RONDANI. (DIPTERA).

By J. R. MALLOCH.

Assistant, Cereal and Forage Insect Investigations, Bureau of Entomology.

The work on the two genera presented in this paper has been undertaken for the purpose of deciding the identity and distinctions of several species affecting field and forage crops, upon which considerable work has been done by the field agents of the division dealing with the insects affecting these crops. In some cases it has been found necessary to change the names of certain American species, as examination has proved that they are either synonymous with other American species or with species belonging to the European fauna. In the case of some other species it may at some future time become necessary to sink the American species as synonymous with European forms, but owing to the most unsatisfactory condition of the knowledge of the species contained in this family (*Agromyzidæ*) in Europe, it is not possible to definitely decide upon the correct names of their species from the brief descriptions available. Thus, while I suspect the distinctness of certain species in our fauna from others occurring in Europe, I consider it the safer plan, and one entailing no material disadvantages, to retain those species in our list, rather than rank them as synonyms of species which may ultimately prove to be absent from our fauna.

Generic Characters of *Agromyza*.

Head of normal size; frons broad, from one-third to a little over one-half the head width; ocelli on a slightly raised portion; the ocellar triangle, so distinct in the *Oscinidæ*, seldom traceable; orbits distinct, 3-5 pairs of orbital bristles present anterior to front ocellus; one pair of bristles on ocellar region slightly behind anterior ocellus, pointing forward and slightly divergent, vertical row consisting of two central divergent and two outer convergent bristles; postvertical bristles divergent; face nearly straight in vertical outline, or slightly concave, slightly keeled in center, or unkeeled; mouth margin not produced; antennæ of moderate size, or third joint enlarged, but never elongate or produced at apex; second joint with at least one dorsal setula; arista bare or pubescent, never plumose; cheeks linear or broadened posteriorly, sometimes one-half as high as eye, bristles confined to margin, vibrissa generally noticeably differentiated; proboscis membranous, not elongated noticeably nor geniculate; palpi normal. Mesonotum with 2-4 pairs of dorso-centrals; mesopleuræ with 1-3 long posterior bristles as well as generally a number of setulæ; one or two bristles above mid coxæ and generally numerous setulæ; propleural bristle strong; squamæ distinct. Ovipositor of female generally with base chitinized, apex seldom protruding; male hypopygium of moderate size, not incurved. Legs without preapical bristle on dorsal surface; end spurs weak. Wings with subcostal vein weak, sometimes incomplete, but generally complete and ending very near to first vein, or fused with first at near apex; costa at end of subcosta uninterrupted, or only slightly so; costal vein with very short hairs which are, with exception of two slightly more distinct at end of subcosta, of almost equal length to beyond middle of wing; cross veins near to wing base, or the outer one at, or slightly beyond, wing middle; posterior basal cell always complete though small; anal vein (sixth) distinct; costa to third vein, slightly beyond it, or to fourth. This last character is difficult to distinguish sometimes, and is not of sufficient importance to permit of the relegation of those species having costa to only third vein, to a different genus from those with costa to fourth.

Synoptic Table of Species in *Agromyza*.

1. Halteres white, or pale yellow; (*maculosa* has a black spot on outer side)...2  
Halteres black or brown, never pale yellow.....40
2. Species with the disk of scutellum entirely or partly pale yellow.....3  
Species with disk of scutellum colored as mesonotum, and never in part pale yellow.....11
3. At least the apical joint of antennæ black.....4  
Antennæ entirely yellow, or third joint only slightly infuscated.....5
4. Frons black, only the frontal lunule yellow.....1. *xanthophora* Schiner.  
Frons yellow, only the ocellar triangle black, and sometimes the posterior part of orbits darkened.....2. *longispinosa*, new species.
- ~~5. No short setulæ on disk of mesonotum between the dorso-central bristles..6~~
6. Mesonotum with the disk broadly black, only the lateral margins broadly, and the anterior and posterior margins yellow.....7  
Mesonotum with black, stripe-like marks, or disk black, the center of disk in front of scutellum yellow, owing to the abbreviation of central stripe..8
7. Third antennal joint and palpi, at apices, infuscated..2a. *variata*, new species.  
Third antennal joint and palpi entirely yellow.....7a
- 7a. Mesonotum bare except for the dorso-central bristles..3 *discalis*, new species.  
Mesonotum with discal setulæ in addition to dorso-centrals.....7b
- 7b. Smaller species, 1-1.75 mm., last section of fifth vein  $2\frac{1}{2}$  to 3 times as long as the penultimate section.....4 *pusilla* Meigen.  
Larger species, 2-2.5 mm., last section of fifth vein  $1\frac{1}{2}$  to 2 times as long as penultimate section.....5 *scutellata* Fallen.
8. Only the margins of the discal marks on mesonotum black, the center portions reddish brown.....8 *melampyga* var. *marginalis*, new variety.  
Markings on mesonotum unicolorous throughout.....9
9. Markings on mesonotum dull gray black, not glossy..6 *borealis*, new species.  
Markings on mesonotum glossy black.....10
10. Cheeks, posteriorly, about one-half the eye height; arista almost bare.  
Cheeks, posteriorly, much less than one-half the eye height; arista pubescent.....7 *flavonigra* Coquillett.  
.....8 *melampyga* Loew.
11. Costa reaching to third vein or slightly beyond.....12  
Costa reaching to fourth vein.....17
12. Frons lemon yellow; cross veins very close together.....13  
Frons reddish or black, never pale yellow.....14
13. Lateral margins of mesonotum broadly pale yellow; anterior two pairs of dorso-centrals on mesonotum much weaker than the posterior two pairs, the front pair not anterior to suture.....9. *brevicostalis* new species.  
Lateral margins of mesonotum colored as disk; anterior two pairs of dorso-centrals not much reduced in size, the front pair distinctly anterior to suture.....10 *davisi* Walton.
14. Frons black; cross veins not close together.....15  
Frons reddish; cross veins close together.....16
15. Pubescence on arista indistinct; occiput not projecting much on upper half.  
Pubescence on arista distinct; occiput distinctly projecting on upper half.  
.....11 *abbreviata* new species.  
.....12 *kincaidi* new species.
16. Slender, slightly shining, black species; mesonotum with four pairs of dorso-central bristles.....13 *parvicella* Coquillett.  
Robust, glossy black species; mesonotum with two pairs of dorso-central bristles.....14 *nitida*, new species.
17. Frons entirely yellow, or at least the center stripe mostly yellow or reddish, or the orbits yellow posteriorly.....18  
Frons entirely black or brown, never yellow on any part; frontal lunule sometimes white dusted.....27

18. Mesonotum opaque gray; center of disk between the rows of dorso-central bristles with a yellowish-brown, longitudinal vitta, which extends on to disk of scutellum; three pairs of orbital, and four pair of dorso-central bristles present.....15 *immaculata* Coquillett.  
Mesonotum shining, or, if opaque grayish there is no indication of a central brown vitta.....19
19. Antennæ entirely yellow, or third joint only darkened at insertion of arista.\*  
20  
Antennæ with at least the third joint black, or dark brown, never yellow..23
20. Head, including antennæ, clear lemon yellow, only ocellar region, orbits posteriorly, and back of head black, or brown; pleuræ and legs lemon yellow with black or brown marks; lateral margins of mesonotum brown.  
16 *citreifrons*, new species.  
Frons and face mostly, or entirely, reddish yellow; lateral margins of mesonotum pale yellow, or black and concolorous with disk of mesonotum...21
21. Five equally strong orbital bristles present; frons one-half as broad as head; orbits not differentiated from center stripe; mesonotum with four pairs of dorso-centrals.....17 *pruinosa* Coquillett.  
Four orbital bristles present; orbits differentiated from center stripe....22
22. Lateral margins of mesonotum pale yellow; wings narrow; outer cross vein before wing middle; last section of fourth vein three times as long as the two preceding sections together.....18 *indecisa*, new species.  
Lateral margins of mesonotum not pale yellow; wings broad; outer cross vein at near wing middle; last section of fourth vein twice as long as two preceding sections together.....19 *varifrons* Coquillett.
23. Lateral margins of mesonotum broadly pale yellow.....24  
Lateral margins of mesonotum narrowly, or not at all, yellow, the pale color confined almost entirely to the suture, or to the extreme upper margin of the pleuræ.....25
24. Frons with the center stripe clear yellow; orbits posteriorly, sometimes, blackened; legs black, or brown, the knees never distinctly yellow....  
20 *platyptera* Thomson.  
Frons with the center stripe more or less blackened; legs with the knees distinctly pale yellow.....21 *coquilletti*, new species
25. Palpi yellow.....22 *longipennis* Loew.  
Palpi black.....26
26. Larger species—3-3½ mm.—dull gray-black in color; apices of femora and bases of tibiæ narrowly yellow.....23 *coloradensis*, new species.  
Smaller species—1½-2 mm.—shining black in color; apical half of each femur yellow, tibiæ brownish yellow.....24 *marginata* Loew.
27. Mesonotum with four, or more, pairs of dorso-central bristles.....28  
Mesonotum with two or three pairs of dorso-central bristles.....35
28. The pair of bristles between the posterior pair of dorso-central almost of equal strength with them; basal two joints of antennæ, legs mostly, pleuræ, humeri, and abdomen reddish yellow; outer cross vein beyond wing middle.....25 *canadensis*, new species.  
The pair of bristles mentioned above much weaker than posterior dorso-centrals, or absent; much darker species; only sometimes a narrow side line on pleuræ, knee joints more or less broadly, and posterior margins of abdominal segments narrowly yellow; or entire thorax, abdomen and legs black, cross vein generally at or before wing middle or very slightly beyond it.....29
29. Third antennal joint in male enlarged, subquadrate, thickly covered with short, silky pilosity; in female the third joint is smaller and not so noticeably pilose; frontal lunule distinct, whitish pollinose; center stripe of frons brownish.....26 *laterella* Zetterstedt...  
Third antennal joint normal in size in both sexes, and not noticeably pilose..30

\*Sometimes *longipennis* has the antennæ yellowish, in which case the specimens will run down to *indecisa* when a comparison of the descriptions will be necessary.



30. Halteres pale yellow, with a black spot on outer side of knob; dorso-central bristles strong, anterior pairs almost as strong as posterior pairs; last section of fifth vein shorter than penultimate section.....  
*27 maculosa*, new species.
- Halteres without any dark spot on knob.....31
31. Outer cross vein at about the length of inner cross vein from that vein; third and fourth veins very distinctly divergent at apices.....  
*28 waltoni*, new species.
- Outer cross vein separated by a greater distance than inner cross vein from that vein; third and fourth veins slightly divergent at apices.....32
32. Small species, at most 2 mm., base of wing, including basal half of first vein, upper part of pleuræ and mesopleural vertical suture narrowly, a small patch below base of wing, squamæ, and fringe lemon yellow; general color shining black; outer cross vein below, or at very slightly beyond end of first vein.....*29 angulata* Loew.
- Species other than above in color, etc.....33
33. Larger species, 3 mm. and over, almost entirely black-brown; lower half of orbits rather closely set with hairs.....*30 setosa* Loew.
- Smaller species, about 2 mm., not so uniformly colored; lower half of orbits sparsely haired.....34
34. Rather robust species; wings broad; cheeks linear; tibiæ and tarsi yellowish.  
*31 isolata*, new species.
- More slender species; wings narrow; cheeks one-fourth as high posteriorly as height of eyes; tibiæ and tarsi barely paler than femora.....  
*32 fragariæ*, new species.
35. Species with three distinct pairs of dorso-central bristles.....36
- Species with 2 distinct parts of dorso-central bristles.....39
36. Glossy black species; base of wing, squamæ and small portion of pleuræ pale lemon yellow; frons not one-third the width of head; anterior pair of dorso-central bristles strong; arista as long as from its base to anterior ocellus; frontal lunule yellowish, distinctly white pollinose; male with apical segments of abdomen conspicuously pale yellow.....  
*33 posticata* Meigen
- Apex of abdomen in male not yellow; frontal lunule not yellow, not noticeably white pollinose.....37
37. Smaller species, less than 2 mm. in length.....38
- Larger species, over 2 mm. in length.....*36 dubitata*, new species.
38. Last section of fifth vein distinctly shorter than penultimate section.....  
*34 neptis* Loew.
- Last section of fifth vein distinctly longer than penultimate section.....  
*35 inconspicua*, new species.
39. Abdomen black, without any metallic sheen; antennæ brownish; arista distinctly pubescent.....*37 parvicornis* Loew.
- Abdomen black, with a metallic, bluish, or greenish sheen; antennæ black; arista never distinctly pubescent.....*38 viridula* Coquillett.
40. Costa to end of third vein.....41
- Costa to end of fourth vein.....43
41. Arista short, not more than three times as long as breadth of third antennal joint, distinctly pubescent; outer cross vein at its own length from inner cross vein; three pairs of dorso-central bristles on mesonotum.....  
*39 salicis*, new species.
- Arista bare; mesonotum with two pairs of dorso-centrals.....42
42. Cheeks very short, not higher posteriorly than anteriorly, and about one-sixth as high as eye; antennæ of moderate size; arista about three times as long as width of third joint.....*40 winnemanæ*, new species.
- Cheeks long, distinctly higher posteriorly than anteriorly, at highest part at least one-third as high as eye; antennæ rather small, arista about six times as long as width of third joint.....*41 simplex* Loew.

43. Male with anterior angle of cheek produced, the vibrissæ formed of a number of bristles, fasciculate, turned upward and generally ending in an acute joint; female with the mouth margin produced anteriorly, but without a fasciculus.....44  
Mouth margin not produced anteriorly in either sex; male vibrissæ normal..47
44. Large species, over 3 mm. in length; cheeks of almost equal height at anterior and posterior margins; antennæ brownish; arista shortly and distinctly swollen at base; palpi almost entirely bare...42 *vibrissata*, new species.  
Smaller species, generally less than 2.5 mm. in length; antennæ black; arista with elongate swelling; cheeks always higher anteriorly than posteriorly.....45
45. Small species, 1.5-2 mm.; frons weakly bristled; discal setulæ not carried beyond the transverse line of the posterior pair of dorso-centrals, generally ceasing distinctly in front of that point.....46  
Larger species, 2-2.5 mm.; frons strongly bristled; discal setulæ carried at least to transverse line of posterior pair of dorso-centrals generally beyond that point.....43 *affinis*, new species.
46. Very small species, barely 1.5 mm.; vibrissæ in male not very prominent; the anterior angle of cheeks in neither sex much produced.....  
44 *insularis*, new species.  
Larger species, about 2 mm.; vibrissæ in male prominent; anterior angle of cheek in both sexes very distinctly produced...45 *texana*, new species.
47. Species with four distinct pairs of dorso-central bristles on mesonotum; outer cross vein at barely beyond end of first vein; last section of fifth vein twice as long as penultimate section..46\**abnormalis*, new species.  
Species with generally only two distinct, rarely three, pairs of dorso-centrals; the outer cross vein at distinctly beyond end of first vein, and the last section of fifth never twice as long as penultimate section.....48
48. Eyes bare.....49  
Eyes with very distinct pubescence on the upper surface close to frontal orbits.....47 *virens* Loew.
49. Fore tibia with a distinct bristle on the posterior surface at about apical third.....50  
Fore tibia without any distinct bristle at that point.....51
50. Thorax blue, abdomen bronzy-black; orbits with sparse pubescence and the bristles situated at nearer to the eye margin than to the inner margin; squamæ white, fringe concolorous.....48 *carulea*, new species.  
Thorax black; abdomen bronzy; orbits thickly pubescent, the bristles situated on nearer to the inner margin than to the eye margin; squamæ grayish, margin and fringe brown.....49 *burgessi*, new species.
51. Arista with very long pubescence, much longer than basal diameter of arista.....50 *plumisetæ*, new species.  
Arista with shorter pubescence, or entirely bare.....52
52. Mesonotum with three distinct pairs of dorso-centrals; large species, 3.5-4 mm. Larva living in galls on wistaria twigs....51 *websteri*, new species.  
Mesonotum with only two distinct pairs of dorso-centrals; smaller species, not near 4 mm., generally 2.5 to 3 mm.....53
53. Squamæ grayish or brownish, margin and fringe always brown or blackish..54  
Squamæ whitish or yellowish, fringe concolorous.....47 *virens* Loew.
54. Arista distinctly pubescent, and almost as long as from its base to vertex..  
52 *longisetæ*, new species.  
Arista much shorter, less distinctly pubescent.....55
55. Large species, 2-3 mm.; outer cross vein at less than its own length from inner, inner at distinctly beyond middle of discal cell.....56  
Smaller species, distinctly less than 2 mm.....57
56. Mid tibial bristles distinct; larva in galls on lime trees..53 *tiliæ* Couden.  
Mid tibial bristles absent; larva in galls on poplar trees..54 *schineri*, Giraud.
57. Mouth margin with numerous, rather strong bristles, which form a group, though not a fasciculus, at anterior angle...55 *congregata*, new species.  
Mouth margin with the bristles as usual, the single vibrissa differentiated.  
56 *minima*, new species.

1. *Agromyza xanthophora* Schiner.

Syn: *Agromyza xanthophora* Schiner, Reise d. Novara, Vol. I, 1868, p. 291.

*Agromyza picta* Coquillett, Jour. N. Y. Ent. Soc., Vol. X, 1902, p. 188.

Female: Head black; frons opaque, orbits slightly shining, very narrow; ocellar region raised, sub-shining, distance between ocelli less than the distance from either ocellus to eye; lower orbital bristles cruciate, second pair slightly inwardly directed, the upper two pairs backwardly directed, the center pair in vertical row divergent, outer slightly convergent, post-vertical pair divergent. Frontal lunule yellow, with white pollinosity; face brown, sub-opaque, concave, unkeeled; cheeks almost linear, narrowest posteriorly, mouth margin with numerous hairs, and one strong incurved anterior vibrissa; antennæ black, third joint of moderate size, rounded, arista thin, slightly thickened at base, longer than the distance from its base to post-vertical bristle, thickly covered with pubescence, which is as long as the diameter of arista at base. Proboscis pale yellow; palpi black, slightly thickened. Thorax yellow; disk of mesonotum shining, but not glossy, with a black mark covering all but the margins anterior to the suture, which is sharply indented transversely at suture, subquadrate excised centrally on the posterior margin, does not reach to scutellum, and has a dentiform longitudinal excision in each lateral lobe posteriorly; four pairs of dorso-central bristles present, the anterior two pairs reduced in size, the anterior pair just in front of suture; all black portion of disk with short hairs, yellow portion bare, except for 5-6 scattered hairs present on the central posterior excision. Pleuræ with the upper half yellow, lower half black; squamæ yellow at base, apically black, the hairs brown; scutellum yellow, disk bare, margin with 4 bristles; postnotum black. Abdomen yellow, third and fourth segments with indications of a central and two lateral dark spots, most distinct on fourth; fifth and sixth segments glossy black; all segments with numerous black hairs which are bristle-like on posterior margins and most noticeable on fifth. Coxæ and legs entirely shining black; the mid tibia with the usual two posterior bristles. Wings slightly infuscated on anterior half; subcostal vein only indistinct at apex, costa from humeral vein to end of first vein about two-thirds as long as next costal division; second, third and fourth veins slightly divergent; outer cross vein as long as penultimate section of fourth, which is distinctly shorter than the preceding section of fourth; penultimate section of fifth slightly longer than last section. Halteres pale yellow.

Length, 3 mm.

Besides the type specimen of *picta* from Frontero, Tabasco, Mexico (C. H. T. Townsend), there is in the U. S. National Museum collection one female from Las Cruces, New Mexico, June, 1893, (T. D. A. Cockerell).

Food-plant unknown.

2. *Agromyza longispinosa*, new species.

Plate XXX, Fig. 22.

Male and Female: Head yellow, ocellar region, back of head, vertex, and third joint of antennæ black; frons opaque, very pale yellow, parallel-sided, distinctly broader than the eye; bristles as in *xanthophora*. Third joint of antennæ black, sharply contrasting with the pale yellow basal joints, regularly rounded and of moderate size; arista black-brown, swelling at base of terminal section elongate, almost as long as length of third antennal joint, pubescence very short, pale; face almost perpendicular, mouth margin not produced, cheeks distinctly higher posteriorly than anteriorly, at highest part about one-third as high as greatest eye-height, the row of bristles on mouth margin not very strong, black, the vibrissa of moderate strength; proboscis and palpi yellow; the latter slightly the darker, and weakly bristled. Mesonotum yellow, with opaque black-gray mark somewhat similar in outline to that of *xanthophora* but reaching more nearly to scutellum and more elongate owing to the species being less robust than *xanthophora*; the male shows some indication of a pale, linear stripe carried forward from the central posterior excision at either anterior angle, which may in some cases be so distinct as to cause the disk to present a trivittate appearance. Four pairs of very long dorso-central bristles present, the anterior two pairs but little reduced, the anterior pair distinctly anterior to the suture, and the second pair but little posterior to it; between the dorso-centrals there are two slightly irregular rows of setulæ, which are exceptionally long for this genus, and which are carried back as far as the prescutellar pair of dorso-centrals; humeri yellow, with a black spot; pleuræ yellow with a brownish spot above and slightly behind fore coxæ, another large one covering the space between the fore and mid coxæ, and another one between the mid and hind coxæ, squamæ with narrow black border, and brown fringe; scutellum yellow, bare on disk, the four marginal bristles very long; postnotum glossy black. Abdomen yellow, with apical segments darkened or with bases of all segments brownish; base of ovipositor in female glossy black; hypopygium in male glossy brownish black, of moderate size; all segments with black hairs much as in *xanthophora*. Legs yellow, tarsi brownish. Wings clear, veins 2-3 divergent, 3-4 almost parallel on last fourth; second portion of costa about two and one-half times as long as first; outer cross vein a little shorter than section of fourth vein anterior to it; first and second sections of fourth vein subequal; penultimate section of fifth vein distinctly shorter than ultimate.

Halteres yellow. Length, 1.5 mm.

Type—Cat. No. 15558, U. S. N. M.

Locality: Male: Bear Lake, British Columbia, July 20, 1903, (R. P. Currie).

Paratypes: Female—Kaslo, British Columbia, July 18, 1903, (R. P. Currie); female, same locality, July 7, 1903, (A. N. Caudell), and one one male ex. collection, Wm. Brodie, without locality, but presumably Canadian.

Food-plant unknown.

2a. *Agromyza variata*, new species.

Plate XXIX, Fig. 14.

Female: Frons lemon yellow, slightly over one-third the width of head; ocellar region black; orbits darkened on outer edge on upper half; five orbital bristles present; the anterior three closely placed and decreasing much in size to front one, which is very weak; an irregular row of weak hairs on orbits, laterally, beyond the bristles; antennæ of moderate size; yellow, third joint infuscated on apical half; arista brown, base swollen, pubescence very short; length of arista equal to a little more than twice the length of antenna; face and cheeks pale yellow; height of cheek posteriorly distinctly higher than anteriorly, at highest point less than one-fourth the height of eye, marginal bristles of moderate length, the vibrissa differentiated; proboscis yellow; palpi yellow, blackened and slightly dilated apically, occiput not visible on upper half. Mesonotum glossy black on disk, lateral margins and a large patch on center of posterior margin, which is rounded in front, pale lemon yellow; four pairs of dorso-centrals present, the disk except on the yellow parts covered with short black setulæ; pleuræ shining black, yellow along sutures and below wing base; squamæ yellow, darkened on margins, fringe brown; scutellum pale yellow on disk, a black spot on each side at base. Abdomen glossy black, posterior margins of segments narrowly yellow. Legs yellow, bases of coxæ, tibiæ except bases, and tarsi black; no bristles on posterior surface of mid tibia. Wings clear; inner cross vein at below end of first vein and at middle of discal cell; last section of fifth vein twice as long as penultimate section.

Halteres yellow.

Length, 1.5 mm.

Type: In collection C. W. Johnson.

Locality: Calais, Maine.

Food-plant unknown.

3. *Agromyza discalis*, new species.

Plate XXX, Fig. 21.

Female: Frons yellow, opaque, almost parallel-sided, except at near posterior margin, where the sides very abruptly diverge, in breadth it occupies less than one-third the width of head; orbits very narrow; four orbital bristles present; nearer to eye margin on orbit is an irregular row of very short hairs; ocellar region and back of head black; antennæ clear yellow, of less than average size; second joint with short dorsal bristle; third joint small, not longer than broad, rounded; arista black, yellowish for a short space at just beyond the rather distinct basal swelling; pubescence indistinguishable; length of arista equal to from its base to second uppermost orbital bristle, face yellow, perpendicular; cheeks yellow, twice as high at posterior margin as at anterior, and at highest part rather more than one-third as high as eye; marginal bristles weak; vibrissa moderately strong; proboscis brownish yellow;

palpi pale yellow, of normal size, bare. Mesonotum shining black on disk, finely granulose; lateral margins broadly pale yellow; humeri brown; four pairs of dorso-central bristles present, the posterior pair more widely separated and stronger than the others; in addition there is in the type an additional pair of bristles, slightly anterior to the front pair, which may be abnormal; no setulæ present between dorso-centrals on any part of disk; pleuræ glossy black, sutures narrowly yellow; squamæ pale yellow, fringe concolorous; scutellum pale yellow on disk, broadly black on sides; normal bristles four, but the type has an adventitious bristle close to base of posterior one on left side; post-notum glossy black. Abdomen glossy black; a narrow posterior marginal band on all segments, and a narrow longitudinal dorsal line on last three segments yellow; base of ovipositor glossy black; all segments with dorsal hairs, those on apex of sixth segment bristle-like. Legs yellow; blackened more or less on mid and hind coxæ; bases of femora; apices of tibiæ, and all tarsi; mid tibia without posterior bristles. Wings clear; first costal division one-half as long as second; subcostal vein distinct, outer cross vein at slightly before the end of first vein, and at about its own length from inner cross vein; last section of fifth vein four times as long as penultimate section; veins 2-3-4 gradually divergent on their last sections, the cells enclosed by these veins of equal width at below apex of second vein. Halteres yellow.

Length, 1.5 mm. -

Type: Cat. No. 15559, U. S. N. M.

Locality: Adamana, Arizona, May 7, 1903 (H. S. Barber) one female.

This species is so evidently distinct from those of the *pusilla* group that I consider it safe to describe it from a single specimen.

Food-plant unknown.

#### 4. *Agromyza pusilla* Meigen.

Syn: *Agromyza pusilla* Meigen, Syst. Besch., Vol. 6, 1830, p. 185, species 60.

*Agromyza punila* Meigen, l. c. p. 185, species 62.

*Agromyza strigata* Meigen, l. c. p. 186, species 63.

*Agromyza exilis* Meigen, l. c. p. 186, species 64.

*Agromyza orbona* Meigen, l. c. p. 186, species 65.

*Agromyza pusio* Meigen, l. c. p. 187, species 66.

*Agromyza puella* Meigen, l. c. p. 187, species 67.

*Agromyza amoena* Meigen, l. c. p. 187, species 68.

(?) *Agromyza blanda* Meigen, l. c. p. 188, species 69.

(?) *Phytomyza diminuta* Walker, Trans. Ent. Soc. Lond., n. ser. 4, 1857, p. 232.

*Oscinis trifolii* Burgess, Dept. Agric. Rept. 1879, p. 201.

*Oscinis brassicæ* Riley, Dept. Agric. Rept. 1884, p. 322.

The above synonymy is I am confident correct, as an examination of a large number of specimens from widely separated localities, including Europe, and many states in the Union, reared from different food plants proves that all the

minor differences used by Meigen for the separation of his species may be found in the same species. *Agromyza blanda* Meigen may be a different species as also may *A. annulipes* Meigen, species 61 of the series quoted in synonymy, but they may only be color varieties. The number of examples in existence representing Meigen's types of this group are as follows: *pusilla*, 1, (Paris); *annulipes*, 1, (Paris); *pumila*, 3, (Vienna); *exilis*, 1, (Paris); *pusio*, 1, (Paris); 2, (Vienna); *orbana*, 1, (Vienna); *puella*, 1 defective specimen, (Vienna); *amoena*, 1, (Paris); *blanda*, 1, (Paris).

Male and Female: Black, shining. Marked in most variable degree with yellow. Frons except ocellar region, and sometimes a narrow side stripe posteriorly, yellow; remainder of head parts except behind vertex, yellow. Mesonotum with a more or less broad yellow margin, which never extends distinctly round the anterior nor posterior margin; four pairs of dorso-central bristles present as well as numerous short hairs on disk; humeri with a black spot. Pleuræ with sometimes spots much as in *xanthophora* and at other times almost entirely black, with the sutures and upper margin yellow; scutellum entirely yellow, or yellow with black basal side spots, which in some cases extend almost round the entire margin and on to the disk; postnotum black. Abdomen yellowish with dark brownish bases to segments, black with pale apices to segments, or entirely shining black with the apical segment whitish, or yellowish, at apex. Legs almost entirely yellow, the tarsi only brownish, to legs almost entirely black with knee joints yellow, the femora generally less intensely black than other parts of legs. Mid tibia without distinct posterior bristles. Wings clear; second division of costa about two and one-half times as long as first section, third and fourth veins divergent at extremities; outer cross vein as long as or slightly shorter than the section of fourth anterior to it, basal two sections of fourth subequal or the second slightly the shorter; last section of fifth vein about three times as long as preceding section.

Halteres yellow.

Length, 1-1.75 mm.

This is a most variable species in color and is very widely distributed. The following is a list of states from which it is represented in the material I have examined. (A full list of American localities, with list of food-plants will appear in the economic bulletin, now ready for the press, dealing with this species).

Massachusetts, Connecticut, District of Columbia, Arizona, Wyoming, Texas, Colorado, California, Utah, Kansas, New Mexico, Indiana, Idaho, Florida and Virginia. It is probable that this species occurs all over the United States.

5. *Agromyza scutellata* Fallen.

Syn: *Agromyza scutellata* Fallen Dipt. Stic. *Agromyza*. 1823. 7. 3.

*Agromyza flaveola* var. Fallen, l. c. 6, 11.

*Agromyza pictella* Thomson, Fregat. Eugene. Resa, Dipt. 1851, 53, p. 609.

I have compared examples of the European species with those in collection representing *pictella* and am convinced they are identical. I have some slight doubts as to its specific distinctness, from the foregoing species, but consider it justifiable to retain it as separate species until I know something of the life history of *scutellata*, which has not been bred in this country.

Male and female: Similar in coloration to *pusilla* Meigen, except that the femora are generally the most intensely black portions of the legs and in no examples that I have seen is there any appearance of their being inclined to yellow, especially at base. In size this species is also larger and the wing neurotation is different. Otherwise, in bristling, etc., the species are identical.

The only American examples I have seen of *scutellata* are five from mountains near Claremont, California (C. F. Baker) and one from Williams, Arizona (H. S. Barber).

6. *Agromyza borealis* new species.

Plate XXIX, Fig. 10, Plate XXX, Fig. 23.

Female: This species is very close to *longispinosa*, but differs in being more robust, in having the frons reddish yellow, instead of pale yellow; the antennæ are reddish yellow; the arista is black, tapering from base to near middle, bare, and distinctly shorter than from its base to vertex; cheeks more than one-half the eye-height; marginal mouth bristles numerous, vibrissæ hardly differentiated. Mesonotum with the marks dull gray black; the posterior lateral stripes narrow, linear, distinctly separated from the inner lateral lobe; the central excision carried forward at its angles but not sufficiently to separate the inner lateral stripes from the central one on their whole length; four pairs of dorso-central bristles present, the anterior two pairs about two-thirds as large as the posterior pairs; the thorax is distinctly broader than in *longispinosa*, being almost subquadrate, in *longispinosa* it is at least one-third longer than broad; the small bristles between the dorso-centrals are at least four-rowed in *borealis*. The pleuræ and scutellum are bristled and colored as in *longispinosa*, the scutellum having two distinct dark lateral basal spots. Abdomen yellow, basal three segments brownish, next two with a brownish spot on each side, sixth with a central black spot; base of ovipositor glossy black, longer than sixth segment, which is not elongated, bristles as in *melampyga*. Legs yellow, tarsi slightly browned; mid tibiæ as in *longispinosa*, without the posterior bristles. Wings grayish, veins yellowish, except third which



is brown; outer cross vein more than its own length from inner cross vein, first and second sections of fourth vein equal; first portion of fifth two-thirds as long as last portion. Halteres yellow. Length, 1.5 mm.

Type: Cat. No. 15560, U. S. N. M.

Much as I dislike the idea of describing a new species from a single specimen, I believe that in this case I am justified in doing so, as the specimen is in good condition and presents some good characters for its separation from *longispinosa* and its allies. (Compare *arcticum* Lundbeck)

#### 7. *Agromyza flavonigra* Coquillett.

Plate XXX, Fig. 27.

Syn: *Agromyza flavonigra* Coquillett, Jour. N. Y. Ent. Soc., Vol. 10, 1902, p. 189.

Female: Head yellow, ocellar region and back of head brownish or blackish; frons distinctly, but not greatly, wider than one-third the head width; almost parallel-sided; the orbital bristles strong, black; antennæ rather small, yellow, third joint rounded in front, arista brown, yellow at base, almost bare, and falling just short of reaching to vertex; base distinctly swollen, elongate; cheeks broad, one-third higher posteriorly than anteriorly, and at former place one-half as high as eye-height; marginal bristles of moderate length, vibrissa not strong but distinctly longer than the other marginal bristles; proboscis and palpi yellow; palpi linear, with numerous short, black bristles. Mesonotum marked much as in *melampyga*, but the posterior quadrate excision in center has two linear, yellow, anterior prolongations which divide the black portion more or less distinctly into three vittæ; the posterior, longitudinal, yellow, dentiform incision of the outer lobe is also prolonged, and separates the outer portion of the posterior half of the black mark, so that it forms a separate black stripe giving the dorsum the appearance of having five vittæ. Four pairs of dorso-central bristles present, the anterior two pairs somewhat reduced in size. In other respects the thorax is much as in *melampyga*, but the fringe of the squamæ is pale and there is a lateral black spot at base on each side of scutellum. Abdomen yellow; first to fourth segments with a dorsal, brown, central spot, fifth with a pair of close placed spots on center of disk, sixth with a pair at near base which are wider placed than those on fourth, and another larger pair more widely placed at about middle; sixth segment about four times as long as fifth; base of ovipositor glossy black, conical, as long as sixth segment; all segments with numerous black hairs, those on apices of last two segments bristle-like. Legs yellow, brown on base of fore coxæ, bases and apices of all femora, as well as the entire tibiæ and tarsi of all legs. Wings much as in *melampyga*, but the inner cross vein is rather before the end of first vein, the second portion of fourth vein is shorter than first, the outer cross vein rather oblique, and the first section of fifth is shorter than in *melampyga*, being only two-thirds as long as last section. Length, 3 mm.

Locality—Beulah, New Mexico, (T. D. Cockerell). Re-described from type specimens. Food-plant unknown.

8. *Agromyza melampyga* Loew.

Plate XXX, Fig. 20; Plate XXXI, Fig. 31.

Syn: *Agromyza melampyga* Loew, Dipt. Amer. Sept. Indig. Cent. 8, 1869.*Agromyza sorosis* Williston, Trans. Ent. Soc. London, 1896, p. 429.*Agromyza flaviventris* Johnson, Can. Ent. Vol. 34, 1902, p. 242.

Male and Female: Head yellow, only black behind and on ocellar region; frons about one-third the width of head, almost parallel-sided, except at just anterior to vertex, where the eyes round off and the frons becomes rather abruptly wider; bristling normal; cheeks narrow, distinctly higher posteriorly, marginal bristles weak, anterior vibrissa incurved, of moderate size; antennæ rather below the average size, third joint rounded, arista brown, tapering, distinctly but shortly pubescent, slightly longer than the length of from its base to vertex; proboscis and palpi yellow. Thorax colored and marked as in *xanthophora*; four pairs of dorso-central bristles present; the anterior two pairs much reduced in size; other bristling as in that species; squamæ brownish from near base, the apex blackish, fringe brown. Abdomen varying from yellow to brown, with pale apices to segments; all segments with numerous black hairs. Legs generally entirely yellow, sometimes the tibiæ and tarsi are darkened somewhat; mid tibiæ with two yellow posterior bristles present. Wings clear, or slightly grayish; first costal division about one-half as long as second; second, third and fourth veins divergent on outer third; outer cross vein distinctly shorter than section of fourth vein anterior to it, or almost as long as it, first and second sections of fourth vein subequal, or the former slightly the shorter; penultimate section of fifth vein about three-fourths as long ultimate section. Halteres yellow.

Length,  $1\frac{1}{2}$ -2 mm.

This species was originally described from District of Columbia, (Osten Sacken) by Loew. Coquillett records it (Bull. 10 in ser. U. S. Dept. Agric. 1898, p. 77) as bred from leaves of a cultivated species of *Philadelphicus*, collected at Washington, D. C. during the latter part of July, 1884, and from mines in leaves of *Plantago major*, collected June 28, 1888, same locality. He states that the larva pupated within the mines. These specimens are in collections at U. S. National Museum. Besides these specimens there is one from Biscayne Bay, Florida, (Mrs. A. T. Slosson) and I have examined a series reared from Plantain, June 26, 1912, Lafayette, Indiana, (J. J. Davis).

Johnson described *flaviventris* from Niagara Falls, New York. Williston's species was from St. Vincent, West Indies. Other localities: New Jersey (Smith); White Mountains, New Hampshire (Mrs. A. T. Slosson).

***Agromyza melampyga* var. *marginalis*, new variety.**

Male and Female: This variety differs from the type in being rather smaller  $1\frac{1}{4}$  mm.; in being comparatively more strongly bristled, in having only the margins of the thoracic markings black, the remainder being yellowish, and in having the arista shorter, barely reaching to vertex in the only specimen in which it is extant.

The three specimens, two males, one female, were reared from *Paspalum*, (Oct. 2, 1912). Locality: Columbia, South Carolina, (P. Luginbill) Webster, No. 9711.

Type: Cat. No. 15561, U. S. N. M.

It is possible that this is a distinct species, but the material is too scanty to give one a basis for a definite opinion as to whether it is so, or whether the effect of a different food plant is responsible for the variation in color, etc.

**-9. *Agromyza brevicostalis*, new species.**

Plate XXVIII, Fig. 8.

Female: Frons lemon yellow; one half as broad as head and distinctly broader than long; center stripe blackened on anterior half; orbits differentiated from center stripe; four orbital bristles present; in addition to the bristles there is a row of weak hairs nearer to eye margin, which begins at opposite base of antennæ and continues to beyond upper orbital bristle; ocellar region raised, brown; back of head, and a triangular patch at lateral angle of orbits brown, or black-brown; lunule yellow; antennæ of moderate size, black brown; second joint with distinct dorsal bristle; third joint rounded in front, covered with short pilosity; arista brown; basal swelling elongate; pubescence very indistinct; length of arista equal to from its base to upper orbital bristle; face yellow, blackened on depressions below antennæ; concave in profile; keel slight; cheeks yellow, blackened anteriorly; distinctly higher posteriorly than anteriorly; height at highest part less than one-half the height of eye; occiput not projecting on upper half; proboscis yellow; palpi black, normal. Mesonotum gray black, subopaque, broadly pale yellow on lateral margins; a small patch on each side posteriorly, the pale color extending slightly on to anterior lateral angle of scutellum; four pairs of dorso-centrals present, the anterior two pairs reduced in size; no distinct dorso-centrals anterior to suture, though the 3 setulæ immediately anterior to suture in line with dorso-centrals are rather strong; discal setulæ upright, not very numerous; about 4 irregular rows between the dorso-centrals; the pair of bristles between the posterior pair of dorso-centrals distinct, and of moderate length; humeri yellow, with a dark discal mark; pleuræ black-gray, subshining; sutures and upper margin narrowly, and a patch below wing base yellow; squamæ yellow, fringe brown. Abdomen glossy black, posterior margins of all segments narrowly pale yellow; segments with numerous hairs, stronger on posterior margins; base of ovipositor glossy black, as long as preceding segment. Legs black, glossy, knees

pale yellow, fore tibia and tarsi brownish; mid tibia without posterior bristles. Wings very similar to those of *parvicella*; subcostal vein incomplete; fourth vein not so indistinct as in *parvicella*.

Halteres yellow.

Length, 2 mm.

Type: Cat. No. 15562, U. S. N. M.

Locality: Glacier National Park, Montana, (Hopkins No. 5932c.), one female.

#### 10. *Agromyza davisii* Walton.

Plate XXVIII, Fig. 7.

Syn: *Agromyza davisii* Walton, Ent. News Vol. 1912.

Female: Frons opaque, clear yellow, slightly broader than long, slightly more than one-third as wide as head, ocellar region shining black, orbits blackened posteriorly, back of head black; four pairs of orbital bristles present, the lower pair much the weakest; besides those bristles there is a row of short hairs, nearer to eye margin, almost on the whole length of orbit; antennæ above the average size, deep black, third joint subquadrate, covered with very fine short pilosity; arista gradually tapering, almost bare, as long as from its base to vertex; face brown, almost perpendicular, slightly keeled, mouth margin not produced, cheeks opaque, clear yellow, higher posteriorly than anteriorly, but at highest part only about one-fourth as high as eye-height; proboscis yellow; palpi black. Mesonotum opaque gray, four pairs of dorso-central bristles present, anterior pairs slightly weaker than the posterior two pairs; between the dorso-centrals there are on the anterior half of disk numerous setulæ which are irregularly arranged, but which represent at least four rows; anterior pair of dorso-centrals as widely placed as posterior pair; all bristles on margins very long; pleuræ subshining gray black, the upper margin narrowly yellow, as well as a patch below wing base, and the suture behind middle coxæ; squamæ pale whitish yellow, fringe concolorous; scutellum concolorous with mesonotum, four marginal bristles present; postnotum shining black. Abdomen brownish black, apices of segments yellowish, ovipositor glossy black, distinctly longer than sixth segment; all abdominal segments with scattered hairs, which are strongest on the posterior margins. Legs black, knees narrowly yellowish; mid tibia without posterior bristles. Wings with costa to slightly beyond third vein, outer cross vein below one-fourth from end of first costal division, and at about one-half its own length from inner cross vein; discal cell shorter than lower basal cell; third and fourth veins regularly divergent on their last sections; fourth vein indistinct from outer cross vein; last section of fifth vein about two times as long as penultimate section.

Halteres yellow.

Length, 2.5 mm.

Type: Cat. No. 15563, U. S. N. M.

Locality: Lafayette, Ind. (J. J. Davis).

A single specimen of this species stood in the U. S. National Museum collection as *Napomyza lateralis* Fallen. Locality: Missouri, reared from *R. abortivus*.

Food-plant: *Ranunculus abortivus*.

11. ***Agromyza abbreviata***, new species.

Plate XXXI, Fig. 32.

Male: Frons black; center stripe opaque, brownish in center; orbits glossy at base of bristles; five orbital bristles present, the bristles situated on near to inner margin of orbits; beyond them is an irregular row of hairs; ocellar region and ocellar triangle glossy, the latter rather distinctly defined for this group; antennæ as in *kincaidi*, but pubescence on arista much shorter; face subshining black, slightly concave in profile, the keel slight; cheeks opaque brown, rather long, distinctly higher at posterior margin than at anterior, at highest part a little more than one-fourth as high as eye; marginal bristles weak, in a double row, and rather numerous; the vibrissa weakly differentiated; eye comparatively larger than in *kincaidi* the occiput less projecting; proboscis yellow; palpi black, normal. Mesonotum shining black; the surface hairs numerous, and rather long; three distinct pairs of dorso-centrals present, the anterior pair reduced, and with a pair of large setulæ anterior to them; the pair of bristles between the posterior pair of dorso-centrals distinct, about half as large as the dorso-central pair; pleuræ glossy black, yellowish below wing base; squamæ yellowish white, fringe white; scutellum and postnotum glossy black. Abdomen concolorous with thorax; all segments with numerous surface hairs; hypopygium of normal size, glossy black. Legs piceous; knees yellowish, femora black; mid tibia with posterior bristles distinct. Wings clearer and comparatively broader than in *kincaidi*. Halteres yellow, knob white.

Length, 3.5 mm.

Type: Cat. No. 15564, U. S. N. M.

Locality: Las Vegas, Hot Springs, New Mexico, (H. S. Barber). One male.

12. ***Agromyza kincaidi***, new species.

Plate XXIX, Fig. 12.

Female: Entirely black, except the halteres and squamæ, which are white, distinctly shining. Frons shining but not glossy, center stripe opaque, breadth of frons slightly more than one-half of the head width, slightly divergent posteriorly, orbital bristles on near inner margin of orbits, the upper one distinctly lower than anterior ocellus, the others close together and decreasing in size as they advance towards antennæ, besides the strong bristles there are smaller hairs arranged in a row nearer to eye margin on the entire length of orbit; frons in profile slightly projecting in front; face concave, with a slight central longitudinal keel, the upper mouth margin slightly protruding; cheeks brownish, posteriorly almost one-half as high as eye-height, anteriorly less than one-half as high as posterior height; mouth margin

with a double row of bristles, the upper of which are directed forward and slightly upward, and continue to lowest level of eyes anteriorly, vibrissa stronger than other bristles, incurved, situated lower than anterior bristles on ridge above; antennæ rather small, second joint with short bristles in addition to the dorsal one, and some on under side, third joint rounded except on dorsal surface at apex, where it is truncate; arista but little swollen at base, thickly but shortly pubescent, and shorter than from its base to anterior ocellus; proboscis brownish; palpi black, of moderate size, normal in shape, rather distinctly bristled. Mesonotum with three pairs of dorso-central bristles, and one or two long hairs anterior to the third pair; in addition to these the disk is covered with numerous short hairs. (The large pins used for transfixing the two specimens have practically destroyed the thorax and make it very nearly impossible to judge the nature of the chætotaxy, and it may be that in some cases the species has four instead of three pairs of dorso-centrals). Scutellum four bristled, disk bare; squamæ whitish, fringe pale. Abdomen glossy black, all segments with numerous hairs, those on apex of sixth segment bristle-like, base of ovipositor glossy black, longer than fifth segment. Legs entirely black, the mid tibiæ with the pair of posterior bristles present. Wings grayish, veins brown, costa carried indistinctly beyond third vein, but falling much short of fourth; inner cross vein at end of first vein, outer cross vein at slightly beyond center of wing, and at nearly twice its own length from inner cross vein; second section of fourth vein shorter than first, and rather more than one-fourth as long as last section; last section of fifth three-fifths as long as the preceding section.

Halteres white.

Length, 3 mm.

Type: Cat. No. 15565, U. S. N. M.

Locality: Juneau, Alaska, July 25, 1899, (Kincaid).

The paratype which is in rather poor condition differs slightly from the type in neuration, having the outer sections of the veins comparatively longer than in the type.

The species is named in honor of Prof. Trevor Kincaid, who collected it.

This is the species recorded by Coquillett as *A. neptis* Loew, (Proc. Wash. Acad. Sci. Vol. 2, 1900, p. 463), occurring in Alaska. It is very close to the species described by Schiner (Fauna Austriaca, Vol. 2, 1864, p. 303) as *nigripes* Meigen. He misidentified Meigen's species which has the costa to the fourth vein. Afterwards Rondani placed Schiner's species in *Domomyza* and retained the specific name as *nigripes* Schiner (nec Meigen). This generic division has been repudiated by various writers, and as no other valid name has been given to this species it must be renamed. (See Addenda.)

13. *Agromyza parvicella* Coquillett.

Plate XXVIII, Fig. 4; Plate XXX, Fig. 17.

Syn: *Agromyza parvicella* Coquillett, Jour. N. Y. Ent. Soc., Vol. X, 1902, p. 189.

Female: Black, slightly shining; very slender species. Frons brown, yellowish in front, almost black at vertex, occupying more than one-half the width of the head; orbits distinct, darker than frontal stripe, each orbit rather more than one-half as wide as frontal stripe, the bristles, four on each side from anterior ocellus, situated near inner margin of orbit; the upper two stronger than the lower two, post-vertical bristles divergent; frons in profile slightly projecting, face slightly concave, mouth margin not projecting, face sub-shining, black; cheeks yellowish, more than one-half as high as eye, and of almost equal breadth on their entire length, marginal bristles weak, vibrissæ long, but not strong; antennæ black, second joint with the usual dorsal bristle, which is hair-like, otherwise entirely bare, third joint subquadrate, of moderate length, falling short of mouth margin, gently rounded at apex, arista thickened at base, very short, barely one and one-third times as long as antennæ, thickly, but very shortly pubescent; proboscis yellow at apex, membranous; palpi black, slightly projecting beyond upper mouth margin; occiput swollen from slightly below upper margin of vertex. Mesonotum subshining, four pairs of dorso-central bristles present, the pair anterior to the suture, and the anterior pair behind sutures slightly smaller than the posterior pairs; two irregular rows of setulæ between the dorso-centrals; pleuræ concolorous with disk of mesonotum, but glossy on lower portion; scutellum with four marginal bristles, disk bare; squamæ brownish, fringe long, brown. Abdomen concolorous with thorax; first segment elongated, about twice as long as second, remaining segments subequal; last abdominal segment glossy black; all segments with scattered, rather long hairs, those on apex of sixth segment longest. Legs long and slender, brown, trochanters, apices of femora and bases of tibia narrowly yellowish; no bristles present on mid tibiæ. Wings brownish, costa reaching only to end of third vein, second costal division two and one-half times as long as first; subcostal vein indistinct, obsolete on apical fifth; outer cross vein slightly before end of first vein, and at about its own length from inner cross vein, second section of fourth vein one-half as long as first; section of fifth vein between cross veins about one-fifth as long as last section; fourth vein indistinct, anal cell distinct, anal vein strong, reaching nearly to wing margin. Halteres yellow.

Length, 2 mm.

Locality: St. Paul Island, Alaska, (Kincaid).

Food-plant unknown.

Redescribed from type specimen in U. S. National Museum collection. This species is rather different from most species in *Agromyza* and may be considered by some writers as belonging to some of the other families in the Acalypterate Muscidæ, but I believe it may be most clearly associated with this genus. Like the next species it belongs to the segregate

of *Agromyza* with the costa to third vein only. This character is not of such importance that it may be considered as of generic value, and I therefore am not using Rondani's generic name *Domomyza*, as species which are very dissimilar are thrown together in *Domomyza*, and thus separated from forms to which they are more closely allied in *Agromyza*.

14. *Agromyza nitida*, new species.

Plate XXVIII, Fig. 1; Plate XXX, Fig. 26.

Female: Frons reddish yellow, distinctly longer than broad; ocellar region black; vertex and orbits posteriorly blackened; upper parts of frons shining, lower and central parts opaque; five pairs of moderately strong orbital bristles present, which are of almost uniform size and situated nearer to inner margin of orbits than to eyes; face slightly keeled, brown, in profile a little concave; antennæ brownish yellow, very short, second joint almost bare, the dorsal bristle weak, third joint longer than broad, twice as long as second, regularly rounded at apex; arista brown, slightly thickened at base, almost bare, not as long as half the length of from its base to vertex; cheeks yellow, lower margin narrowly shining black, in outline lower margin rounded, height posteriorly rather less than one-third that of the vertically elongate eye, anteriorly not so high; marginal bristles very weak, vibrissa present but not strong; proboscis yellowish brown; palpi concolorous, small, not dilated, bare. Thorax rounded above; mesonotum about one-third longer than broad, glossy black, covered on the disk with short setulose hairs, two pairs of rather widely placed, post-sutural, dorso-central bristles present, the pair of strong hairs between the posterior pair absent; humeri pale yellow, margins of mesonotum brownish; pleuræ brownish-black, glossy, upper margin narrowly yellow along suture; in front of wing base also yellowish; squamæ yellowish, the margin and fringe brown; scutellum rounded, concolorous with mesonotum, four marginal bristles present. Abdomen glossy black-brown, segments with an indication of a linear, yellow, posterior margin; ovipositor glossy black, barely longer than preceding segment; all abdominal segments with scattered hairs, those on the apical segment not much longer than the others. Wings grayish; auxiliary vein complete, but indistinct; second costal division about two and one-third times as long as first; outer cross vein situated directly below end of first vein and at its own length from inner cross vein, portion of fourth vein anterior to inner cross vein slightly more than twice as long as section beyond it; third and fourth veins regularly divergent on the whole of the last section, latter much less distinct than the longitudinal veins anterior to it; penultimate section of fifth vein one-third as long as ultimate section; costa reaching slightly beyond end of third vein. Halteres with yellow stalk and white knob.

Length, 1.5 mm.

Type: Cat. No. 15566, U. S. N. M.

Locality: Cabin John Bridge, Maryland, April 28, 1912, (Knab and Malloch). Food-plant unknown.



15. *Agromyza immaculata* Coquillett.

Plate XXVIII, Fig. 3.

Syn: *Odinia immaculata* Coquillett, Jour. N. Y. Ent. Soc., Vol. X, 1902, p. 185.

Female: Frons yellow, or reddish yellow, almost parallel-sided, in breadth distinctly, but not greatly, more than one-third the head width; ocellar region black; orbits whitish; entire frons opaque; orbital bristles strong, only three pairs anterior to lower ocellus; the lower pair of which are incurved; face and cheeks pale yellow, the former almost perpendicular and with indistinct keel, the latter distinctly higher posteriorly than anteriorly, at middle less than one-third as high as eye height; marginal mouth bristles distinct, vibrissa not much longer than other bristles; antennæ yellow, brownish on upper and outer surfaces, dorsal bristle on second joint distinct, but no other noticeable bristles present; third joint of moderate size, more than twice as long as second, regularly rounded at apex, distinctly longer than broad; arista brown, with almost the basal third swollen, lanceolate, bare, in length as long as from its base to vertex; proboscis and palpi yellow, the latter with 2-3 weak hairs at apex. Mesonotum opaque gray, the space between the dorso-central bristles opaque, yellowish, with the appearance of pollinosity; four pairs of strong dorso-centrals present, which are in parallel rows, and but little weaker anteriorly, two rows of bristles between dorso-centrals, which are regular, equally spaced from dorso-centrals and from each other, and are not continued beyond middle of disk; besides the other normal bristles there are only 3-4 small setulæ laterally beyond the dorso-centrals; humeri yellow, with a black spot, lateral margins of mesonotum yellow; pleuræ yellow, a longitudinal, elongate spot on middle from propleuræ over mesopleuræ, a large triangular spot between fore and mid coxæ, a spot above hind coxæ, and a less distinct one below wing base; squamæ brownish, fringe brown; scutellum concolorous with disk of mesonotum, the yellow central stripe more distinct and, narrowly, much paler, with more the appearance of ground than surface color, in shape the scutellum is subtriangular, flattened on surface; four marginal bristles present; postnotum anteriorly yellow, posteriorly shining black. Abdomen brownish with the posterior margins of basal four segments narrowly, and apex of sixth broadly yellow, or the sixth entirely yellow and the others broadly yellow at apices; ovipositor glossy brown, shorter than sixth segment; all segments with numerous hair-like bristles. Legs yellow, marked with brown on base of fore coxæ, upper surface and base of all femora; tibiæ and tarsi more or less brownish tinged; mid tibiæ without the posterior bristles. Wings grayish on anterior half; subcostal vein indistinct; first costal division one-third as long as second; outer cross vein distinctly beyond end of first vein, and at about twice its own length from inner cross vein, first division of fourth vein shorter than second, first section of fifth vein about three-fourths as long as last section; third and fourth veins subparallel, only distinctly divergent at extreme apices. Halteres pale yellow.

Length, 2 mm.

Type: Cat. No. 6649, U. S. N. M.

Type Locality: Mt. Washington, New Hampshire, (Mrs. A. T. Slosson).

Besides the type there are specimens in collection from the following locations: Two specimens, Santa Fe, New Mexico, (May), (H. S. Barber), one specimen St. Louis, Missouri, April 30, 1904 (W. V. Warner); and one specimen, Kaslo, British Columbia, July 17, 1903, (R. P. Currie).

Food-plant unknown.

The type specimen has the yellow thoracic markings on disk and scutellum rather indistinct, but in other respects is similar. It is a true *Agromyza* and has very little in common with *Odinia ornata* Zetterstedt, which is represented in the U. S. N. M. collection by one specimen from Dauphin county, Pennsylvania.

#### 16. *Agromyza citreifrons*, new species.

Male and Female: Frons opaque, lemon yellow, distinctly longer than broad, one-half as wide as head, parallel-sided; orbits more or less blackened or browned, especially posteriorly; three pairs of long, fine, orbital bristles anterior to front ocellus, the upper distinctly in front of anterior ocellus, anterior to lower bristle there is a weak hair, otherwise the orbits are bare; ocellar region and back of head black; antennæ of moderate size, clear lemon yellow; second joint bare except for the weak dorsal bristle; third joint rounded, about three times as long as second; arista concolorous with antennæ on the swollen base, brown on remainder, almost bare, barely as long as from its base to anterior ocellus; face yellow, slightly retreating in profile; cheeks concolorous, higher posteriorly than anteriorly, at highest part over one-third the height of eye; eye slightly longer than high; marginal mouth bristles not numerous (4-5) but rather strong, the vibrissa hardly differentiated; proboscis and palpi clear lemon yellow. Mesonotum opaque, brown-black; lateral margins and humeri brownish yellow; four pairs of dorso-central bristles, arranged in parallel rows, anteriorly reduced in length; setulæ between dorso-centrals irregularly arranged in 3-4 rows, extending to posterior margin; pleuræ lemon yellow, a large brown or blackish triangular spot between the fore and mid coxæ, another smaller one over hind coxæ and an indistinct longitudinal mark sometimes present on mesopleuræ on middle; squamæ brownish, fringe brown; scutellum brown, with four marginal bristles; postnotum black. Abdomen shining brown, or blackish, lateral margins yellow in female, ovipositor of female glossy brown-black, as long as preceding segment of abdomen; hypopygium of male brownish, organs knob-like, of moderate size; all segments with numerous black hairs, which are noticeably longer on lateral margins and apices of last two segments. Legs yellow, tarsi browned; mid tibia without posterior bristles. Wings clear or slightly

browened; first costal division half as long as second, veins 2-3-4 regularly divergent on last sections, outer cross vein at beyond end of first vein, and at a little more than its own length from inner cross vein or at its own length from it, second section of fourth vein distinctly shorter than first; last section of fifth vein about twice as long as penultimate.

Halteres lemon yellow.

Length, 1-1.5 mm.

Type: Cat. No. 15567, U. S. N. M.

Type locality: Eureka, California, (H. S. Barber). Seven specimens. I have seen one specimen in C. W. Johnson's collection from Princeton, Maine, July 12, 1908.

Food-plant unknown.

#### 17. *Agromyza pruinosa* Coquillett.

Syn: *Agromyza pruinosa* Coquillett, Jour. N. Y. Ent. Soc., Vol. X, 1902, p. 189.

Male: Frons opaque, center stripe reddish, merging into brown on margins and posteriorly, orbits not distinctly differentiated, and, with outer margin of center stripe, blackish; breadth of frons one-half as wide as head; five orbital bristles present, the lower four pairs incurved, the upper one backwardly directed, no distinct orbital hairs present; vertical row and postvertical pair strong; lunule not differentiated from center stripe; face and cheeks reddish yellow, the former concave in profile, keel distinct, and brownish; eye orbits carried back over cheeks, blackish, cheeks and orbits at posterior angle of eye as high as eye, marginal bristles on mouth opening 4-5 in number, strong, upwardly directed, vibrissa hardly stronger, though distinct; proboscis and palpi reddish yellow. Mesonotum grayish black, opaque, elongate, about one-half longer than broad; four pairs of dorso-centrals present, about three irregular rows of setulae between the dorso-centrals; the pair of bristles between posterior pair of dorso-centrals distinct; pleurae subshining, black-brown, paler below wing base; squamæ of moderate size, whitish, fringe brown. Abdomen subshining, brownish; hypopygium yellowish brown; of moderate size, all segments strongly haired. Legs strong; reddish yellow, bases of femora, apices of tibiae broadly, and entire tarsi brown; fore femora with distinct, rather long central bristles; mid tibia without any distinct posterior bristles. Wings slightly grayish; first costal division at least one-half as long as second, subcostal vein rather indistinct, complete; inner cross vein at very slightly before end of first vein, outer cross vein slightly outward bent at middle, at almost its own length from inner, and at very little beyond wing middle; veins 2-3-4 distinctly divergent on the outer section; second and third sections of fourth vein together half as long as last section; last two sections of fifth vein subequal. Halteres whitish yellow.

Length, 2.5 mm.

Redescribed from type (Cat. No. 6659, U. S. N. M.).

Locality: Colorado, (H. K. Morrison).

Food-plant unknown.

18. *Agromyza indecisa*, new species.

Female: Frons elongate, fully one and one-third times as long as broad, two-fifths as wide as head; orbits barely darker than central stripe; four equally strong orbital bristles anterior to front ocellus, the upper only slightly lower than anterior ocellus; besides these strong bristles there are several weak hairs situated nearer to eye margin opposite spaces between the bristles; antennæ reddish yellow, shaped and bristled as in *citrefrons*; arista entirely brown-black, distinctly swollen at base, almost bare, not reaching to anterior ocellus; face pale yellow, not produced at mouth margin, slightly keeled; cheeks distinctly higher posteriorly than anteriorly, at highest part one-third as high as eye; bristles much as in *citrefrons*; eye as high as long; proboscis and palpi yellow. Mesonotum black, subshining, disk slightly gray pollinose; lateral margins and humeri pale yellow; four pairs of dorso-central bristles present; anterior to the one in front of suture there is a small bristle which may be abnormal; other bristling as in *citrefrons*; pleuræ brown-black, shining; sutures yellow, squamæ brown; scutellum concolorous with disk of mesonotum, four bristled; postnotum shining black. Abdomen subopaque, brown-black; segments narrowly bordered posteriorly with yellow; ovipositor with base as long as sixth segment; bristles as in *citrefrons*. Legs yellowish brown; fore coxæ, with ventral surfaces and apices of femora yellow; posterior mid tibial bristles absent. Wings grayish; second costal division short of twice as long as first; subcostal vein rather distinct; outer cross vein beyond end of first vein, and at about its own length from inner cross vein; first section of fourth vein longer than second; last section of fifth twice as long as penultimate section. Halteres yellow.

Length, 1.5 mm.

Type: Cat. No. 15568, U. S. N. M.

Locality: Las Vegas, New Mexico, June, 1901, 11,000 feet level, (T. D. A. Cockerell).

Food-plant unknown.

19. *Agromyza varifrons* Coquillett.

Syn: *Agromyza varifrons* Coquillett, Jour. N. Y. Ent. Soc., Vol. X, 1902, p. 189.

Female: Frons parallel-sided, subopaque, center stripe and orbits clear reddish yellow on lower half, blackened on upper half; orbits differentiated from center stripe, very narrow, each about one-fifth as wide as center stripe; four orbital bristles present, which are slightly reduced in strength from upper to lower bristle; no hairs on orbits besides the bristles; antennæ yellow, darkened on third joint at insertion of arista; second joint with dorsal bristle and weak apical hairs; third joint rounded in front, of moderate size, not longer than broad, covered with thick, but very short, white pilosity; arista brown, short, about one and one-third times as long as antenna, and as long as from its base to between upper two orbital bristles; pubescence very short but close; face and cheeks yellow, paler than frons, the latter gradually becoming higher towards

posterior margin, at posterior margin less than one-third the eye height, bristles on margin rather weak, vibrissa well differentiated; proboscis and palpi yellow. Mesonotum glossy black, humeri brownish; two pairs of dorso-central bristles present; disk with numerous short setulæ; pleuræ glossy black, brownish below wing base, squamæ grayish, margin and fringe brown; scutellum and postnotum concolorous with disk of mesonotum. Abdomen glossy black; base of ovipositor distinctly longer than preceding abdominal segment; posterior marginal bristles on last abdominal segment strong. Legs brown, apices of femora and bases of tibiæ paler, yellowish, mid tibia without distinctly differentiated posterior bristles. Wings clear, broad; first costal division almost one-half as long as second; inner cross vein beyond end of first vein, outer cross vein at below middle of wing, taking its upper end as below middle of costa, and at less than its own length from inner cross vein; second section of fourth vein less than one-half as long as first, first and second sections of this vein together half as long as last section; veins 2-3-4 divergent, fourth vein at below apex of wing; last two sections of fifth vein subequal. Halteres pale yellow. Length, 2 mm.

Redescribed from type. (Cat. No. 6658, U. S. N. M.).

Locality: Washington, District of Columbia, (collection Coquillett). A male in C. W. Johnson's collection from Pottstown, Pennsylvania, differs from the type in having the frons and antennæ paler lemon yellow, the arista slightly longer, and the cheeks distinctly over one-third the height of eye. In other respects similar to the female.

Food-plant unknown.

## 20. *Agromyza platyptera* Thomson.

Syn: *Agromyza platyptera* Thomson, Eugene Resa, 1851-1853, p. 608.

*Agromyza coronata* Loew, Dipt. Amer. Sept. Indig., Cent. 8, 1869, p. 162.

*Agromyza jucunda* v. d. Wulp., Tijdschr. v. Entom. Vol. X, 1866, p. 161.

*Oscinis malvæ* Burgess, Dept. Agric. Rept. 1879, p. 202.

*Agromyza lateralis* Williston, Trans. Ent. Soc. Lond. 1896, p. 428.

Male and Female: Frons opaque, lemon yellow; orbits sometimes posteriorly blackened, four pairs of orbital bristles anterior to front ocellus; frons generally over one and one-half times as long as broad, and one-third of the head with; ocellar region and back of head black; face slightly concave in profile, yellow, slightly keeled in center; cheeks yellow, rather short, higher posteriorly than anteriorly, at highest part short of one-third the height of eye; eye higher than long; bristles on mouth margin moderately strong, numerous, upper ones upturned, vibrissæ stronger than other bristles; proboscis yellow; palpi black, normal in shape; antennæ black; dorsal bristle on second joint weak, third joint short, regularly rounded, higher than long, arista brown-black, swollen at base, very shortly pubescent; not as long as from its base to vertex. Mesonotum shining black; lateral margins, including humeri, broadly pale yellow; two pairs of dorso-centrals present, some-

times a weaker anterior pair visible also; surface of disk with numerous irregularly arranged setulæ; pleuræ glossy black, with upper margin rather broadly and sutures narrowly yellow; scutellum and postnotum concolorous with disk of mesonotum, the former with four bristles. Abdomen shining, brownish-black, segments sometimes narrowly yellow on posterior margins; last segment elongate; all segments with black hairs. Legs glossy black, only in immature specimens paler on knees; mid tibiæ with the posterior bristles indistinct. Wings clear; first costal division one-half as long as second; subcostal vein indistinct at apex; outer cross vein at very slightly beyond end of first vein, and at, or nearly at, its own length from inner cross vein, second section of fourth vein about as long as first vein or short of it; veins 2-3-4 divergent, last section of fifth vein about twice as long as penultimate section. Halteres yellow, knob paler.

Length, 2-3 mm.

Originally described from California. Loew's specimens (*coronata*) were from Cuba and Pennsylvania. Van der Wulp obtained his specimens (*jucunda*) from Wisconsin. Burgess described his specimens (*malva*) reared from *Malva rotundifolia* from District of Columbia; while Williston's specimens, (*lateralis*), came from St. Vincent, West Indies.

I have before me specimens from the following localities: Algonquin, Illinois, (collection Coquillett); Tempe, Arizona, (V. L. Wildermuth), Webster's No. 7286; White Mountains, New Hampshire, (Morrison ?); Los Angeles, California; (Coquillett); District of Columbia, from *Solidago*, (no collector's name); Cabin John, Maryland, (Knab and Malloch); San Rafael, Vera Cruz, (C. H. T. Townsend); Baracoa, Cuba, (Busck); Mayaguez, Porto Rico, (Busck); and 3 specimens without locality, one from aster, one from sunflowers and one from verbena.

One of the two specimens from Cabin John, Maryland (April 28, 1912) is much larger than the average, nearly 4 mm. and has the orbital bristles five in number, as well as the anterior hairs in line with the dorso-centrals much stronger than normal, so that there may be said to be four pairs of dorso-centrals. I consider, however, that it is merely an abnormal specimen and not a distinct species, because in almost every other respect it agrees with the typical specimens.

I have arrived at the decision as to the synonymy of this species from a careful persual of the various descriptions, and consider that it is correct.

I have examined specimens from C. W. Johnson's collection from the following localities: Wollaston, Woods Holl,

Dedham, Auburndale, Fall River and Chester, Massachusetts; Durham, New Hampshire, Winnipauk, Connecticut; Kingston, Rhode Island, and Riverton, New Jersey, which agree well with the description given. Three specimens from same collection taken in the following localities: Chester and Blue Hills, Massachusetts, and Delaware Water Gap, Pennsylvania (Mrs. A. T. Slosson), differ in size, 3 mm., and in having an anteriorly bidentate, yellow spot, posteriorly on each side of disk, the pale color extending on to scutellum at base on each side. I consider that this is merely a color variety, due possibly to a difference in food-plant, or some other cause which could only be determined by rearing the species.

21. *Agromyza coquilletti*, new species.

Plate XXX, Fig. 28.

Male and Female: Frons lemon yellow, subshining, center stripe blackened, most distinctly on anterior margin where it meets the lunule, which is exceptionally elongated, the black color generally disappears on posterior part of center stripe; ocellar region black; orbits black on posterior angle, each orbit half as wide as center stripe at anterior ocellus, gradually broadened to anterior margins of center stripe where each orbit is almost of equal width with center stripe; four orbital bristles present, situated on middle of orbit, laterally beyond these there is a row of 5-7 short setulæ, which does not extend to upper orbital bristle; antennæ of moderate size, black, second joint brownish; third joint twice as long as second, upper margin flattened a little and apex rather acute, not regularly rounded; arista brown, thickened at base for about one-fourth the length of arista, nearly bare, and as long as from its base to anterior ocellus; face almost perpendicular, slightly produced at mouth margin, slightly keeled, yellow; cheeks yellow, posteriorly almost one-third the length of eye, anteriorly much less; marginal bristles of moderate size, vibrissa strong; proboscis yellow; palpi black. Mesonotum subshining, black, with grayish pollinosity; three pairs of distinct dorso-central bristles, the setulæ anterior to them stronger than the other discal hairs; lateral margins and humeri pale yellow; the pair of bristles between posterior dorso-centrals weak; pleuræ brown-black, shining, upper margin and central, vertical, suture narrowly yellow; squamæ and its fringe pale yellow; scutellum and postnotum black, shining; abdomen brown-black, shining; all segments narrowly margined with yellow posteriorly; hypopygium of male yellowish-brown; ovipositor of female glossy black, the base as long as last abdominal segment. Legs glossy black, knees distinctly pale yellow; posterior bristles absent from mid tibia; ventral bristles on fore femur rather long. Wings clear, basal part of veins lemon yellow; subcostal vein indistinct; outer cross vein a little before wing middle and well beyond end of first vein; second section of fourth vein longer

than first and twice as long as outer cross vein; third and fourth veins almost parallel from outer cross vein, only divergent at extreme apices; last section of fifth vein about one-fourth longer than penultimate section. Halteres yellow.

Length, 2 mm.

Type: Female. Cat. No. 15569, U. S. N. M.

Type locality: Fort Collins, Colorado, Webster's No. 6610, (C. N. Ainslie), bred from oats

Paratypes: Tower City, North Dakota, Webster's No. 3047, (G. I. Reeves), swept amongst grass; Fort Collins, Colorado, Webster's No. 6646, reared from *Hordeum jubatum*, July, 1910, (C. N. Ainslie); Buckton, Kansas, Webster's No. 5555; reared from volunteer wheat, June 11, 1909, (C. N. Ainslie); Hawkins, Summit County, Ohio (?), August 16, 1902 (no collector's name); Massachusetts (collection Coquillett). I have also examined specimens from C. W. Johnson's collection from the following localities: Fern Rock, Pennsylvania; Norwich, Vermont, Nantucket, Massachusetts and Hanover, New Hampshire.

This species is named in honor of the late D. W. Coquillett, whose work has done much to facilitate an understanding of the North American Diptera.

## 22. *Agromyza longipennis* Loew.

Syn: *Agromyza longipennis* Loew, Dipt. Amer. Sept. Indig., Cent. 8, 1869, species 90.

Female: Frons pale lemon yellow, incision above lunule slightly darkened; orbits blackened posteriorly; ocellar region black; breadth of frons equal to over one-third the width of head, in outline the sides are almost parallel or a little divergent anteriorly; four pairs of long orbital bristles present, in addition to the bristles there is an irregular row of weak hairs nearer to eye margins, which begins at base of antennæ and extends to opposite the anterior ocellus; antennæ brownish yellow, darker dorsally, of moderate size; second joint with weak hairs on apical margin, and the usual dorsal bristle of moderate length; third joint rounded, covered with thick, but short, pilosity; arista brownish, swollen at base, very thickly pubescent, the pubescence as long as basal diameter of arista, arista as long as from its base to posterior ocelli; face and cheeks clear lemon yellow, the former slightly concave, and with slight keel; cheeks about twice as high at posterior as at anterior margin, at highest part slightly less than one-third the eye height; eye distinctly higher than long, marginal mouth bristles weak but numerous, vibrissa strong. Mesonotum subshining, black; four pairs of almost equally strong dorso-central bristles present; between which are 4-5 rather irregular rows of setulæ, no distinctly differentiated bristles between posterior dorso-centrals; lateral margins of mesonotum



sometimes brownish, pleuræ brown-black, subshining; upper margin, central vertical suture, and below base of wing narrowly yellow; scutellum concolorous with mesonotum, four bristled; postnotum brown-black, shining. Abdomen shining brownish or blackish; ovipositor glossy black, base slightly longer than last abdominal segment, covered with numerous short hairs. Legs brownish; fore coxæ, apices of all femora broadly, and bases of tibiæ yellow; the basal two pairs of former are generally almost black; posterior bristles absent from mid tibiæ. Wings elongate, clear or slightly grayish; first costal division one-third as long as second; inner cross vein at just below end of first vein or very slightly beyond it; outer cross vein distinctly shorter than section of fourth vein anterior to it, first and second sections of fourth vein subequal; last two sections of fifth vein subequal. Halteres pale yellow.

Length, 2.5 to 3 mm.

Originally described from District of Columbia (Osten Sacken).

Represented in collection by two specimens from Mount Washington and Franconia, New Hampshire, (Mrs. A. T. Slosson, collection Coquillett); and two from Algonquin, Ill., (collection Coquillett). Three of the specimens were standing as *A. xanthocephala* Zetterstedt, in collection. This identification may have been given out by Coquillett, though I cannot find any published record of the name. Zetterstedt's species differs from Loew's in having the legs entirely black. *Longipennis* comes very close *capitata* Zetterstedt as understood in Britain, but I have no specimens for comparison, and as Kertész gives *capitata* as a synonym of *geniculata*, which I have from Holland, and find distinct, I consider it advisable to continue the use of Loew's name, meantime.

Food-plant unknown.

### 23. *Agromyza coloradensis*, new species.

Male and Female: Frons opaque, ochreous yellow, about one-third longer than broad, sides almost parallel; orbits at lunule not one-half as wide as center stripe at same part; five pairs of orbital bristles present, the one nearest antennæ weakest; these bristles occupy middle of orbit and laterally beyond them is an irregular row of short hairs which extends from base of antennæ to fifth orbital bristle; sides of orbits and back of head blackened; ocellar region shining black; antennæ black; basal joint and apex of second on inner surface yellow; second joint with numerous short hairs on dorsal and ventral surfaces, the dorsal bristle distinct; third joint of moderate size, slightly longer than high, regularly rounded on the upper margin or apex obtusely angled; arista black, slightly thickened at base, the pubescence thick but very short, arista in length reaching to front ocellus; face and cheeks pale yellow, the former concave and very slightly keeled in center; cheeks higher pos-

teriorly than anteriorly, at highest part about one-third as high as eye, marginal bristles distinct, 6-7, the anterior pair higher than vibrissa; vibrissa strong; proboscis yellow; palpi black, distinctly bristled. Mesonotum subopaque, gray-black, about one-third longer than broad; lateral margins with indications of brownish color, but not yellow; four pairs of long dorso-central bristles present, which are in parallel rows, the anterior pair distinctly in front of suture; four irregular rows of setulae between the dorso-centrals, which are carried to between posterior pair; no distinctly differentiated bristles between posterior dorso-centrals; pleurae marked as in *longipennis*; squamae yellow, fringe brownish; postnotum and scutellum concolorous with disk of mesonotum. Abdomen elongate, shining black, with grayish pollinosity, only the last segment with distinct, very narrow, yellow posterior margins; ovipositor glossy black, base as long as last abdominal segment, segments with numerous short hairs; hypopygium of male rounded, with two flap-like protruding, downward directed, apical organs. Legs black, shining, knees distinctly, but narrowly, pale yellow; mid tibiae without posterior bristles. Wings grayish, rather elongate, venation almost as in *longipennis*. Halteres yellow.

Length, 3.5 to 4 mm.

Type: (Male); Cat. No. 15570, U. S. N. M.

Locality: Florissant, Colorado, (7,000 feet level) June 21, 1907, (S. A. Rohwer). Five specimens, two males and three females. Taken amongst grass. There is a female from Colorado in C. W. Johnson's collection and a male in same collection from Eastport Maine.

Food-plant unknown.

#### 24. *Agromyza marginata* Loew.

Syn: *Agromyza marginata* Loew, Dipt. Amer. Sept. Indig. Cent. 8, 1869, species 91.

Male and Female: Frons pale lemon yellow, shining, center stripe opaque black, deepest in color at anterior margin above lunule; ocellar triangle distinct, black, margins narrowly yellow; orbits of nearly equal breadth on their entire length, darkened anteriorly, four orbital bristles anterior to front ocellus, these are on middle of orbits, there are no additional hairs present on any of the specimens before me; antennae brown, of rather less than normal size, dorsal bristles on second joint of moderate size; third joint rounded, barely longer than broad; arista brown, slightly swollen and tapering at base, almost bare, reaching from its base to anterior ocellus in female, slightly shorter in male; face brown, concave in profile, the lower margin, at mouth, projecting slightly, center keel indistinct; cheeks yellowish brown, short, gradually deepening from front to back, where they are less than one-fourth the height of the eye; marginal bristles distinct, vibrissa strong; eye distinctly higher than long. Mesonotum slightly longer than broad, glossy black brown; three pairs of dorso-centrals present, the anterior pair weak, disk with numerous distinct

setulæ; lateral margins and humeri brown; pleuræ glossy brown-black; upper margin and central, vertical, suture narrowly, and a patch below wing base yellow; scutellum distinctly broader than long, concolorous with disk of mesonotum; postnotum concolorous with pleuræ; squamæ yellow, margin and fringe brown. Abdomen glossy brown, or black-brown, posterior margin of last segment sometimes narrowly yellowish; last abdominal segment almost as long as the three preceding segments, ovipositor elongate, glossy black; male hypopygium knob-like, of moderate size, about one-fourth as long as preceding abdominal segment; surface hairs most numerous on the sides of second segment, and longest on apical segments. Legs yellow; basal half of each femur brown-black, apices of tibiæ and all tarsi more or less browned; posterior mid tibial bristles absent. Wings grayish; first costal division one-third as long as second, subcostal vein indistinct, but complete, inner cross vein at just below end of first vein, outer cross vein at distinctly more than its own length from inner and at wing middle; first and second sections of fourth vein subequal; penultimate section of fifth vein slightly shorter than ultimate; outer half of last sections of veins 3-4 almost parallel. Halteres clear yellow.

Length, 1.5 mm.

Originally described from District of Columbia (Osten Sacken).

Represented in collection by three specimens, two females and one male, from Beverly, Massachusetts (Burgess). These specimens bear the dates May 28, 1868; August 28, 1869; and May 24, 1874, respectively.

Food-plant unknown.

25. *Agromyza canadensis*, new species.

Plate XXX, Fig. 19.

Female: Frons opaque, brown, sides subparallel, in breadth one-third the width of head and distinctly longer than broad, orbits slightly differentiated, subshining; orbital bristles five in number, situated near to inner margin of orbits, decreasing in size from back to front; no hairs on orbits in addition to bristles; ocellar region shining, the anterior ocellus separated more widely from posterior ocelli than posterior ocelli from each other; antennæ yellowish-red, third joint brown; second joint with strong dorsal bristle, and weaker apical hairs; third joint rather elongate, one-third longer than broad, rounded at tip; arista brown, yellow, and with an elongate swelling at base, pubescence very weak, distinctly shorter than basal diameter of arista, length of arista as long as from its base to between upper two orbital bristles; face in profile perpendicular, yellow, with whitish dusting and distinct keel, a blackish line on each side of keel, cheeks linear, only slightly higher at posterior margin than anteriorly, brown, paler on margins; marginal bristles upturned, of moderate strength; vibrissa strong; the weak bristles are continued upward beyond the level of vibrissa; proboscis yellow; palpi brown, slightly spatulate, with distinct bristles.

Mesonotum shining, brown-black on disk, with gray dusting, humeri and lateral margins reddish yellow; five pairs of dorso-central bristles present, the anterior three pairs reduced in size, only the front pair anterior to suture; the pair of bristles between the posterior dorso-centrals very strong; disk with numerous setulose hairs; pleurae brown, shining, sutures and below wing base yellowish; squamae whitish yellow, fringe concolorous; scutellum and postnotum concolorous with disk of mesonotum. Abdomen reddish yellow; last segment not elongated; base of ovipositor glossy black, slightly longer than preceding abdominal segment; all segments with numerous black bristle-like hairs. Legs yellow, stout; posterior side of mid tibia with two bristles. Wings slightly grayish; costa thickened at end of first vein, first costal division (to near side of first vein) less than one-half as long as next division (from end of swollen junction of first vein with costa); upper end of outer cross vein below a point in costa beyond middle of wing; veins 2-3 distinctly, 3-4 hardly divergent; section of fourth vein beyond inner cross vein one and one-half times as long as outer cross vein, and distinctly longer than preceding section of fourth; inner cross vein below junction of first vein with costa; last section of fifth vein three-fifths as long as penultimate section; basal part of wing veins clear yellow. Halteres yellow, knob whitish.

Length 3 mm.

Type: Cat. No. 15571, U. S. N. M.

Locality: Cottage Beaulieu, Ottawa, Canada, August 14, 1906, (Germain Beaulieu), one female.

Food-plant unknown.

#### 26. *Agromyza laterella* Zetterstedt.

Syn: *Agromyza laterella* Zetterstedt, Ins. Lappon, 1838, p. 788, species 7.

*Agromyza grossicornis* Zetterstedt; Dipt. Scand. Vol. XIV, 1860, p. 6456.

*Agromyza magnicornis* Loew, Dipt. Amer. Sept. Indig., Cent. 8, 1869, species 86.

Male and Female: Frons about one-half as broad as head, center stripe opaque, brownish or blackish, with slight whitish dusting, orbits shining, four or five orbital bristles anterior to front ocellus, beyond these, laterally, is an irregular row of hairs; frontal lunule whitish dusted, very distinct; ocellar region shining black; antennae black; in male large, third joint very variable both in size and shape, either subquadrate, elongated and truncate at apex, or enlarged and rounded at apex, very thickly covered with distinct, pale pilosity; in female the third antennal joint is much smaller and rounded; arista black, inserted near base of third joint, thickened on basal third, pubescence very short and indistinct, length of arista equal to from its base to second uppermost orbital bristle; head of male slightly produced in front, the frons slightly buccate; face concave; cheeks short, distinctly higher posteriorly than anteriorly, but at highest part not one-fourth as high as eye, marginal bristles distinct; vibrissa well differentiated; proboscis yellow; palpi black, normal; occiput unprojecting on upper half. Mesonotum black, slightly shining, indistinctly gray dusted, lateral margins

brownish yellow; four pairs of dorso-centrals present; discal setulae rather strong; the pair of bristles between the posterior pair of dorso-centrals distinct, but not large; pleurae glossy black, narrowly lemon yellow along upper and medium vertical suture, and broadly below wing base; squamae almost white, fringe concolorous; scutellum and postnotum gray black. Abdomen glossy black, or black-brown, posterior margins of segments generally narrowly yellow, sometimes the base of abdomen yellow laterally; hypopygium of male small; ovipositor of female glossy black on basal portion. Legs black, or black-brown, knees distinctly pale yellow; mid tibia without distinct bristles on posterior surface, except in one specimen. Wings clear, basal part of thick veins pale yellow; subcostal vein indistinct, but complete; second costal division about  $2\frac{1}{2}$  times as long as first; inner cross vein at just before end of first vein, and at about middle of discal cell; last cell section of fifth vein subequal with penultimate section; veins 3-4 slightly divergent on their last sections. Halteres yellow.

Length 1.5-2.5 mm.

Localities of specimens examined: Algonquin, Illinois, (collection Coquillett); Franconia, New Hampshire, (Mrs. A. T. Slosson); Biscayne Bay, Florida, (Mrs. A. T. Slosson); Rosslyn, Virginia, October, 1903, (E. S. G. Titus); Beverly, Massachusetts, June 1, 1868, (Burgess); another same collector and locality, June 2, 1876; Worcester, Mass., "Gall on Iris" (no collector's name); and South Fork, British Columbia, (R. P. Currie). There are specimens in C. W. Johnson's collection from Chester and Framingham, Massachusetts.

This species has been recorded by Thomson,\* as feeding galls on blue Iris, and although there is no collector's name on the Worcester specimen mentioned above, it is very probably belongs to the lot reared by him, as Coquillett identified specimens.

This is a very variable species in color, and structure of the antennae, and one might be easily led into considering some of the forms as distinct species. I am, however, convinced from my acquaintance with the species in Britain, that there is but one species, though it probably feeds upon different food plants, as I have met with it in situations where it could not have fed upon Iris.

---

\*Psyche, Vol. XIV, 1907, p. 74.

27. *Agromyza maculosa*, new species.

Male and Female: Shining black, frontal lunule silvery white pollinose; legs with tibiae and tarsi sometimes brownish; halteres white with black spot.

Frons very slightly more than one-third the head width; center stripe opaque; orbits glossy, differentiated from center stripe; five (and occasionally six), strong orbital bristles present; frontal lunule distinct, viewed from above and behind shining silvery white; antennae with second joint brownish, dorsal bristle distinct; third joint of moderate size, rounded at apex, covered with very short, brownish pubescence; arista brown, distinctly swollen and tapering at base, pubescence short and close; length of arista equal to from its base to between upper two orbital bristles anterior to ocelli; face shining in center, subopaque on sides, in profile concave; the central keel rounded, not sharp, cheeks rather short, twice as high posteriorly as anteriorly, marginal bristles rather strong though short, slightly upcurved and continued weakly beyond vibrissa; vibrissa strong, well differentiated; proboscis brownish yellow; palpi black, of normal size and shape. Mesonotum with four pairs of strong dorso-centrals which are slightly reduced in size from posterior to anterior pairs; five or six rather irregular rows of setulae between the dorso-centrals, the pair of bristles between the posterior dorso-centrals slightly differentiated from the discal setulae; pleurae below wing base slightly yellowish; squamae of rather large size, white, fringe concolorous. Abdomen rather broad, ovate; all segments with short dorsal hairs, stronger on margins laterally and posteriorly, noticeably longer on posterior margins of last two segments; base of ovipositor barely longer than preceding segment. Legs strong, front femur with distinct ventral bristles; mid tibia with the posterior two bristles distinct. Wings with base slightly yellowish; first vein yellowish to end; subcostal vein weak; first costal division one-half as long as second; inner cross vein at below end of first vein; outer cross vein at slightly beyond middle of wing, and at its own length, or slightly more, from inner cross vein; last section of fifth vein distinctly, but not greatly shorter than penultimate section; veins 2 and 3 distinctly, 3 and 4 slightly divergent. Halteres white, outer surface of knob and most of stalk blackened.

Length, 3-4 mm.

Type: Cat. No. 15641, U. S. N. M.

Type locality: Jamaica, New York, October, 1896. Bred from chrysanthemum leaves. Paratypes from Louisville, Ky., October 27, 1898; 6 specimens bred from chrysanthemum leaves No. 4064; Lafayette, Ind., October 11, 1901, (H. B. Dorner), 5 specimens bred from leaves of aster; Jamaica, New York, 2 specimens from same lot as type; and one specimen without data from Georgia. One specimen in C. W. Johnson's collection from Bermuda, West Indies.

28. *Agromyza waltoni*, new species.

Plate XXVIII, Fig. 6; Plate XXXI, Fig. 36.

Female: Frons black, center stripe opaque, orbits subshining, glossy at base of bristles; breadth of frons slightly more than one-half the head width, and almost subquadrate; orbits slightly differentiated from center stripe, each at broadest part about one-fourth the breadth of center stripe at same part, orbital bristles five in number, on one side at margin of lunule is another smaller bristle which I take to be abnormal; lunule brownish yellow, covered with white pollinosity; ocellar region subopaque; posterior ocelli occupying about one-fifth the width of vertex; antennæ black, rather below average size; second joint with apical bristles on outer side, the dorsal bristle distinct; third joint rounded, barely longer than broad, not distinctly pilose; arista black, paler at base, swollen on basal fourth, almost bare, in length reaching almost from its base to upper orbital bristle; face and cheeks black-brown; slightly gray dusted; the former in profile almost perpendicular, center raised slightly, but not sharply keeled; cheeks at posterior margin about one-sixth the eye height, anteriorly becoming linear; marginal bristles strong, anterior two higher than vibrissa; vibrissa strong; proboscis yellow; palpi black, slightly spatulate, bristles weak. Mesonotum black, slightly shining, grayish dusted; four pairs of dorso-centrals present, these are reduced in size anteriorly; the setulæ between the dorso-centrals in about 10 irregular rows, the two bristles between posterior dorso-centrals distinct, separated from each other by almost twice the distance between them and the dorso-centrals; pleuræ black, shining, sutures brownish; squamæ brownish yellow, fringe brown; scutellum and postnotum concolorous with pleuræ. Abdomen shining black. Sixth segment elongated; base of ovipositor shorter than preceding segment; all segments with numerous hairs, those on apices of segments, and especially the sixth, bristle like. Legs black, shining; knees brownish; fore femur with long ventral bristles; the posterior bristles on mid tibia present, but very short in type. Wings yellowish brown at base; subcostal vein complete, rather distinct; second costal division slightly more than twice as long as first; inner cross vein slightly beyond end of first vein, outer at length of inner from that vein, and distinctly before wing middle, veins 2-3-4 very noticeably divergent at apices; penultimate section of fifth distinctly shorter than ultimate section. Halteres yellow, knobs whitish.

Length, 4 mm.

Type: Cat. No. 15572, U. S. N. M.

Locality: Long Lake, Adirondack Mountains, (Horvath).  
One female.

Food-plant unknown.

Named in honor of Mr. W. R. Walton of the Bureau of Entomology.

29. *Agromyza angulata* Loew.

Plate XXIX, Fig. 16; Plate XXX, Fig. 18.

Syn: *Agromyza angulata* Loew, Dipt. Amer. Sept. Indig., Cent. 8, 1869, species 87.

Male and Female: Frons deep black, with sometimes a slight indication of paler color very narrowly along the inner margin of orbits; central stripe opaque, orbits shining; breadth of frons distinctly over one-third the head width, of orbits about one-half the width of center stripe; generally 5 orbital bristles present; in addition to the bristles there are numerous short hairs nearer to eye margin, forming an irregular row from opposite insertion of antenna to upper bristle; ocellar region glossy black; antennæ black, of moderate size; dorsal bristle on second joint distinct; third joint rounded at apex; arista brown, basal fifth yellowish and swollen, pubescence very short, length of arista equal to from its base to between upper two orbital bristles; face and cheeks black, or black brown, opaque; the former with a slight central keel, and a little produced at mouth margin; cheeks almost linear, very little higher at posterior margin than at anterior; marginal bristles in a double row, of moderate strength; vibrissa well differentiated; proboscis yellow; palpi black, of normal size and shape. Mesonotum glossy black, lateral margins sometimes brownish; four pairs of dorso-centrals present, the posterior pair strong, the others gradually reduced towards anterior pair, which are rather weak and slightly in front of suture; 7-8 irregular rows of short setulæ between dorso-centrals; no distinctly differentiated pair of bristles between posterior dorso-centrals; pleuræ glossy black, very narrowly lemon yellow along upper margin to humerus, narrowly along vertical mesopleural suture, more broadly at upper angles of that suture and below wing base; postnotum and scutellum colored as disk of mesonotum, squamæ whitish yellow, fringe whitish. Abdomen ovate, glossy black, sometimes with the segments very narrowly pale yellow, or brownish; sixth segment elongated; all segments with numerous surface hairs; apical margin of sixth segment with moderately long bristles; hypopygium of male of moderate size, colored as abdomen, base of ovipositor of female glossy black. Legs black, shining; fore knees pale yellow, knees of hind pairs, fore tibiæ and tarsi brownish, or yellowish; mid tibia without posterior bristles. Wings clear; bases of thick veins lemon yellow; first costal division one-half as long as second; outer cross vein below, or slightly beyond end of first vein; subcostal vein indistinct; first two sections of fourth vein subequal, or the first slightly the shorter; last section of fifth twice as long as penultimate section; veins 2-3-4 slightly divergent. Halteres pale yellow.

Length 1.5-2 mm.

Originally described from Pennsylvania (Osten Sacken), and since recorded from New Jersey, (Smith Cat.). Represented in U. S. National Museum collection by four specimens from



Lafayette, Indiana, (P. Luginbill) Webster's No. 9700, reared from timothy grass, and two specimens with the No. 6719, July 13, 1895, District of Columbia. There is one specimen in C. W. Johnson's collection from Auburndale, Massachusetts.

30. *Agromyza setosa* Loew.

Syn: *Agromyza setosa* Loew, Dipt. Amer. Sept. Indig., Cent. 8, 1869, species 83.

Male and Female: Frons black or black-brown; center stripe opaque; orbits shining; width of frons equal to slightly over one-third the width of head; orbits about one-half as wide as center stripe; five orbital bristles present, situated nearer to inner than outer margin of orbits; in addition to the bristles there are numerous short hairs present, between the eye margins and the bristles, which are particularly numerous on the lower half of orbit and terminate in an irregular row at about level of upper orbital bristle; ocellar region shining; ocellar triangle slightly indicated, shining; antennæ black, moderately large; second joint slightly over the average size, with numerous hairs, the usual bristle distinct; third joint rounded at apex, barely longer than broad, covered with short brownish pilosity; arista brown, for a short space paler beyond the distinctly thickened base; pubescence short but distinct, very close; length of arista equal to from its base to the second uppermost orbital bristle; face and cheeks black-brown; the former perpendicular and with a rounded central keel; cheeks increasing in height from anterior to posterior margin, where they are about one-fourth the height of eye; marginal bristles of moderate length, in two rows, and rather numerous, the upper row upwardly directed; vibrissa differentiated; probocis brown; palpi black, of moderate size, rather numerous bristled; eyes microscopically haired. Mesonotum subshining black; thickly covered with hairs and with four pairs of dorso-central bristles, the anterior pairs much reduced and the front pair not much stronger than the other dorsal hairs; the pair of bristles between the posterior dorso-centrals distinct, and of moderate length; pleuræ concolorous with disk of mesonotum, only brownish below wing base; squamæ brown, fringe concolorous; postnotum and scutellum colored as pleuræ. Abdomen concolorous with thorax; the surface rather thickly covered with hairs; sixth segment with some bristle-like hairs on posterior margin; hypopygium of male almost similar to that of *parvicornis*; ovipositor of female with base thickly covered with hairs. Legs black, tibiæ and tarsi black brown; posterior bristles on mid tibiæ very weak. Wings grayish, veins brown; first costal division nearly one-half as long as second; subcostal vein indistinct, almost coalescent with first at its apex; costa thickened at end of first vein; inner cross vein at slightly beyond end of first vein or at just below it; outer cross vein at slightly beyond wing middle, and at slightly more than its own length from inner cross vein; last section of fifth vein about one-half as long as penultimate section; veins 3-4 only slightly divergent at apices. Halteres yellow, stalk darkened at base.

Length 3-4 mm.

Originally described from District of Columbia (Osten Sacken). Represented in U. S. National Museum collection by 3 specimens, one from Monroe, Michigan, no other data; one with the number 2464—, and the third with label to the effect that it was reared from wild rice (*Zizania aquatica*) August 8, 1891, District of Columbia, (T. Pergande). The other records given by Coquillett for this species in Bull. No. 10, n. ser. 1898, Dept Agric., Div. Ent. refer to *fragaria* and *maculosa*.

There is a male specimen in the U. S. National Museum collection which represents probably a distinct species, but its condition is not good enough to permit me deciding the question, as the species of the group are all very closely allied.

Locality: San Mateo County, California (C. F. Baker).

### 31. *Agromyza isolata*, new species.

Female: Frons black-brown; center stripe opaque, orbits shining; breadth of frons a little over one-third the width of head; orbits slightly differentiated from center stripe, and each about one-fourth as wide; four long orbital bristles present, situated about on middle of orbits; the short hairs sparse and in a short irregular row; ocellar region raised, shining; ocellar triangle not distinguishable; antennae black-brown; second joint with numerous short, apical marginal hairs, and the dorsal bristle distinct, third joint slightly longer than broad; the upper extremity less distinctly rounded than the lower, covered with rather distinctive pile, which is brownish in color, and most distinct on dorsal surface at apex; arista brown, the swelling at base short and glossy; pubescence very short; length of arista equal to from its base to upper orbital bristle; face brown-black, perpendicular, almost without a central keel; cheeks nearly linear, brown-black; marginal bristles in two rows of moderate strength; vibrissa distinctly differentiated, the bristles continued above level of vibrissa; eye apparently bare, about one and one-half times as high as long; proboscis yellow; palpi black. Mesonotum black, shining, but not glossy; four pairs of distinct dorso-centrals present, the posterior pair most widely placed and strongest, the anterior pair of moderate strength, distinctly longer than discal setulae, and appreciably in front of suture; about 7 irregular rows of setulae between the rows of dorso-centrals; the pair of bristles between the posterior dorso-centrals as long as anterior dorso-central pair; pleurae black-brown, glossy, narrowly paler along upper margin and sutures, yellowish beneath wing base; squamae yellowish white, margin and fringe brown; postnotum and scutellum concolorous with disk of mesonotum. Abdomen ovate in shape, glossy black, apical segment yellowish brown at apex, base of ovipositor longer than preceding segment; hairs on ovipositor yellowish, on abdomen and thorax brownish. Legs yellowish brown, the femora blackened; all legs with num-

erous hairs, which are yellowish in color; mid tibia with the posterior bristles small. Wings clear; second costal division about two and one-half times as long as first; subcostal vein distinct, evidently coalescent with first at apical fourth; inner cross vein at slightly before end of first vein; outer at slightly beyond wing middle, and at one and one-half times its own length from inner; veins 3-4 slightly divergent at apices; last section of fifth vein rather over two-thirds as long as the penultimate section. Halteres yellow, knob whitish.

Length 2 mm.

Type: Cat. No. 15573, U. S. N. M.

Locality: Eureka California, May, (H. S. Barber).

Food-plant unknown.

32. *Agromyza fragariæ*, new species.

Plate XXVIII, Fig. 5.

Male and Female: Frons dark brown, or black brown; center stripe opaque; orbits subopaque; breadth of frons distinctly over one-third the width of head; orbit one-fourth as broad as center stripe; four orbital bristles present, the hairs on orbits not numerous; ocellar region shining, black, raised, frontal triangle not distinguishable; antennæ black, sometimes with indications of paler color at apex of second joint on inner surface; rather below the average in size; second joint with weak apical hairs, and the dorsal bristle distinct, third joint not longer than broad, rounded in front, and covered with short brownish pile; arista brown, thickened on basal fourth, the pubescence close, but very short; length of arista equal to from its base to slightly beyond second uppermost orbital bristle; face shining black, perpendicular, keel very slight; cheeks pale brown, linear at anterior margin, about one-third as high as eye at posterior margin; marginal bristles in a double row, numerous, of moderate length, extending above level of vibrissa, which is distinctly differentiated; proboscis yellow; palpi black. Mesonotum subopaque, black, with slight indications of grayish dusting; four pairs of dorso-centrals present, which become shorter towards front, the anterior pair slightly in front of suture; 6-7 irregular rows of setulæ between the dorso-centrals; the pair of bristles between the posterior pair of dorso-centrals distinctly differentiated from the discal setulæ, about as long as anterior pair of dorso-centrals; pleuræ shining black-brown, the suture yellowish brown; squamæ whitish, fringe brownish-yellow; postnotum and scutellum black, subshining. abdomen shining black, subovate in female, elongate in male; covered with hairs, those on posterior margins of segments bristle-like; the dorsal hairs on abdomen and mesonotum are brownish yellow. Legs rather slender, black-brown, tibiæ and tarsi paler; posterior mid tibial bristles minute. Wings elongate, grayish; first costal division one-third as long as second; subcostal vein rather distinct, almost coalescent with first at its apex; inner cross vein at slightly before end of first vein, and at middle of discal cell; outer cross vein at about one and one-half

times its own length from inner and at wing middle; last section of fifth vein about two-thirds as long as penultimate section; veins 3-4 gradually and slightly divergent. Halteres yellow.

Length 1.5-2 mm.

Type: Cat. No. 15574, U. S. N. M.

Locality: Placer County, California, November, mining leaves of strawberry, (A Koebele).

Three specimens.

### 33. *Agromyza posticata* Meigen.

Plate XXXI, Fig. 29.

Syn: *Agromyza posticata* Meigen, Syst. Besch., Vol. VI, 1830, p. 172, species 16.

*Agromyza terminalis* Coquillett, Proc. Acad. Nat. Sci. Phil. 1895, p. 318.

*Agromyza taeniola* Coquillett, Proc. Ent. Soc. Wash., Vol. VI, 1904, p. 191.

Male and Female: Frons black, center stripe opaque, orbits shining, breadth of frons less than one-third the head width; four orbital bristles below anterior ocellus, small hairs on orbits microscopic in male, strongest in female; lunule silvery white pollinose; antennæ brown, of normal size; dorsal bristle on second joint distinct, apex of same joint with numerous short hairs, which are most distinct on the under side; third joint rounded, covered with short, pale pilosity; arista brown, pale yellowish on basal elongate swelling, very thickly covered with short pubescence, which is not longer than the basal diameter of arista; arista as long as from its base to beyond upper orbital bristle; eyes microscopically haired, cheeks and face brown; the latter concave in profile, keel slight; cheeks linear at anterior margin, at posterior margin very slightly broadened, marginal bristles, 5-7, of moderate strength; vibrissa strong; proboscis yellow; palpi brownish yellow, normal in size, with weak end bristles. Mesonotum glossy brownish-black, margins and humeri pale brown, with an indication of yellow along suture between margin of disk and pleuræ; three distinct pairs of dorso-centrals present, in one specimen an additional bristle is visible on one side anterior to the front pair; 5-6 irregular rows of setulæ between dorso-centrals, the pair of bristles between posterior dorso-centrals distinctly differentiated from setulæ but much weaker than dorso-centrals; pleuræ glossy brown, yellowish along suture and below wing base; scutellum and postnotum concolorous with disk of mesonotum; squamæ whitish, fringe white. Abdomen glossy black-brown; apical three segments and hypopygium of male pale yellow, of female posterior margin of sixth segment distinctly pale yellow; apical segments brownish, ovipositor glossy black; last abdominal segment in male slightly elongated; all segments with numerous short black hairs, the apical segments with unusually weak posterior marginal bristles. Legs brown-black, glossy, knee joints paler; mid-tibia with posterior bristles present, in some cases those number three, instead of the normal two. Wings yellow at base; first costal division almost one half as long as second; inner cross-vein at below, or slightly beyond, end of first vein; subcostal vein indistinct, but complete;

outer cross vein at slightly beyond wing middle, and at rather more than its own length from inner cross vein; last section of fifth vein about two-thirds as long as penultimate section; veins 2 and 3 distinctly, 3 and 4 slightly divergent at apices. Halteres yellow, knob whitish.

Length 3-4 mm.

Localities of male specimens in collection: Delaware county, Pennsylvania, July 23, 1893 (collection Coquillett), the type of *terminalis* Coquillett; Franconia, New Hampshire, (Mrs. A. T. Slosson); White Mountains, New Hampshire (Morrison); District of Columbia, June (collection Coquillett); Oswego, New York, July 7, 1897; and Athens, Tennessee, August, (H. S. Barber).

The female has the apical abdominal segments so much less distinctly pale than the male, that it is with difficulty one associates it with that sex. So dissimilar are the sexes that Coquillett in describing *terminalis* failed to associate with the male two females taken at the same time and place.

It was this sex which he recorded\* as *neptis* Loew, from Chicago. There are females in collection from Delaware county, Pennsylvania, Plummers Island, Maryland, August 3, 1912 (J. R. Malloch); Georgia (no other data); and a specimen reared from mine in leaves of Solidago, July 20, 1884, Virginia (T. Pergande). I have also seen a male and female taken by W. L. McAttee, on Plummers Island, Maryland; and specimens in C. W. Johnson's collection from the following localities: Hanover, New Hampshire; Machias, Maine; Eastport, Maine; Chester, Massachusetts; Winnipauk, Connecticut; Danbury, Connecticut, Rowayton, Connecticut; Buttonwoods, Rhode Island; Norwich, Vermont, and Cornish, New Hampshire. The type specimen of *taeniola* Coquillett is a male of this species.

A peculiarity about this species is that after death the eyes are red, whereas in practically all the other species they become brown or black.

#### 34. *Agromyza neptis* Loew.

Syn: *Agromyza neptis* Loew, Dipt. Amer. Sept. Indig., Cent. 8, 1869, species 93.

Male: Frons black, one-third as wide as head; center stripe opaque brown-black; orbits glossy, each orbit about one-third as wide as center stripe; four orbital bristles present, the hairs on orbits in an irregular row between bristles and eye margin; ocellar region raised, glossy black; antennæ black, rather above the average size; second joint

\*Bull. 10, n. ser., 1898, Dept. Agric. p. 78.

with rather weak dorsal bristle, and weak apical marginal hairs; third joint large, distinctly longer than broad, covered with distinct pale pile; arista brown, tapering, distinctly and thickly covered with short pubescence, which is about as long as basal diameter of arista; length of arista equal to three times the length of third antennal joint; face subshining, black, rather long, concave in profile, central keel slight, but sharp; cheek black, almost linear, slightly higher at posterior margin. Marginal bristles weak; vibrissa weakly differentiated, eye distinctly higher than long; proboscis yellow; palpi black, normal. Mesonotum glossy black, thickly covered with rather long setulæ, three pairs of dorso-centrals present, the anterior pair weak; the pair of bristles between the posterior dorso-centrals as long as second pair of dorso-centrals; pleuræ glossy black, with a slight indication of pale color along upper margin, and distinctly pale below wing base; squamæ yellowish white, fringe white; postnotum and scutellum concolorous with mesonotum, the apical pair of bristles on scutellum as strong as basal pair. Abdomen glossy black, similar in shape to that of *parvicornis*. Wings clear; first costal division almost one-half as long as second, inner cross vein at slightly beyond middle of wing and at distinctly more than its own length from inner; last section of fifth vein distinctly shorter than penultimate section. Halteres white.

Length 2 mm.

Originally described from District of Columbia (Osten Sacken). Aldrich gives it as from Nebraska, but probably refers to another record of the species. I have before me only one specimen which is referable to this species.

Locality: Plummers Island, Maryland, August 3, 1912 (J. R. Malloch).

Food-plant unknown.

### 35. *Agromyza inconspicua*, new species.

Male: Frons slightly over one-third the width of head; black, center stripe opaque, orbits and ocellar region shining; four orbital bristles present, orbits otherwise almost entirely bare; antennæ black, brownish at base; third joint small, rounded, not as long as broad, arista slightly swollen and tapering at base, pubescence very short, length of arista equal to from its base to upper orbital bristle; face black, concave in profile, slightly produced at mouth margin; center keel rounded; cheek brownish yellow, twice as high at posterior as at anterior margin, at highest part one-third as high as eye, marginal bristles of moderate strength, vibrissa slightly differentiated; proboscis yellow; palpi black; occiput linear on upper half. Mesonotum shining black, three pairs of dorso-centrals present, the anterior pair weak and anterior to the suture a setula which may, in other specimens, be strong enough to be classed as a dorso-central; disk very sparsely covered with setulæ, only three irregular rows between the dorso-centrals; no distinct bristles between the posterior pair of dorso-centrals; pleuræ

glossy black, median vertical suture narrowly pale yellow; scutellum sub-opaque, brownish-black; apical pair of scutellar bristles strongest. Abdomen rather narrow; shining black-brown; hypopygium normal in size. Legs black-brown, knees distinctly yellow; tarsi yellowish brown, no distinct bristles on posterior surface of mid tibia. Wings narrow, clear, veins on basal half pale yellow; costa brown, first division about half as long as second; inner cross vein at distinctly anterior to end of first vein and middle of discal cell; outer cross vein at distinctly more than its own length from inner and very slightly before middle of wing; veins 3-4 on last sections almost parallel; last section of fifth vein about one-fourth longer than penultimate section. Halteres yellow, knob whitish.

Length slightly over 1 mm.

Type: Cat. No. 15575, U. S. N. M.

Locality: Fort Collins, Colorado, reared from mine in *Agropyron*, July 28, 1910, (C. N. Ainslie). Webster's No. 6611.

### 36. *Agromyza dubitata*, new species.

Female: Frons black, center stripe opaque, orbits shining at base of bristles; breadth of frons a little over one-third the width of head, of each orbit about one-half the width of center stripe; four rather weak orbital bristles present, situated on near to inner margin of orbit; the orbital hairs less numerous than in *californiensis*; ocellar region shining black, raised, the ocelli in an equilateral triangle; antennæ black, rather smaller than in preceding species, the third joint not so regularly rounded at apex on upper surface; arista similar to *californiensis*, but slightly shorter; face brown-black, opaque, concave in profile; cheeks brown, almost as in preceding species; proboscis yellow; palpi spatulate, with several moderately strong end bristles; occiput narrow on upper half. Mesonotum shining black, bristled as in preceding species, but the pair of bristles between posterior pair of dorso-centrals shorter and more widely placed; pleuræ, squamæ, post-notum and scutellum as *californiensis*. Abdomen shining black; ovate; last segment with the hind marginal bristles moderately strong. Legs almost entirely black, the knees brownish, or the tibiæ and tarsi brown. Halteres yellow, knob paler.

Length 3-4 mm.

Type: Cat. No. 15576, U. S. N. M.

Locality: Beverly, Massachusetts, July 19, 1869, (Burgess). Other localities: Cottage Beaulieu, Ottawa, and Ile de Montreal, Ottawa, Canada, June and July, 1906. Nine specimens.

Food-plant unknown.

37. *Agromyza parvicornis* Loew.

Plate XXIX, Fig. 11; Plate XXXI, Figs. 35, 37.

Syn: *Agromyza parvicornis* Loew. Dipt. Amer. Sept. Indig., Cent. 8, 1869, species 92.

Male and Female: Frons black or black-brown, opaque, orbits slightly shining, black, four orbital bristles present; orbits differentiated from center stripe, bristles situated nearer inner than outer margin of orbits, a few weak hairs in an irregular row laterally beyond them; antennæ brown or brownish black, rather below the normal size; third joint short, rounded in front, thickly covered with soft, short, whitish pilosity; arista brown, generally yellowish near base, except on the short thickened portion which is glossy black; pubescence very close, generally distinct; length of arista equal to from its base to upper orbital bristle; face brown, nearly perpendicular in profile, the central keel slight; cheeks brown, or yellowish brown, very much higher posteriorly than anteriorly, at highest part one-third as high as eye; marginal bristles numerous; vibrissa differentiated, but not very strong; proboscis brown; palpi black, very slightly dilated, weakly bristled. Mesonotum glossy black; disk thickly covered with short setulæ; two pairs of dorso-centrals present; the bristles between the posterior pair distinct; pleuræ, scutellum and postnotum concolorous with disk of mesonotum, pleural sutures rarely, and beneath wing bases generally yellowish; squamæ whitish yellow, fringes brown. Abdomen colored as thorax; hypopygium of male as Fig. 35, Plate XXXI. Legs black, the tibiæ and tarsi sometimes paler, brownish yellow, most distinct on knee joints; mid-tibia with the posterior bristles distinct. Wings clear, slightly grayish on anterior half; venation as in figure, halteres yellow, the knob whitish.

Length 3-4 mm.

Originally described from District of Columbia, (Osten Sacken). Larva lives in mines in leaves of corn; occurs in the following states: Florida, District of Columbia, Indiana, Vermont, Maine, Massachusetts, Connecticut, New Hampshire, Wisconsin, Alabama, South Carolina, Illinois and Texas. Probably generally distributed throughout the United States. A full list of localities will be given in the bulletin in preparation dealing with the economic importance of this species and several others affecting field and forage crops.



38. *Agromyza viridula* Coquillett.

Syn: *Agromyza viridula* Coquillett, Jour. N. Y. Ent. Soc., Vol. X, 1902, p. 190.

Female: Frons black, center stripe opaque; orbits distinctly differentiated, shining; breadth of head one-third, or slightly over one-third, the head width; each orbit about one-fourth as wide as center stripe; four strong orbital bristles present, and beyond these, laterally, an irregular row of short hairs; lunule white pollinose; ocellar region shining black; antennæ of moderate size, second joint with distinct dorsal bristles and very weak apical hairs; third joint rounded, not as long as broad, covered with very short, whitish pile; arista thickened at base, tapering on basal third, bare, as long as from its base to anterior ocellus; face black, opaque, concave in profile, mouth margin slightly produced, keel very slight; cheek linear at anterior margin, at posterior margin about one-sixth as high as eye, marginal bristles moderately strong, increasing in length towards anterior margin; vibrissa differentiated; occiput not visible on upper half; proboscis yellow; palpi black, of moderate size, the bristles distinct. Mesonotum glossy black; the pair of bristles between posterior pair of dorso-centrals well defined; pleuræ glossy black, brownish below wing base; squamæ whitish, fringe white; bristles on scutellum subequal. Abdomen glossy black, with a distinct brassy sheen, ovate, bristled as in *parvicornis*. Legs shining black; tarsi brownish; mid tibia with posterior pair of bristles distinct. Wings clear, veins black-brown; second costal division  $2\frac{1}{2}$  times as long as first; subcostal vein distinct; fused with first at its apex; inner cross vein at slightly before end of first vein, and distinctly before middle of discal cell; outer cross vein at wing middle, and  $1\frac{1}{2}$  times its own length from inner cross vein; last section of fifth vein little over one half as long as penultimate section, sixth vein distinctly short of wing margin. Halteres with yellow stalk and white knob.

Length 2.5–3 mm.

Redescribed from type specimen (Cat. No. 6660, U. S. N.M.)

Locality: District of Columbia, June, (collection Coquillett). The other specimens in collection are from District of Columbia, July; Maryland, June; Georgia; Beverly, Mass.; June 29, 1876, (Burgess); and three specimens from the West Indies in poor condition that probably belong to this species, Aguadilla, and Mayaguez, Porto Rico, (A. Busck), and St. Domingo, (A. Busck). These specimens are slightly smaller than the type, but have no distinctive characters by which they may be separated. I have also seen one specimen submitted by Prof. Chittenden of the Bureau of Entomology, from Plano, Texas, June, 1907 (E. S. Tucker) No. 561. There are three specimens in Prof. Webster's material labelled "Reared from blotch mine red oak leaf, June 20, 1912." Lafayette, Indiana, (J. J. Davis).

39. *Agromyza salicis*, new species.

Plate XXIX, Fig. 15.

Male: Frons black, center stripe opaque brown-black, orbits and ocellar region shining; width of frons about one-half the head width; each orbit about one-half as broad as center stripe; five distinct orbital bristles present, the hairs between these and the eye margin rather conspicuous and numerous; antennæ black; rather small; third joint rounded, distinctly shorter than broad; arista brown; swollen on basal fourth; pubescence very short, but distinct; length of arista not as long as from its base to second uppermost orbital bristle; face black, subopaque, retreating towards mouth margin; cheek brown-black, distinctly higher at posterior than at anterior margin, at highest point more than one-half as high as eye; marginal bristles of moderate strength; vibrissa hardly differentiated; proboscis yellow; palpi black, of moderate size. Mesonotum shining black; three distinct pairs of dorso-centrals present; the anterior pair distinctly weaker than the other two pairs, and close to suture; the pair of bristles between the posterior pair of dorso-centrals weakly differentiated; pleuræ shining black, brownish along sutures and below wing base; squamæ grayish, fringe dark brown; scutellum and postnotum concolorous with disk of mesonotum, the former with the bristles subequal. Legs black; mid tibia without distinct posterior bristles. Abdomen black-brown, shining, covered with short setulæ; hypopygium glossy black, small. Wings rather narrow; second costal division  $2\frac{1}{2}$  times as long as first; subcostal vein distinct; fused with first at its apex; inner cross vein at about apex of junction of first vein with costa; outer cross vein at distinctly, but not greatly, before wing middle, and at slightly more than its own length from inner cross vein; last section of fifth vein subequal with penultimate section; sixth vein indistinct. Halteres black.

Length 2 mm.

Type: Cat. No. 15577, U. S. N. M.

Locality: Reading, Massachusetts, May 16, 1908. New York State Collection, from Willow, (E. P. Felt). One male.

40. *Agromyza winnemanæ*, new species.

Female: Deep black, glossy; abdomen with an indication of metallic bluish sheen. Frons deep black, center stripe opaque; orbits glossy; width of frons slightly more than one-third the head width; each orbit a little less than one-fourth the width of center stripe; four orbital bristles present; an irregular row of weak hairs between eye and orbital bristles; antennæ of moderate size; second joint with distinct dorsal bristle; third joint barely longer than broad, rounded at apex; arista swollen at base, tapering, bare, in length equal to from its base to second uppermost orbital bristle; face brownish black, opaque; almost perpendicular in profile, with slight, rounded keel; cheek very short, almost linear, not over one-eighth as high as eye, marginal

bristles weak; vibrissa distinctly differentiated though not very strong; proboscis brown; palpi black, normal; occiput linear, the eyes very large and occupying nearly the whole side of head. Mesonotum with two pairs of dorso-centrals; disk covered with short setulæ; the pair of bristles between the posterior dorso-centrals not differentiated from the other discal setulæ; squamæ yellowish brown, fringe brown; apical bristles on scutellum weaker than the basal pair. Abdomen with segments covered with short setulæ, those on the posterior margins slightly stronger; sixth segment slightly elongated; base of ovipositor not as long as preceding segment. Legs shining black; posterior surface of mid tibia, in type, without any bristles. Wings clear; second costal division a little over twice as long as first; subcostal vein indistinct, coalescent with first at its apex; outer cross vein at distinctly before wing middle, and at its own length from inner; fourth vein rather indistinct from outer cross vein to apex; last section of fifth distinctly, but not greatly, longer than penultimate section; costa not reaching beyond end of third vein. Halteres black.

Length 3 mm.

Type: Cat. No. 15578, U. S. N. M.

Locality: Plummers Island, Maryland, June 27, 1909, (W. L. McAtee), one female.

Food-plant unknown.

#### 41. *Agromyza simplex* Loew.

Syn: *Agromyza simplex* Loew, Dipt. Amer. Sept., Cent. 8, 1869, species 84.

Male and Female: Entirely shining black. Frons occupying distinctly more than one-third the width of head; center stripe opaque; orbits glossy; ocellar region glossy; the frontal triangle distinguishable, but not separated from center stripe by an impressed line; five orbital bristles present, in addition to those there are numerous soft hairs covering the entire surface, laterally, beyond the bristles, and stretching from opposite base of antennæ to upper orbital bristle; antennæ rather small, second joint with moderately long dorsal bristle; third joint rounded, with very short, whitish pile; arista bare, the base swollen, length of arista equal to from its base to between uppermost two orbital bristles; face slightly keeled, concave in profile, opaque, brown-black; cheeks opaque brown; orbits carried almost to hind margin of eye, shining; height of cheek at anterior margin less than at posterior, where it is about two-fifths as high as eye; marginal bristles rather weak, upturned; vibrissa weakly differentiated; proboscis brown; palpi black, normal. Mesonotum covered with short setulæ; two distinct pairs of dorso-centrals present, and in addition to these there are generally 2-3 setulæ anterior to them stronger than the discal hairs; squamæ black-brown, fringe concolorous; scutellum with the apical two bristles weaker than the basal two. Abdomen broadly ovate in female, somewhat narrower in male; no metallic sheen visible; last abdominal segment in female elongate; apical bristles on segments not conspicuous; base of ovipositor not longer than preceding

segment; male hypopygium exposed, rather small. Legs entirely black; mid tibia with the posterior bristles present, but weak. Wings grayish; veins black; subcostal vein indistinct, joining first vein near its apex; first costal division half as long as second; inner cross vein at below end of first vein; outer cross vein at about one-half its own length from inner; last section of fifth vein slightly longer than penultimate section. Halteres black.

Length 2.5-3 mm.

Originally described from the Middle States. Recorded in the Smith Catalogue for New Jersey, and from New York in Bull. 189, N. Y. Exper. Sta. 1900. Represented in collection by two specimens from Berlin, Germany, (C. Schirmer) labeled *Agromyza schineri* Loew, in Coquillett's handwriting. The only other specimen I have ever seen was reared from asparagus by I. J. Condit, Portsmouth, Virginia, submitted by Prof. Chittenden of the Bureau of Entomology.

This species attacks asparagus and in the New York Bulletin above mentioned is an account of its life history. Giard\* has found it in France, and Collin† in England, associated with the same plant.

42. *Agromyza vibrissata*, new species.

Plate XXVIII, Fig. 2; Plate XXX, Figs. 24, 25.

Male: Frons opaque brown-black, only the orbits and ocellar triangle slightly shining; breadth of frons nearly one-half the head width; six orbital bristles present, the lower, or anterior, two lying close to surface of the frons, which is rather buccate, and pointing backward and slightly inward; numerous closely placed short hairs on orbits between bristles and eye margin; lunule depressed; face sunk in and with a central keel, which is raised on a level with eye orbits; antennæ brown, rather small and half hidden in face cavities; arista yellowish brown, distinctly swollen at base, bare, not three times as long as third antennal joint; face black, a yellowish brown patch on center of epistome; epistome much produced; cheeks brown; eye orbit distinct; cheek, including orbit, two-fifths as high as eye; marginal bristles weak, vibrissa formed of a fasciculus of bristles, which is about two-fifths as long as length of cheek; proboscis yellowish-brown; palpi black, slightly spatulate, and weakly bristled. Mesonotum shining black; covered with short setulæ and with two pairs of dorso-central bristles; the pair of bristles between the posterior dorso-centrals not differentiated; pleuræ glossy brown-black, the sutures, and below wing base paler; the normal bristles present, squamæ yellowish, fringe brown; scutellum, and postnotum concolorous with disk of mesonotum; the former with the posterior pair of bristles slightly reduced

\*Bull. Soc. Ent. France, 1894, p. 179.

†Ent. Mon. Mag., Vol. XXII, 1911, p. 254.

in size. Abdomen glossy black; all segments with numerous short hairs on dorsum; those on lateral margins of segments longer; the posterior margin of last abdominal segment not noticeably bristly; last segment slightly elongated; hypopygium small. Legs black-brown, shining, tibiae and tarsi paler; posterior bristles on mid tibia present, but not large. Wings clear; veins brown; first costal division fully one-half as long as second; subcostal vein indistinct, fused with first at near apex; inner cross vein below swelling caused by junction of first vein and costa; outer cross vein at wing middle, and at nearly its own length from inner; last section of fifth vein slightly shorter than penultimate section. Halteres black.

Length 3.5 mm.

Female: Similar in color and size to the male, but the cheeks as in figure 25; the last segment of abdomen has the bristles at apex stronger than in the male; and the ovipositor is glossy black.

Type: Cat. No. 15579, U. S. N. M.

Locality: Georgia, no other data on specimens. Two males, one female.

Food-plant unknown.

43. *Agromyza affinis*, new species.

Female: Frons black, center stripe opaque, orbits shining; breadth of frons slightly over one-third the head width; orbits less than one-half the width of center stripe: four strong orbital bristles present, on both sides there is a weaker bristle close under the front one; hairs on orbits, between bristle and eye margin, short, but numerous, on front half of orbit; antennae black, of moderate size; second joint with distinct dorsal bristle; third joint rounded, pilosity very short, dark; arista black, basal swelling slight and tapering, pubescence very short and close; length of arista equal to from its base to a little beyond second uppermost orbital bristle; face black, opaque, concave in profile, mouth margin produced, keel distinct; cheek black, brown on lower half, higher anteriorly than posteriorly, vibrissa very clearly differentiated from the marginal bristles; proboscis brown; palpi in type retracted. Mesonotum shining black; two distinct pairs of dorso-centrals present; disk covered with short setulae, which are carried back beyond the transverse line of the posterior pair of dorso-centrals; pleurae shining black, brownish along sutures and below wing base; squamae brown-black, fringe almost black; scutellum concolorous with disk of mesonotum. Abdomen glossy black; all segments with discal setulae; those on posterior margin of sixth segments most noticeable, but not strong; base of ovipositor distinctly longer than preceding segment, its surface covered on the sides and apex with short hairs. Legs entirely black, shining; posterior surface of mid tibia without distinct bristles. Wings grayish, veins brown; outer cross vein at distinctly less than its own length from inner, and at wing middle; last section of fifth vein distinctly shorter than the penultimate section. Halteres black.

Length 2 mm.

Type: Cat. No. 15580, U. S. N. M.

Locality: Glen Echo, Maryland, June 3, 1898 (R. P. Currie). This species comes very close to the European *curvipalpis* Zetterstedt, but the two males of that species in collection (Bonhill, Dumbartonshire, Scotland, May, 1907-1908, J. R. Malloch) have the arista bare, the basal swelling much more pronounced, and elongate; the frons half as broad as width of head; the last section of fifth vein about equal to the penultimate section, and the outer cross vein before wing middle. It may be well to indicate here that the name *curvipalpis* (Dipt. Scand. Vol. 7, 1848, p. 2782, species 44) was given to this species because of a misapprehension on the part of Zetterstedt, who mistook the vibrissæ for a prolongation of the palpi. Schiner in *Fauna Austriaca* followed him in this respect. The species was afterwards described by Kaltenbach as *bicornis* (Pflanzenf. 1873, p. 330, species 33).

In the collection are three specimens which may be males of *affinis*, but their condition is so poor that I do not consider it desirable to either place their description on record as such, or describe them as belonging to another species.

The localities are, Key West, Florida, January 1 and February 6, 1869, (Hubbard-?) and one from North Carolina, without other data.

Food-plant unknown.

44. *Agromyza insularis*, new species.

Plate XXXI, Fig. 38.

Male and female: Frons black; center stripe opaque, orbits and the weakly defined ocellar triangle shining; breadth of frons in female barely one-third as wide as head, in male slightly wider; each orbit equal to about one-fourth the width of center stripe; four rather weak orbital bristles present; in addition to the bristles there is an irregular row of very short hairs nearer to eye margin; frons in profile declivitous, not projecting; antennæ brown-black, small; third joint not as long as broad, rounded in front, distinctly pilose; arista black, basal fifth thickened, tapering, almost bare, length equal to from its base to second uppermost orbital bristle; face black, concave, mouth margin slightly produced; cheek black-brown, narrow, almost linear at posterior margin, distinctly higher anteriorly, but not very much produced; vibrissa in male fasciculate in form, the length not equal to that of cheek, and not very conspicuous; in female the vibrissa is distinct and almost as long as in male, but consisting on only one bristle; marginal cheek bristles much weaker than vibrissa; proboscis brownish

yellow at apex; palpi black, rather short and slightly spatulate, the bristles weak; occiput linear. Mesonotum shining black; two pairs of dorso-centrals present; the discal setulæ very sparse behind anterior pair of dorso-centrals, and not carried to level of transverse line of posterior dorso-centrals; pleuræ glossy brown or blackish, margin and fringe black-brown; scutellum concolorous with disk of mesonotum, the bristles subequal. Abdomen glossy black; ovate; segments with numerous short setulæ, posterior margins with more distinct bristle-like setulæ; base of ovipositor glossy black. Legs black. Wings grayish; veins black-brown; second costal division slightly more than twice as long as first; subcostal vein indistinct, coalescent with first at its apex; inner cross vein at below end of first; outer at its own length from inner, and at slightly before wing middle, last section of fifth vein barely longer than penultimate section; veins 3-4 slightly divergent on last sections. Halteres black.

Length barely 1.5 mm.

Type: Cat. No. 15581, U. S. N. M.

Locality: Cayamas, Cuba, December (E. A. Schwarz). Male and female, taken in cop.

45. *Agromyza texana*, new species.

Male and Female: This species is very similar to *insularis* in general appearance, but differs as follows: The arista is not so much swollen at base, nor for such a long distance; the cheek is much more distinctly produced in both sexes, and comparatively higher anteriorly; the vibrissa is much more conspicuous in the male, and as long as cheek length, in female the vibrissa is comparatively weak and not nearly so long as in male, consisting of one hair only; the thorax is more densely covered with setulæ, which are carried at least to level of transverse line of posterior dorso-centrals; the legs are black in both species and the posterior bristles are absent from mid tibiæ; the wings have the outer cross vein at wing middle, or very slightly beyond it, and the last section of fifth vein slightly shorter than penultimate section.

Length 1.5-2 mm.

Type: Cat. No. 15582, U. S. N. M.

Locality: Brownsville, Texas, January 27, 1909 (Mc-Millan and Marsh). reared from Roripa. One male.

Paratypes: Cabin John Bridge, Maryland, April 28, 1912, two females (Knab and Malloch); Brownsville, Texas, January 27, 1909, one female, same data as type; and one female Veitch, Virginia, June 9, 1912 (F. Knab).

46. *Agromyza abnormalis*, new species.

Plate XXIX, Fig. 9.

**Female:** Frons black-brown; center stripe opaque; orbits black, shining; breadth of frons over one-third that of head; orbits at widest part one-third as wide as center stripe at that part; five strong orbital bristles present, and in the type a weak one anterior to the lower strong one; upper two bristles situated near to inner margin of orbits, the others nearer to center; besides the bristles there are scattered short hairs present on the orbits nearer to eye margin than bristles; ocellar region raised, shining black; ocellar triangle not defined; frons in profile slightly protruding anteriorly; antennæ black-brown, of moderate size; dorsal bristle on second joint distinct; third joint rounded in front, slightly longer than broad, pilosity very short; arista rather thick, swollen more distinctly on basal fifth, pubescence short, but distinct; length of arista equal to from its base to upper orbital bristle; face shining black, slightly retreating, mouth margin not produced, center keel very slight; cheek opaque brown, half as high anteriorly as posteriorly, where it is half as high as eye; marginal bristles of moderate length; the vibrissa slightly differentiated; proboscis yellow; palpi black, normal; occiput slightly projecting. Mesonotum black, subshining; four pairs of dorso-centrals present, the anterior pair in front of suture, discal setulæ numerous and rather regularly arranged in rows, of which there are about five between the dorso-centrals; no differentiated bristles between posterior pair of dorso-centrals; pleuræ shining black, the sutures and below wing base brown; squamæ gray-brown, margins black-brown, fringe brown; scutellum concolorous with disk of mesonotum, the bristles subequal. Abdomen black, glossy; segments rather strongly setulose; ovipositor very glossy black. Legs black, tibiæ and tarsi brownish; mid tibia without posterior bristles. Wings grayish; first costal division distinctly over one-half as long as second; subcostal vein indistinct, but complete, not fused with first at its apex; inner cross vein distinctly, but not greatly in front of end of first vein, and at or slightly beyond middle of discal cell; outer cross vein at about its own length from inner and very slightly beyond end of first vein; veins 3-4-5 gradually and slightly divergent on their last sections; last section of fifth vein twice as long as penultimate section. Halteres brown.

Length 3 mm.

Type: Cat. No. 15583, U. S. N. M.

Locality: Washington, District of Columbia, June, 1903, No. 9727—"on Aphid"—"On roots of *Amaranthus*."

Paratype: labeled "Twilight" Lawrence, Kansas, (E. S. Tucker).



47. *Agromyza virens* Loew.

Dipt. Amer. Sept. Indig. Cent. 8, 1869, species 84.

Male and Female: Frons black, orbits and ocellar triangle glossy, center stripe opaque; breadth of frons slightly over one-third that of head; breadth of orbits over one-third that of center stripe; five orbital bristles generally present, the orbits densely covered with short, fine, hairs; frons generally slightly buccate; antennæ brown-black, of moderate size; third joint rounded; arista slightly swollen at base, very thickly, but shortly pubescent; as long as from its base to upper orbital bristle; face concave in profile, brown-black; cheeks higher at posterior than anterior margin, at highest part about one-fourth as high as eye; marginal bristles of moderate strength; vibrissa differentiated; proboscis brown; palpi black, normal; occiput slightly projecting; eyes generally distinctly and thickly pubescent above. Mesonotum glossy black, with sometimes a bluish or greenish tinge; squamæ white, or yellowish, the margin yellowish, fringe pale yellowish, or white. Abdomen glossy black, generally with a metallic tinge, either bluish, greenish, or bronzy; in shape and vestiture as in *tilia*. Legs as in *tilia*; the posterior mid tibial bristles distinct. Wings grayish, or almost clear, veins brown; venation almost as in *tilia*.

Length 1.5–2.5 mm.

Specimens from Lafayette, Indiana (F. M. Webster). Mining in roots of clover. There are five other specimens in collection with Webster's No. 10,073, from Lafayette, Indiana; one from Gladbrook, Iowa, February 14, 1890, (No. 4608) mining in stems of *Ambrosia artimisaefolia* (A. M. Sharp); two from Cambridge, Massachusetts, "mining in stems of a weed" (H. G. Hubbard); one marked 30420, referred to as a Tachinid in notes, from stem of a weed in which some species of Cecidomyid was mining, April 18, 1883 (locality doubtful); two specimens labeled "Parasitic on Cecidomyid on aster with yellow flowers," May 23, 1884 (locality doubtful); two from stems of *Ambrosia*, March, 1895, District of Columbia, one from *Nabalus albus*, May 14, 1883 (locality doubtful); two from California (Alameda and Los Angeles), collection Coquillett; one from Georgia, no other data; one from Flagstaff, Arizona, July, (H. S. Barber). One from Plummers Island and four from Washington, D. C. are in the collection of W. L. McAtee and a series of 13 specimens from the Brodie collection are in the U. S. National Museum collection, locality Toronto, Ontario, Canada.

In some cases, I believe with specimens which have been on the wing, it is not very easy to see the hairs on the eyes, but in freshly emerged examples these are very noticeable on

the upper surface of the eyes close to the orbits. A single specimen from Claremont, California (Baker), may belong to a distinct species.

48. *Agromyza cærulea*, new species.

Plate XXIX, Fig. 13.

Female: Frons black; center stripe opaque brown-black, orbits and ocellar triangle glossy black; width of frons equal to slightly over one-third that of head; each orbit slightly less than one-fourth the breadth of center stripe; four strong orbital bristles present, the orbital pubescence not very conspicuous; frontal triangle fairly well defined, reaching over three-fourths of the way to lunule; lunule shining, brownish, with indications of whitish pollinosity; antennæ small, black; dorsal bristle on second joint long; third joint not longer than broad, rounded at apex, pilosity pale, very short; arista thickened and tapering on basal fourth, pubescence distinct, slightly longer than basal diameter of arista, length of arista equal to from its base to upper orbital bristle; face short, black, concave in profile; cheek short, shining black, marginal bristles very numerous, strong, and irregularly arranged, not in a single row, carried upward beyond the level of the weakly differentiated vibrissa; proboscis yellow at apex; palpi black, numerous, bristled; occiput not produced. Mesonotum glossy blue-black, more inclining to brown-black on lateral margins; two distinct pairs of dorso-centrals present; disk covered with numerous short setulæ; no distinct bristles between the posterior dorso-centrals; pleuræ glossy blue-black, sutures and below wing base brown; squamæ white, fringe concolorous; scutellum concolorous with disk of mesonotum, the marginal bristles subequal. Abdomen ovate, bronzy blue-black; first two segments short, the others subequal, all segments with short discal setulæ, those on posterior margins of segments strong; base of ovipositor not longer than preceding segment. Legs strong, especially the femora, which are thickened; black, shining, tibiæ at base brownish; fore tibia with a strong bristle on posterior surface at below middle; the pair of bristles on posterior surface of mid tibia strong. Wings clear, veins brownish yellow; second costal division about twice as long as first; subcostal vein indistinct; outer cross vein at slightly below wing middle, and at a little more than its own length from margin to wing on fifth vein, and from inner cross vein; veins 2-3 divergent, 3-4 slightly convergent at apices; inner cross vein at below junction of first vein with costa, and at middle of discal cell. Halteres black, pedicel yellowish brown. Length 3-4 mm.

Type: Cat. No. 15584, U. S. N. M.

Locality: The specimen bears the M. S. label "S. J. Allende, Mexico," and the numbers 11-29, which probably means that it was taken on November 29. I cannot find on the available maps of Mexico any locality in accordance with that on the label. No collector's name is given. One specimen.

Food-plant unknown.

49. *Agromyza burgessi*, new species.

Plate XXXI, Fig. 34.

Female: Frons black; center stripe brown-black, opaque, orbits glossy black; breadth of frons distinctly, but not greatly, over one-third the width of head; breadth of each orbit about equal to one-fourth the width of center stripe; generally six strong orbital bristles present, in one specimen five only; the bristles situated on nearer to inner than outer margin of orbits; the space between eye margin and bristles thickly covered with short hairs; ocellar triangle poorly defined anteriorly, the gloss on surface not continuing to its apex; lunule whitish pollinose; frons projecting slightly anteriorly, giving the head a somewhat buccate appearance; eye orbit continued to almost hind angle of eye; glossy black; antennæ small, brown; third joint not longer than broad, regularly rounded at apex; arista swollen at base, bare, as long as from its base to between second and third uppermost orbital bristles; cheek brown, distinctly higher at posterior than at anterior margin, and at highest point distinctly over one-third the height of eye; marginal bristles of moderate strength, not numerous; vibrissa well differentiated; proboscis brown; palpi black, slightly spatulate, weakly bristled at apex; occiput distinctly visible on upper half. Mesonotum black, glossy, without any distinct bluish fringe; bristles as in *cærulea*; pleuræ brown-black, the sutures and below wing base pale brown; squamæ grayish, margin black-brown, the fringe brown; scutellum black, glossy, bristles subequal. Abdomen glossy black or brown-black, with, in some lights, a bronzy luster; second segment not so distinctly shortened as in *cærulea*; in other respects similar to that species. Legs similar to previous species, but the bristle on fore tibia is weaker. Wings in most respects similar to *cærulea*, but the third and fourth veins are distinctly divergent on their outer sections. Halteres brown.

Length 3.5-4 mm.

Type: Cat. No. 15585, U. S. N. M.

Locality: Beverly, Massachusetts, June 2, 1876 (Burgess).

Specimens of this species are in collection from Tower City, North Dakota, (G. I. Reeves), Webster's No. 3122, 2 females; and Colorado, No. 1563, no collector's name, 1 female. I have named this species in honor of the late Edward Burgess, who collected the type specimen 37 years ago. I have seen one specimen in C. W. Johnson's collection from Lancaster, New York, which has the bristles on fore tibia indistinguishable.

Food-plant unknown.

50. *Agromyza plumiseta*, new species.

Female: Frons black, center stripe opaque, orbits, ocellar region, and the well defined ocellar triangle glossy black; breadth of frons one-third the head width, ocellar triangle reaching three-fourths of the way to lunule, which is whitish pollinose; orbital bristles four in number, moderately strong; hairs on orbits numerous and irregularly arranged; each orbit one-fourth the width of center stripe; the bristles situated close to inner margin; antennæ of moderate size, deep black; third joint rounded in front, not as long as broad; second joint with distinct dorsal bristle; arista brown, swollen at base, pubescence very distinct, longer than basal diameter of arista, length of arista equal to from its base to upper orbital bristle; face black, concave, mouth margin slightly produced; cheek very short and low; marginal bristles rather weak, vibrissa well differentiated; proboscis yellow at apex; palpi black, slightly spatulate, and weakly bristled at tips; occiput not projecting. Mesonotum blue-black; two pairs of dorso-centrals present; setulæ numerous on disk, continued posteriorly beyond transverse line of posterior dorso-centrals; pleuræ black, shining, with a bluish sheen, the sutures, and below wing base brown; squamæ yellowish white, fringe concolorous; scutellum colored as disk of mesonotum, apical pair of bristles very slightly smaller than basal pair. Abdomen black, with a distinct, metallic blue sheen; basal segment brown; all segments with very numerous discal setulæ, those on apices of segments most distinct; sixth segment very slightly elongated; base of ovipositor not longer than preceding segment. Legs black, shining, strong; posterior surface of mid tibia with the pair of bristles distinct. Wings clear; veins brownish yellow; first costal division barely more than one-third as long as second; inner cross vein at below end of first vein and at middle of discal cell; outer cross vein at very slightly beyond wing middle, and at more than its own length from inner; veins 2-3-4 gradually divergent on their last sections; last section of fifth vein about two-thirds as long as penultimate section. Halteres black.

Length 2 mm.

Type: Cat. No. 15586, U. S. N. M.

Locality: Bayamon, Porto Rico, January, 1899, (A. Busck) Along with the type there is a male from Fajardo, Porto Rico, February, 1899 (A. Busck), which belongs here. It differs only in having the frons slightly less than one-third the head width and though in poor condition is evidently, in other respects, identical with the female.

Food-plant unknown.

51. *Agromyza websteri*, new species.

Male and Female: Frons deep black; center stripe opaque, orbits and ocellar triangle glossy; width of frons almost one-half that of head, narrower at anterior margin than posteriorly; width of each orbit about one-fourth that of center stripe; five orbital bristles generally present, but sometimes there are six in aberrant specimens; besides the bristles, which are situated on close to inner margin of orbit, there is an outer irregular row of short black hairs; antennæ of moderate size, black with sometimes whitish pollinosity; second joint with distinct dorsal bristles, and weak apical hairs; third joint rounded, distinctly shorter than broad, pilosity very short, whitish; arista with a distinct, elongate thickening at base, which occupies almost one-third the length of arista; pubescence very indistinct; length of arista equal to from its base to middle of orbit; face opaque black; concave in profile, the mouth margin slightly produced; cheek opaque black; of almost equal height on its entire length, which is equal to about one-fourth the eye height, marginal bristles in a double row, the upper slightly upturned, of moderate length; vibrissa distinctly differentiated; proboscis yellow-brown at apex; palpi black, slightly spatulate, weakly bristled. Mesonotum subshining black, with slight indications of grayish pollinosity, especially on sides; disk very thickly covered with short, upright, black setulæ; three pairs of dorso-centrals present, the anterior pair weak, and occasionally there are 2-3 setulæ in line with those, which are distinctly longer than the other discal setulæ, but which are clearly not macrochaetæ; no differentiated bristles between the posterior dorso-centrals; pleuræ black, subshining, sutures brownish; squamæ brown, or gray, the margin blackish, fringe black-brown; scutellum concolorous with disk of mesonotum. Abdomen shining black; broadly ovate; segments with distinct dorsal setulæ, those on posterior margins, and especially on sixth segment, in female, longer; sixth segment slightly elongated; base of ovipositor glossy black; male hypopygium small, shining black. Legs black, shining; femora strong; no bristles distinguishable on mid tibia in any of the specimens before me. Wings grayish; veins brown-black; first costal division distinctly more than one-half as long as second; subcostal vein distinct; fused with first at apex; inner cross vein below end of first vein; outer cross vein not upright, its upper extremity nearer to wing tip than its lower, situated at generally less than its own length from inner cross vein, and its upper extremity just before wing middle; veins 3-4 distinctly divergent at their apices; last section and penultimate section of fifth vein subequal. Halteres black.

Length 3.5-4 mm.

Type: Cat. No. 15587, U. S. N. M.

Locality: Seattle, Washington, issued January 21, 1913, from galls on twigs of pink wistaria from Japan, (F. M. Rhoder). Another specimen from same lot, in poor condition January

19, 1913 from same lot of galls. There are four specimens representing both sexes marked Ex. galls on pink wistaria, Japan, B. B. Whitney, No. 745.

This species has been recorded as *Agromyza schineri* Giraud,\* on the authority of Aldrich. *Schineri* was reared from poplar by Giraud in Europe,† and is a much smaller species. The description of Giraud's species is brief but does not permit of one identifying it with the Japanese species. I include this imported species in my paper because it evidently has every chance of becoming established in this country. One striking peculiarity of the specimens before me of this species is the amount of variation in the number of bristles on head, thorax and scutellum. In many cases the normal bristle is duplicated and the number on any one part is not so consistent as in the other species of *Agromyza*. The distance between the cross veins of the wing is also very variable. In the figure of the wing given in the California publication the costa is carried only to the third vein whereas in all my specimens it is continued to the fourth.

52. *Agromyza longiseta*, new species.

Plate XXXI, Fig. 30.

Female: Frons deep black; center stripe opaque; orbits, and ocellar region shining; ocellar triangle not defined; width of frons barely one-third that of head; orbits ill defined, each one not one-fifth as wide as center stripe; four strong orbital bristles present; only a few short hairs on orbits besides the bristles; frons unprojecting, but head somewhat buccate in profile; antennæ rather small, black; third joint regularly rounded in front, about as long as broad, covered with short pilosity; dorsal bristle on second joint distinct; arista very slightly, and shortly, swollen at base, distinctly pubescent, the pubescence as long as diameter of base of arista, length of arista as long as from its base to vertex; face opaque black, almost perpendicular in profile; cheek black, of almost equal height on its entire length, and not over one-sixth the height of eye, marginal bristles numerous and of moderate size, carried higher in front than level of the differentiated vibrissa; proboscis brown; palpi black, very slightly broadened at ends, and weakly bristled; occiput not projecting. Mesonotum glossy black, with a slight greenish or bluish tinge; two pairs of dorso-centrals present; squamæ very dark, the margin almost black, fringe blackish. Abdomen concolorous with mesonotum; the posterior margin of sixth segment with rather long bristles; base of ovipositor highly glossy, the surface

\*Bull. Cal. State Com. Hort., Vol. I, No. 10, p. 730, 1912.

†Verh. zool-bot. Ges. Wien., Vol. II, 1861, p. 484.

bare except apically on sides, as long as the elongate sixth segment. Legs shining black; the posterior bristles on mid tibia distinct. Wings grayish; veins black-brown; subcostal vein distinct, fused with first at its apex; outer cross vein at wing middle, and at its own length from inner cross vein; inner at distinctly beyond middle of discal cell; last section of fifth vein not two-thirds as long as penultimate section; veins 3-4 slightly divergent at apices. Halteres black.

Length 2 mm.

Type: Cat. No. 15588, U. S. N. M.

Locality: Frontera, Tabasco, Mexico, March, (C. H. T. Townsend). One female.

Food-plant unknown.

### 53. *Agromyza tiliæ* Couden.

Syn: *Agromyza tiliæ* Couden, Proc. Wash. Ent. Soc., Vol. IX, 1907, p. 34.

Female: This species is very similar to *A. websteri*, but differs as follows: The antennæ are smaller, the third joint being rather below the average size; the arista is not so distinctly thickened at the base, nor for such a long distance, the thickening tapering gradually; the mesonotum is shining black; with two pairs of dorso-centrals; the pleuræ, scutellum, and abdomen glossy black; the squamæ and legs are similar in color to *websteri*, but the mid tibiæ has the posterior bristles distinct, though small; and in size *tiliæ* averages less, 2-3 mm. The venation in both species is rather variable, but the outer cross vein is generally at less than its own length from the inner.

The type series which is in rather poor condition, was reared from the galls on twigs of lime trees. Locality: Jennings, Missouri, March-April, 1907, (Mrs. Hickey).

The twig in collection shows the galls arranged on the surface, independent of the position of the leaf buds, whereas in *websteri* the galls are apparently confined to the bases of the buds. There are two specimens in collection, one male Veitch, Virginia, June 9, 1912, (F. Knab), and one female, Delaware County, Pennsylvania, July 23, 1892 (no collector's name), the former at least of which belongs to this species.

### 54. *Agromyza schineri* Giraud.

Syn: *Agromyza schineri* Giraud, Verh. zool.-bot. Ges. Wien, Vol. II, 1861, p. 484.

Male and Female: This species is very similar to *tiliæ* but differs as follows: The frons is distinctly broader, being over one-third as wide as head; the orbits are broader, the ocellar triangle is broader and shorter than in *tiliæ*, the ocelli not forming an equilateral triangle as in that species, the distance between the posterior pair being distinctly greater than that between those and the anterior one; the

arista is comparatively shorter and more distinctly swollen in *schineri* than in *tilia*; and the posterior surface of mid tibia in *schineri* has no distinct bristles.

Length 2-2.5 mm.

Originally described from Europe.

Locality of specimens in U. S. National Museum collection: Toronto, Canada, (collection W. Brodie); I have seen two specimens reared from galls on Poplar by C. A. Frost, Framingham, Massachusetts, submitted by C. W. Johnson.

55. *Agromyza congregata*, new species.

Male: This species is very similar to *tilia*, but differs as follows: The orbital bristles are four in number, strong and equally spaced; the cheeks are comparatively higher, being at center rather more than one-third the height of eye; the marginal mouth bristles are strong, and form a group at the anterior angle of cheek, amongst which the vibrissa is hardly distinguishable; the entire color of insect is a deep black; the legs are strong and there is no trace of the posterior bristles on the mid tibia; the wing venation is similar to *tilia*.

Length 1.75 mm.

Type: Cat. No. 15589, U. S. N. M.

Locality: Williams, Arizona, May, (H. S. Barber), one male.

Food-plant unknown.

56. *Agromyza minima*, new species.

Male: Frons black, center stripe opaque, orbits and frontal triangle glossy; breadth of frons one-third that of head; orbits narrow, each not one-fourth as wide as center stripe; four rather weak orbital bristles present, the orbits with additional short hairs; face black, opaque, concave in profile, mouth margin produced; cheek black, short, highest at center, where it is about one-fourth as high as eye; marginal bristles of moderate strength, the vibrissa weakly differentiated; occiput not projecting; antennae of moderate size; third joint regularly rounded, distinctly shorter than broad; arista not much swollen at base, tapering, almost bare, its length equal to from its base to almost upper orbital bristle. Mesonotum glossy black, with a slight bluish tinge; two pairs of dorso-centrals present; pleurae concolorous with disk of mesonotum; squamae gray, margin and fringe brown. Abdomen glossy black, with a distinct metallic bluish tinge. Legs black; the posterior mid tibial bristles distinct, though small. Wings grayish; inner cross vein at slightly beyond end of first vein, and at slightly beyond middle of discal cell; outer cross vein at about its own length from inner, and at slightly beyond wing middle; last section of fifth vein barely more than one-half as long as penultimate section; veins 3-4 almost parallel on their last section.

Length slightly over 1 mm.



Type: Cat. No. 15590, U. S. N. M.

Locality: Trinidad, West Indies, June, (A. Busck).

Paratypes: Three females. Those are identical with the male in all essential characters. Localities: Mayaguez, Porto Rico, January, 1899 (A. Busck); Utica, Mississippi, August (no other data); and one specimen taken on flowers of *Bige-  
lovia graveolans*, Mescalero, Mexico, October 2, 1896 (T. D. A. Cockerell). Food-plant unknown.

Williston's description of *Agromyza anthrax*.

Trans. Ent. Soc. Lond. 1896, p. 430.

**"*Agromyza anthrax*, n. sp."**

"Male: Black, but little shining. Front very broad, nearly square, its width rather exceeding its length; opaque black, on its lower margin yellowish. Antennæ black, third joint rounded, large, pubescent, arista very short pubescent. Face receding, excavated, not at all visible from the sides; cheeks linear, with black bristles along the oral margin, and a rather stout vibrissal bristle in front. Palpi projecting beyond the oral margin, yellow. Mesonotum and scutellum a little shining. Abdomen opaque, oval. Halteres yellow. Knees and tarsi yellow, the distal joints of the latter brownish. Wings lightly tinged; the third vein terminates in the apex of the wing; penultimate section of fourth vein about one-third as long as the ultimate section of fifth."

"Length  $1\frac{1}{2}$  mm."

"One specimen, St. Vincent."

Owing to the omission to mention the number of dorso-central bristles in this species, and some other essential characters, I cannot place this species in my synoptic table, but in general appearance it must approach very closely to *varifrons* Coquillett.

Williston's description of *Agromyza innominata*.

Trans. Ent. Soc. Lond. 1896, p. 443.

**"*Agromyza innominata*, n. sp."**

"Male: Head yellow, a blackish spot at the ocelli; front broad. Antennæ yellow; third joint longer than broad; arista finely pubescent. Face short, gently excavated in profile; cheeks rather broad. Palpi elongate, dilated. Thorax obscurely reddish yellow; mesonotum with black hairs. Scutellum large, with two stout, remote, black bristles. Abdomen brown or blackish, yellowish at base. Legs light yellow; hind femora black at the immediate tip. Wings cinereous hyaline; basal cells complete; penultimate section of fourth vein a little longer than the posterior."

"Length  $1\frac{1}{4}$  mm."

"One specimen."

"Locality: St. Vincent, West Indies."

I have not seen this species, and cannot place it in my synoptic table from the characters given in the description. No species of *Agromyza* that I have seen has only two scutellar bristles, and the palpi are remarkably large for a species of this genus. The head, with the exception of the palpi, as figured, looks like an *Agromyza*, but the arista is rather strongly pubescent, for most of the species in that genus. I suspect that it does not belong here, and the head figured on page 292 in Williston's Manual, which is quite evidently a reproduction of his figure 158 on Plate 14 of the original publication of the description, being given as "*Agromyza* (nov. gen.?)" in the Manual, would seem to indicate that Williston also thought so in 1903, whatever he may have thought in 1896. No indication is given as to the specific identity of the species, or source from which figure came in the Manual.

Lundbeck's description of *Agromyza arctica*.

Vidensk. Meddel. Copenhagen, 1899, p. 304.

"148. *A. arctica* n. sp. Fig. 4."

"*Brunneocinerea*, thorace opaco, abdomine subnitido, lateribus thoracis maculis flavis ornatis, lateribus abdominis flavis, segmentis abdominis margine posteriore anguste flavescente. Fronte sordide flava, lunula supra antennis flava; antennis flavis, basi et margine exteriore articuli tertii brunnescentibus, arista nigra. Epistomate flavo. Alis hyalinis, leviter flavescentibus, nervo longitudinali quarto in apice alæ excurrente, costa ad apicem nervi longitudinali quarti producta. Halteribus flavis. Pedibus cinerascentibus, geniculiset lateribus inferioribus femorum flavis. ♂ ♀. Long. 2 mm.

"*A. geniculatæ* affinis. Mas. *Brunneocinereus*, thorax opacus, abdomen subnitidum, thorax longe sed parce pilosus, abdomen brevius pilosum, scutellum in margine posteriore quattuor setis longis instructum; latera thoracis dilute cinerea, maculis flavis ornata, latera abdominis tota flava, margines posteriores segmentorum anguste flavescentes (saepe obsolete), metanotum sub scutellum linea flava ornatum. Frons sordide flava, supra antennis lunula flava. Antennæ flavæ, basi et margine dorsali articuli tertii brunnescentibus, arista nigra. Epistoma flavum, occiput brunneogriseum. Alæ hyalinae, leviter flavescentes, nervus longitudinalis secundus et tertius leviter arcuati, ad apicem reflexi, nervus longitudinalis quartus rectus, in apicem alæ excurrere, costa ad apicem nervi longitudinali quarti producta, nerve transversali appropinquati, posterior ante mediam alam situs. Halteres flavi. Pedes cinerei, geniculis et femorum lateribus inferioribus flavis sive refuscentibus. Fem. Mari similis, abdomen ovipositore conico, nigrobrunneo, valde nitido, daubus lamellis nigris, parvis terminato."

"*Individua plures adsunt colore toto et præsertim abdominis dilutiore versimiliter immatura.*"

"Synes at forekomme temmelig almindelig langs hele Vestkysten idet mindste op til 69° N. Br.; træffes især i Pilekrattet, Larven lever maaske i Pileblade. Igaliko-Fjord, Tunugdliarfikfjord, Tassiusak Kristianshaab, Sydstøbtugten (Forf.).

This species bears a resemblance to *borealis* described on a previous page, the venation being almost identical in Lundbeck's figure with that given in this paper for *borealis*, but his description is lacking in several essentials, so that it is not possible to say definitely whether the species are really the same or not.

#### *Cerodontha Rondani.*

Syn: *Cerodontha Rondani*, Dipt. Ital. prod. Vol. IV, 1861, p. 10.

*Odontocera* Macquart, Suit a Buffon, Vol. II, 1835, p. 615 (Preocc.).

*Ceratomyza* Schiner, Wien. entom. Monatschr. Vol. VI, 1862, p. 434.

#### Characters of the Genus.

Similar in most respects to *Agromyza*, but the third antennal joint terminates, on the upper surface, in a thorn-like point. The frontal and thoracic bristling is similar in nature to that of *Agromyza*, but in no case have I seen more than two scutellar bristles on the species I have examined; nor do I know of any species in which more than two are present. The mid tibia has no posterior bristles, and the costa always reaches to the fourth vein.

#### *Cerodontha dorsalis* Loew.

Plate XXXI, Figs. 33, 39.

Syn: *Odontocera dorsalis* Loew, Dipt. Amer. Sept., Indig., Cent. 1, 1861, species 99.

Male and Female: Frons yellow, opaque, in breadth about one-half that of head; orbits sometimes blackened, very narrow, on upper half each not over one-sixth as wide as center stripe; three distinct orbital bristles present, and on lower portions a few short hairs; proclinate ocellar bristles parallel, or slightly divergent, separated at base by as wide a space as posterior ocelli; antennæ yellow, third joint black, one and one-half times as long as broad, ending in a thorn-like point on upper side; arista black, distinctly thickened at base and tapering to near its middle, pubescence indistinguishable, length of arista short of twice the length of antennæ; face yellow, slightly concave, central keel rounded; cheeks yellow, higher posteriorly than anteriorly, and at highest point about one-half as high as eye, marginal bristles distinct; vibrissa strong, differentiated from marginal bristles; proboscis and palpi yellow; occiput unprojecting on upper half. Mesonotum with disk entirely glossy black, with sometimes an indication of grayish

pollen, or with the central portion in front of scutellum yellow, more rarely with two narrow black stripes on sides, and the central yellow portion carried forward at its anterior margin, slightly beyond middle, as narrow lines which more or less distinctly intersect the broad discal black mark, giving the disk the appearance of having five stripes, or a pattern somewhat similar to that of *Agromyza melampyga*; lateral margins of mesonotum broadly yellow; humeri with a black spot; four pairs of dorso-central bristles on mesonotum; no setulæ on disk; pleuræ yellow with black variegations; squamæ yellow, the fringe brownish or grayish; scutellum all black or with the disk yellow, two scutellar bristles present. Abdomen from almost entirely yellow to almost entirely black, posterior margins of segments narrowly yellow. Legs slender, yellow, sometimes with fore tibiæ and tarsi blackened, all tarsi brownish. Wings as figure.

Length 2-2.5 mm.

The following is a list of the States from which I have seen specimens: Connecticut, Massachusetts, Iowa, Florida, Georgia, District of Columbia, Kentucky, Indiana, Nevada, New Mexico, Texas, Utah, Washington, Tennessee, Nebraska, Michigan, Illinois and California.

I have also seen specimens from Mexico and Porto Rico. The larva mines the stems of grains and grasses.

#### ADDENDA.

##### *Agromyza quadrisetosa*, new species.

Female: Back subshining. Head yellow, ocellar spot, upper third of orbits, back of head, 3rd antennal joint, palpi and upper mouth margin black. Mesonotum with lateral margins broadly pale, whitish yellow, humeri with a black spot; pleuræ with upper margin concolorous with margin of mesonotum; scutellum yellow, margined on sides with black, squamæ yellow. Abdomen black, glossy, the segments with narrow, yellow, posterior margins. Legs entirely shining black. Wings clear, basal portion of veins pale yellow, outer portions brownish. Halteres yellow.

Frons about one and one-third times as long as broad at vertex; orbits glossy, six orbital bristles present, incurved, situated on middle of orbit and of good length; orbits otherwise bare; antennæ of moderate size, third joint rounded, second joint with dorsal bristle distinct; arista tapering, bare, brown in color, equal in length to from its base to second uppermost orbital bristle; cheeks at anterior margin about equal in height to breadth of third antennal joint, at posterior margin equal to slightly more than half of the height of the eye. Mesonotum with 4 pairs of dorso-centrals, between which are 2-3 irregular rows of setulæ which do not extend to posterior dorso-centrals; scutellar bristles (4) subequal. Abdomen with apices of all segments armed with rather strong bristle-like hairs. Legs with mid tibial posterior bristles absent or very weak. Wings with costa to fourth vein; veins 3-4

divergent; outer cross vein at less than its own length from inner and but little beyond end of first vein; last section of fifth vein twice as long as penultimate section.

Length 2 mm.

Type: Cat. No. 15957, U. S. N. M.

Type locality: San Antonio, Texas, April 8, 1907 (F. C. Pratt). Nothing recorded of early stages.

This species belongs to the *pusilla* group, but may readily be separated from any of those in this paper by the black palpi, third antennal joint and legs. It is distinct from any of the European species I have examined.

*Agromyza melampyga* Loew.

This species has been bred by C. R. Jones at San Antonio, Texas, from root of *Plantago media*.

*Agromyza citreifrons* Malloch.

I had some doubt as to the distinction of this species from *hilarella* Zetterstedt, but I have since examined specimens belonging to the National Museum in Budapest, and consider them quite distinct. *Hilarella* has the frons darker than *citreifrons*, the antennæ darkened on upper surface of third joint, the face less receding, the eyes longer than high, the wings narrower, the inner cross vein distinctly before middle of discal cell, and the last section of fifth vein very distinctly longer than the penultimate section.

*Agromyza longipennis* Loew.

I have examined specimens from Europe, of *geniculata* since writing the above, and find they are distinct from *longipennis* in having the legs less broadly yellow on joints, the arista almost bare, as against the distinct pubescence of *longipennis*, and the last section of fifth vein distinctly shorter than penultimate section.

*Agromyza angulata* Loew.

Two specimens submitted as *luctuosa* Meigen from Budapest represent two distinct species, one of which is very close to *angulata* Loew. Under the circumstances I consider that it is not desirable to question the retention of *angulata* as the name for the American species.

*Agromyza abnormalis* Malloch.

This species differs from *obscuritarsis* Rondani in being more robust, darker in color throughout, and particularly in that the frons and halteres, and in neuration, the last section of fifth vein in *obscuritarsis* being about one and one-half times as long as penultimate section. Both species have 4 pairs of dorso-centrals.

*Agromyza kincaidi* Malloch.

On comparison of the type of this species with specimens submitted from Budapest museum as *nigripes*, I find that the European form has over all a more glossy black color, the frons is much narrower, being barely wider than width of either eye, and narrowed anteriorly, the arista is almost bare, the squamae are darker, with brown fringes, and the last section of fifth vein is almost as long as the penultimate section.

An example from Hampton, N. H. (S. A. Shaw) agrees in almost every particular with those from Europe so that this species may be added to the American list and the name changed to *subnigripes* n. nom. for the reasons stated in this paper.

*Agromyza pruinosa* Coquillett.

This species has been reared from larvae mining under bark on birch trees by C. T. Green of the Division of Forest Insects, at Falls Church, Va. I have examined two males which agree in every particular with the type, except in being rather larger.

*Agromyza caerulea* Malloch.

I have examined a series of 8 specimens reared from *Ipomoea sinuata* and 5 from *Ipomoea lacunosa*, at Victoria, Texas, in September, 1907, and 7 from same locality August, 1907, labelled *Ipomoea*, by J. D. Mitchell. They agree with the Mexican specimen in all particulars.

*Agromyza texana* Malloch.

Two pairs taken in copula at Kerrville, Texas, June 19, 1907 (F. C. Pratt).

## INDEX TO GENERA AND SPECIES.

*Names in italics are synonyms.*

	PAGE		PAGE
abbreviata (Agromyza).....	285	maculosa (Agromyza).....	302
abnormalis ( " ).....	320, 334	<i>magnicornis</i> ( " ).....	300
affinis ( " ).....	317	<i>malvæ</i> (Oscinis).....	293
Agromyza.....	270	marginalis var (Agromyza	
<i>amæna</i> (Agromyza).....	278	<i>melampyga</i> ).....	283
angulata ( " ).....	304	marginata (Agromyza).....	298
anthrax ( " ).....	329	melampyga ( " ).....	282, 333
arctica ( " ).....	330	minima ( " ).....	328
<i>bicornis</i> ( " ).....	318	neptis ( " ).....	309
<i>blanda</i> ( " ).....	278	nigripes ( " ).....	286
borealis ( " ).....	280	nitida ( " ).....	288
<i>brassicæ</i> (Oscinis).....	278	Odinia.....	289
brevicostalis (Agromyza).....	283	<i>Odontocera</i> .....	331
" ( " ).....	323	<i>orbona</i> (Agromyza).....	278
burgessi ( " ).....	322	ornata (Odinia).....	290
cærulea ( " ).....	322	parvicella (Agromyza).....	287
canadensis ( " ).....	299	parvicornis( " ).....	312
capitata ( " ).....	297	Phytomyza.....	278
<i>Ceratomyza</i> .....	331	<i>picta</i> (Agromyza).....	275
Cerodontha.....	331	<i>pictella</i> ( " ).....	280
<i>citrefrons</i> (Agromyza).....	290, 333	platyptera ( " ).....	293
<i>coloradensis</i> ( " ).....	295	plumiseta ( " ).....	324
<i>congregata</i> ( " ).....	328	posticata ( " ).....	308
<i>coquelletti</i> ( " ).....	297	pruinosa ( " ).....	291
<i>coronata</i> ( " ).....	293	<i>puella</i> ( " ).....	278
<i>curvifaplis</i> ( " ).....	318	pusilla ( " ).....	278
<i>davisi</i> ( " ).....	284	<i>pusio</i> ( " ).....	278
<i>diminuta</i> (Phyllomyza).....	278	quadrisetosa ( " ).....	332
<i>discalis</i> (Agromyza).....	277	salicis ( " ).....	314
<i>Domomyza</i> .....	286	schineri ( " ).....	327
<i>dorsalis</i> (Cerodontha).....	331	scutellata ( " ).....	280
<i>dubitata</i> (Agromyza).....	311	setosa ( " ).....	305
<i>exilis</i> ( " ).....	278	simplex ( " ).....	315
<i>flaveola</i> ( " ).....	280	<i>sorosis</i> ( " ).....	282
<i>flaviventris</i> ( " ).....	282	<i>strigata</i> ( " ).....	278
<i>flavonigra</i> ( " ).....	281	subnigripes ( " ).....	334
<i>fragariæ</i> ( " ).....	307	<i>tæniola</i> ( " ).....	308
<i>geniculata</i> ( " ).....	333	<i>terminalis</i> ( " ).....	308
<i>grossicornis</i> ( " ).....	300	texana ( " ).....	319, 334
<i>immaculata</i> ( " ).....	289	tiliæ ( " ).....	327
<i>inconspicua</i> ( " ).....	310	<i>trifolii</i> (Oscinis).....	278
<i>indecisa</i> ( " ).....	292	variata (Agromyza).....	277
<i>innominata</i> ( " ).....	329	<i>varifrons</i> ( " ).....	292
<i>insularis</i> ( " ).....	318	<i>vibrissata</i> ( " ).....	316
<i>isolata</i> ( " ).....	306	<i>virens</i> ( " ).....	321
<i>jucunda</i> ( " ).....	293	<i>viridula</i> ( " ).....	313
<i>kincaidi</i> ( " ).....	285	<i>waltoni</i> ( " ).....	303
<i>lateralis</i> ( " ).....	293	<i>websteri</i> ( " ).....	325
<i>laterella</i> ( " ).....	300	<i>winnemannæ</i> ( " ).....	314
<i>longipennis</i> ( " ).....	296, 333	<i>xanthocephala</i> ( " ).....	297
<i>longispinosa</i> ( " ).....	276	<i>xanthophora</i> ( " ).....	275
<i>longiseta</i> ( " ).....	326		

## LIST OF FIGURES.

## PLATE XXVIII.

- Fig. 1. Wing of *A. nitida*.  
 Fig. 2. " " *vibrissata*.  
 Fig. 3. " " *immaculata*.  
 Fig. 4. " " *parvicella*.  
 Fig. 5. " " *fragariæ*.  
 Fig. 6. " " *waltoni*.  
 Fig. 7. " " *davisi*.  
 Fig. 8. " " *brevicostalis*.

## PLATE XXIX.

- Fig. 9. Wing of *A. abnormalis*.  
 Fig. 10. " " *borealis*.  
 Fig. 11. " " *parvicornis*.  
 Fig. 12. " " *kincaidi*.  
 Fig. 13. " " *cærulea*.  
 Fig. 14. " " *variata*.  
 Fig. 15. " " *salicis*.  
 Fig. 16. " " *angulata*.

## PLATE XXX.

- Fig. 17. Head of *A. parvicella*.  
 Fig. 18. " " *angulata*.  
 Fig. 19. " " *canadensis*.  
 Fig. 20. " " *melampyga*.  
 Fig. 21. " " *discalis*.  
 Fig. 22. " " *longispinosa*.  
 Fig. 23. " " *borealis*.  
 Fig. 24. " " *vibrissata*, male.  
 Fig. 25. " " " female.  
 Fig. 26. " " *nitida*.  
 Fig. 27. " " *flavonigra*.  
 Fig. 28. " " *coquilletti*.

## PLATE XXXI.

- Fig. 29. Hypopygium of *A. posticata*, male.  
 Fig. 30. Head of *A. longiseta*.  
 Fig. 31. Mesonotum of *A. melampyga*.  
 Fig. 32. Wing of *A. abbreviata*.  
 Fig. 33. Wing of *Cerodontha dorsalis*.  
 Fig. 34. Head of *A. burgessi*.  
 Fig. 35. Hypopygium of *A. parvicornis*, male.  
 Fig. 36. Head of *A. waltoni*.  
 Fig. 37. " " *parvicornis*.  
 Fig. 38. " " *insularis*.  
 Fig. 39. " " *Cerodontha dorsalis*.

The Plates were drawn by W. R. Walton, with the exception of Figures 14, 15, 30, 34, and 38, which are by the author.



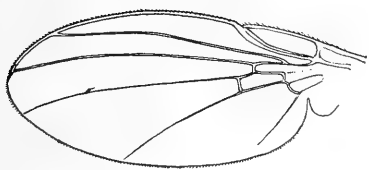

1

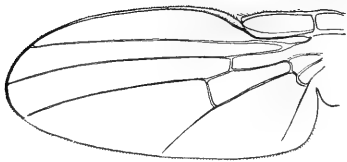

2

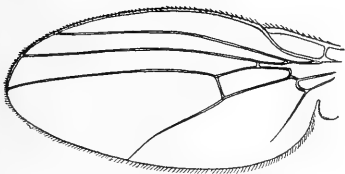

3

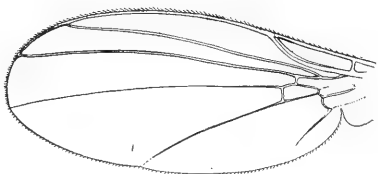

4

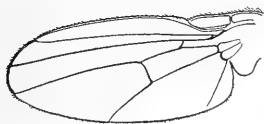

5

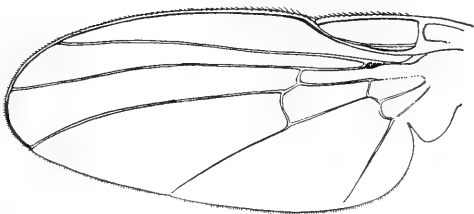

6

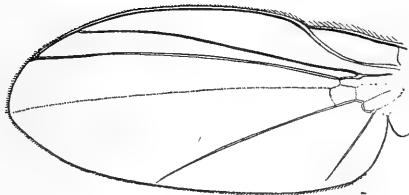

7

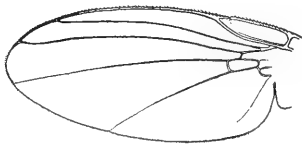

8

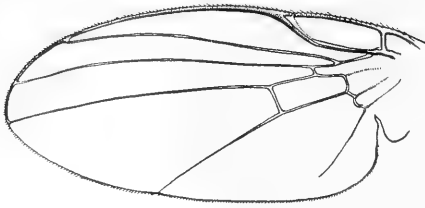

9

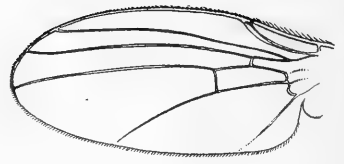

10

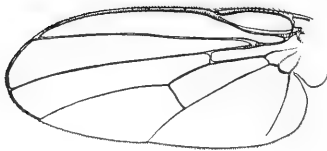

11

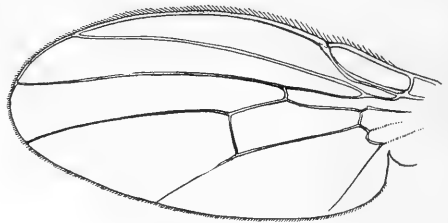

12

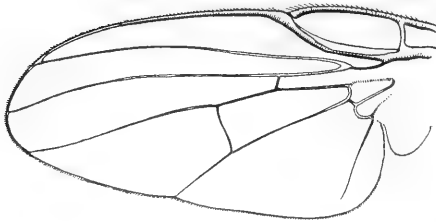

13

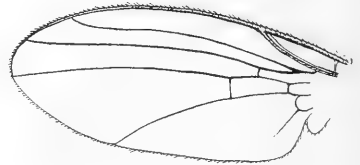

14

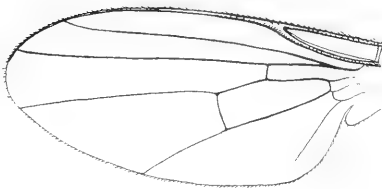

15

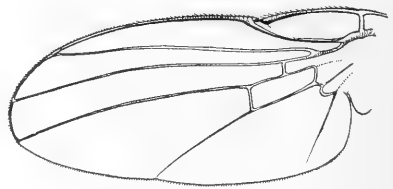

16

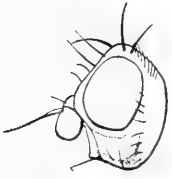

17



18

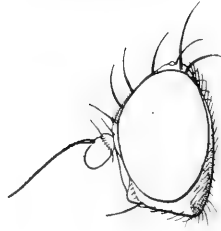

19

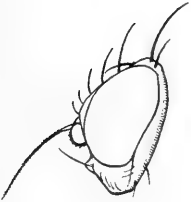

20



21



22



23



24



26

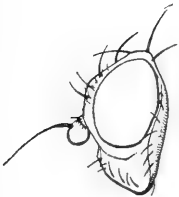

27



25

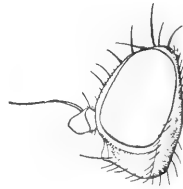

28

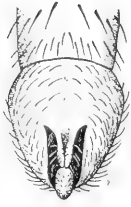

29



30



31

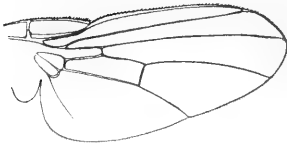

32

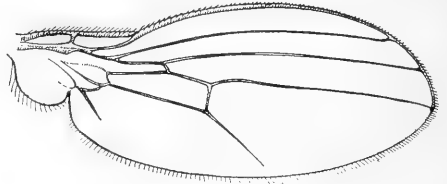

33

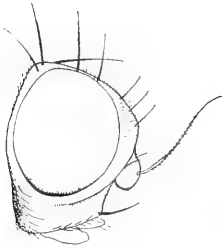

34



35

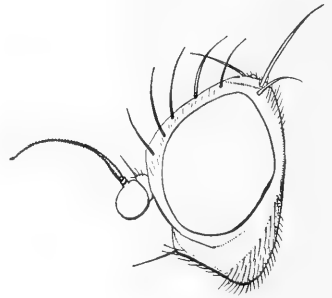

36

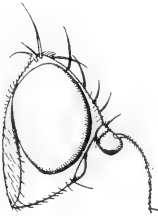

37



38

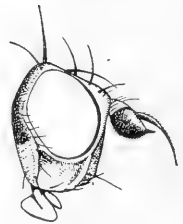

39

## THE WING VENATION OF THE FULGORIDÆ.

Z. P. METCALF.

The present paper is a continuation of my work on the homologies of the wing veins of Homopterous insects, a paper having previously been published on the wing venation of the Jassidæ.\*

The present paper is based upon a study of the wing pads of eleven genera of Fulgoridæ. These eleven genera are distributed among seven of the eleven commonly recognized sub-families of Fulgoridæ. Two of the sub-families not represented in this study are not found in our territory and I have not been able to secure representatives of the two remaining sub-families, *Achilida* and *Fulgorida*. The venation of these two sub-families presents no special difficulties when viewed in the light of our knowledge of other Fulgoridæ which have been carefully studied.

The same technique has been used in preparing the material for studying the wing venation of the Fulgoridæ that was used for studying the Jassidæ. The nymphal wings being removed as carefully as possible were mounted in water. The wing pad was then either drawn with the aid of a camera lucida or a photomicrograph made. Afterward a pen and ink drawing was made from the photomicrograph uniform with the camera lucida drawings. The drawings of the adult wings were made from balsam mounts with the aid of the Edinger drawing apparatus. The magnifications used in both cases varied greatly being adapted as far as possible to the needs of individual cases.

The relation of the main tracheæ of the wing pads to the body tracheæ is an interesting one and one upon which much stress has been laid in the past. The relationships of the main tracheæ of the wing pads can be much better understood if they can be traced back to their origin from the main body tracheæ.

Unfortunately, however, the wing pads of most insects are so placed that the body tracheæ lie very deep. This makes it practically impossible to secure the body tracheæ by the

---

\*ANNALS of the Entomological Society of America, Vol. VI, No. 1.

ordinary methods of dissection. If the wing is carefully removed, however, the relationships of the main tracheæ need not be disturbed. Some emphasis has also been placed on the fact that in some families the tracheæ of the wing pads arise from a single basal trachea, whereas in certain other families the radio-medial group of tracheæ arises from a cephalic body trachea while the cubito-anal group arises from a caudal body trachea. In certain cases this character has been used to indicate that one family is more primitive structurally than another. That such a position is untenable is clearly shown in at least two genera of the Fulgoridæ in which I was so fortunate as to secure enough of the body tracheæ as to determine this point. In *Thionia* (Figs. 27, 28) the tracheæ of the fore wing pad arise from a single body trachea while the tracheæ of the hind wing pad arise from a cephalic and a caudal body trachea. In *Amphiscepa* (Figs. 5, 6), on the other hand, the tracheæ of the fore wing arise from two body tracheæ whereas the tracheæ of the hind wing arise from a single body trachea.

#### THE FORE WING.

Unlike the fore wings of the Jassidæ, the fore wings of the Fulgoridæ are exceedingly variable. As is well known, the adults of many Fulgoridæ occur in two forms, a long-winged or *macropterous form*, and a short-winged or *brachypterous form*. This is especially true of certain genera. While the problem of the origin and significance of this variation is an exceedingly interesting one, it has not been taken into consideration in this paper, and as a rule, only *macropterous forms* have been considered with the exception of a few cases where the *brachypterous forms* are the usual ones.

The wings of the Fulgoridæ show two marked forms of specialization from the hypothetical type, the one by the addition of accessory branches to the main veins and the other by the reduction of the number of branches of the main veins. The one may be known as specialization by addition, and the other as specialization by reduction. An almost perfect series can be traced from the one extreme to the other. Forms like *Ormenis* (Fig. 13), show as great specialization by addition as is found in any insect of any order, while forms like *Bruchomorpha* (Fig. 33), show a great deal of specialization by re-

duction. While the wing venation of most of the insects that have been studied extensively so far can be reduced to a more or less uniform type for the family, in the Fulgoridæ no such typical form can be given. In the following discussion of the individual tracheæ the differences in the characters of the same trachea in different genera will not be emphasized so much as their resemblances.

#### *The Costa of the Fore Wing.*

The costa of the fore wing is usually present in the Fulgoridæ, in fact it was found in practically every genus studied. Typically, costa is a single unbranched trachea usually of somewhat less extent than subcosta. In *Ormenis* (Fig. 3), however, there are many small lateral tracheæ formed along the entire length of the costal trachea, and in *Amphiscepa* (Fig 5), the tip of the costal trachea breaks up into several smaller tracheæ. In *Thionia* (Fig. 27), the costal trachea shows a strong lateral branch near its base. This branch runs parallel with the main branch of costa and seems to be included in the same forming vein.

#### *The Subcosta of the Fore Wing.*

The subcosta has been found present in all of the genera studied. In many of the genera subcosta is a larger and more important trachea than radius. In nearly all cases it lies parallel with radius for the greater part of its length, while in *Scolops* (Fig. 23), it lies parallel with radius for its entire length. Subcosta is typically two branched in the *Delphacida* (Figs. 43, 45), and in the *Cixiida* (Fig. 47), while in *Amphiscepa* (Fig. 5), and *Ormenis* (Fig. 3), the tip of the subcosta breaks up into several small tracheæ.

#### *The Radius of the Fore Wing.*

Radius in the Fulgoridæ occupies a much less important position than in the wings of most other insects which have been studied in detail up to the present time. In most cases the radial trachea lies parallel with the subcostal trachea and usually only a single vein is formed in the region occupied by these two tracheæ. In *Stobæra* (Fig. 45), radius is a single unbranched trachea lying parallel with subcosta for more than half of its length then diverging and running parallel with one of the branches of medius for a short distance it

diverges toward the costal border. Radius occupies a somewhat similar position in *Myndus* (Fig. 47), except that there are three or four small branches near the tip and the trachea does not coalesce with medius in any part of its course. The condition of the radial trachea in *Dictyophara* (Fig. 25), is almost identical with that in *Myndus*, except that there are small lateral branches toward the tip. In *Thionia* (Fig. 27) and *Scolops* (Fig. 23), the radial trachea is quite similar in appearance to that in the genera discussed above except that separate veins are formed along these two trachea in *Thionia*. In both of these genera the lateral branches near the tip are much weaker and more uncertain in their position and are not the fore-runners of typical and fairly constant longitudinal veins, but of rather uncertain cross veins which are fairly common in these genera. In *Amphiscepa* (Fig. 5), and *Acanalonia* (Fig. 1) radius is a single unbranched trachea. In *Ormenis* (Fig. 3), the radial trachea consists of two main tracheæ which separate into several smaller branches before reaching the tip.

#### *The Medius of the Fore Wing.*

In all the genera studied the medial trachea is the most important trachea of the fore wing and its branches occupy more area than the branches of any other trachea. In the genera studied medius seems to be typically four branched only in *Amphiscepa* (Fig. 5). Each one of these branches, however, branches one or more times before reaching the tip of the wing. In *Ormenis* (Fig. 3), medius divides into two branches each branch again dividing into two branches. Each of these branches, however, is several times divided before reaching the tip of the wing pad. In *Acanalonia* (Fig. 1), medius is three branched, these branches representing medius one, medius two and medius three plus four. In *Scolops* (Fig. 23), *Dictyophara* (Fig. 25) and *Thionia* (Fig. 27), medius is typically two branched, although these branches may divide one or more times before reaching the tip of the wing pad. The veins which form along these secondary branches are not at all constant in position and relative importance. In *Stobæra* (Fig. 45), medius divides into two main branches. These branches represent medius one plus two and medius three plus four, medius one and medius two separating before reach-



ing the tip of the wing pad. In *Myndus* (Fig. 47), medius is typically four branched with an accessory branch between medius one and medius two.

*The Cubitus and the First Anal of the Fore Wing.*

As in the Jassidæ the cubital-first anal group forms the most characteristic land-mark in the tracheation of the Fulgoridæ. These two trachea are united for a short distance from the body trachea and cubitus is usually two branched. In *Thionia* (Fig. 27), *Dictyophara* (Fig. 25) and *Acanalonia* (Fig. 1), cubitus is unbranched, while in *Phylloscelis* (Fig. 7), cubitus is two branched and in *Stobæra* (Fig. 45), there is an accessory branch between cubitus one and cubitus two.

*The Second and Third Anal of the Fore Wing.*

The second anal trachea is a simple unbranched trachea and usually lies parallel with the first anal trachea. The third anal trachea is nearly always present in Fulgoridæ and is usually two branched. The second branch when present usually forms the anal border of the fore wing.

THE HIND WING.

The hind wing of the Fulgoridæ is almost as variable as the fore wing, very little similarity being observed in the different genera of some of the sub-families. Quite a little variation is frequently observed in different individuals of the same species.

*The Costa of the Hind Wing.*

The costal trachea is present in the following widely separated genera: *Myndus* (Fig. 48), *Scolops* (Fig. 24), *Dictyophara* (Fig. 26), *Thionia* (Fig. 28), *Acanalonia* (Fig. 2), and *Phylloscelis* (Fig. 8). In *Thionia*, *Phylloscelis* and *Myndus* it is united with subcosta for some distance from the body trachea. In *Scolops* it is present only as a weak trachea at the base of the wing.

*The Subcosta of the Hind Wing.*

The subcostal trachea was found in all the wing pads studied. In most of the genera it runs parallel with radius for almost its entire length and diverges at the tip. The radial and subcostal tracheæ are included in a common vein

except at the tip where subcosta diverges and the vein which forms along this tip in the adult resembles a branch of the radial vein. This condition is especially apparent in *Stobæra* (Fig. 46), *Myndus* (Fig. 48), *Dictyophara* (Fig. 26) and *Amphiscepa* (Fig. 6). In *Scolops* (Fig. 24), subcosta appears merely as a weak trachea lying parallel with radius along its base.

#### *The Radius of the Hind Wing.*

In nearly all cases radius of the hind wing is a single unbranched trachea. In certain genera, however, such as *Scolops* (Fig. 24), *Dictyophara* (Fig. 26) and *Acanalonia* (Fig. 2), radius shows more or less tendency to branch near the tip. These branches are rather variable as an examination of different individuals of the same species clearly shows. Therefore I have made no attempt to homologize these branches.

#### *The Medius of the Hind Wing.*

A typical medius of the hind wing of Fulgoridæ is two branched, but frequently these branches show a decided tendency to branch again before reaching the tip of the wing pad. In *Stobæra* (Fig. 46) and *Thionia* (Fig. 28) medius is a simple unbranched trachea which in *Stobæra* runs parallel with cubitus for a considerable distance, the veins of the adult coalescing at this point.

#### *The Cubitus of the Hind Wing.*

In many genera cubitus of the hind wing occupies the greatest area and bears somewhat the same relationship to the other tracheæ of the hind wing that medius bears to the other tracheæ of the fore wing. In *Myndus* (Fig. 48) and *Phylloscelis* (Fig. 8), cubitus is unbranched. In *Stobæra* (Fig. 46), *Thionia* (Fig. 28) and *Scolops* (Fig. 24) cubitus is typical. In the other genera studied cubitus has two principal branches, each of which bears one or more accessory branches.

#### *The Anals of the Hind Wing.*

The first anal of the hind wing bears the same relation to cubitus that it does in the fore wing. The second anal trachea is usually simple and unbranched, and lies parallel with the first anal. The third anal trachea has been found in all of the genera studied and is usually branched. Although in some cases *Thionia*, *Dictyophara* and *Scolops* the third anal trachea is three branched.

## SUMMARY.

Owing to the fact that the adult wings of the *Fulgoridæ* vary so much it has seemed best to summarize the homologies of adult wing veins by giving a discussion of the characters of the adult wings of the various subfamilies.

Sub-family **Fulgorida**.

Both the fore and hind wings of this sub-family are characterized by a large amount of reticulation. Nearly all the members of this sub-family are characterized by having a large number of accessory veins. These accessory veins may be added to radius, medius or cubitus, but in some cases, as in *Poiocera* (Fig. 9) all three of these veins bear accessory veins. In the hind wing radius and medius do not usually bear many accessory veins, but cubitus usually has several accessory veins. Another characteristic of the hind wings is the fact that the cross veins are apt to be connected together forming false veins between the principal veins. These false veins usually lie along the folds of the wing.

Sub-family **Flatida**.

The chief characteristics of this sub-family are: First, that the costal vein is remote from the costal border of the wing and connected with it by means of a number of cross veins; second, that radius and medius are provided with a large number of accessory veins; and third, that these accessory veins are usually connected by a definite series of cross veins at a uniform distance from the apical border of the wing. The hind wing is chiefly characterized by the great development of the anal area of the wing, and by a large number of accessory veins attached to cubitus.

Sub-family **Acanaloniida**.

The fore wings of the members of this sub-family are characterized by having a large number of cross veins between the branches of the principal veins. They are also characterized by having radius simple and unbranched, and the larger area of the wing occupied by the branches of the medius. In some cases, *Amphiscepa* (Fig. 15), medius is typically four branched with the addition of accessory veins to some of the branches. In other cases, *Acanalonia* (Fig. 17), medius is three branched,

the branches representing medius one, medius two and medius three plus four. The hind wing is characterized by the great development of cubitus, and the fact that in certain cases, *Amphiscepa* (Fig. 16), radius and medius coalesce for a considerable distance from the base of the wing.

#### Sub-family **Achilida.**

The fore wings in this sub-family are characterized by the fact that subcosta and radius are coalesced for a considerable distance from the base, and the fact that there are usually several cross veins between subcosta and the costal border of the wing. Radius and medius offer no special characters and cubitus is typically two branched, although there are frequently accessory cross veins between cubitus two and the anal border of the wing.

#### Sub-family **Dictyopharida.**

The chief characteristics of this sub-family are to be found in the complete or all but complete coalescence of subcosta and radius. In *Scolops* (Fig. 29), they are completely coalesced. In *Dictyophara* (Fig. 31), nearly completely coalesced, but in *Phylloscelis* (Fig. 22), are not coalesced except for a short distance at the base. Medius is typically two branched, but in *Scolops* (Fig. 29), there are several accessory branches. In *Scolops* (Fig. 29), and *Dictyophara* (Fig. 31), cubitus is typically two branched, but in *Phylloscelis* (Fig. 22), cubitus bears several accessory branches.

#### Sub-family **Issida.**

I have studied only a few genera in this sub-family. In *Thionia* (Fig. 35), all of the branches of the principal veins are reduced, medius alone being typically two branched. All of the veins are connected by a number of cross veins. In *Bruchomorpha* (Fig. 33), a study of the adult wing alone seems to indicate a condition closely approximating the condition found in the Delphacida, in which radius and medius are coalesced for a considerable distance, radius diverging strongly and coalescing with medius throughout the middle of its course, and then diverging strongly toward the costal border of the wing. In all of the Issida that I have examined second and third anal are coalesced for nearly half of their course at

the tip. In *Thionia* (Fig. 36), the anal area of the hind wing is larger than the preanal area, and third anal is characterized by the addition of a large number of accessory veins. In *Bruchomorpha* (Fig. 34), the hind wing is greatly reduced in area, and the principal veins only are represented by simple unbranched veins.

#### Sub-family **Derbida.**

In this sub-family, also, subcosta and radius are coalesced for a considerable distance from the base, and both are typically two branched; although in some cases, *Otiocerus* (Fig. 39), there are a number of cross veins between subcosta and the costal border. Medius is typically four branched with a number of accessory veins added to medius one. In *Anotia* (Fig. 37), and *Otiocerus* (Fig. 39), there is an accessory vein between medius three and four. In *Lamenia* (Fig. 41), there are no accessory veins between medius three and medius four, and only a single accessory vein between medius one and medius two. Cubitus is typically two branched, but in *Otiocerus* and *Anotia* these branches do not extend to the anal border of the wing, but unite with the coalesced anals at some little distance from the border of the wing. In the hind wings, subcosta and radius are coalesced, and medius is two branched in *Anotia* (Fig. 38) and *Otiocerus* (Fig. 40), but unbranched in *Lamenia* (Fig. 42). Cubitus of the hind wing is two branched in all of the members of this sub-family which I have examined.

#### Sub-family **Cixiida.**

This sub-family also is characterized by the fact that subcosta and radius are coalesced for some distance from the base. Subcosta is typically two branched, although in *Bothriocera* (Fig. 60), *Oliarus* (Fig. 58) and *Æcleus* (Fig. 62) supernumerary veins are added between subcosta one and subcosta two. Radius is typically three branched, although these branches are somewhat variable in their relationships. Medius is typically four branched with an accessory vein between medius one and medius two, although in *Oliarus* (Fig. 58), both medius one and medius two bear accessory veins. Cubitus of the fore wing is typically two branched, and second and third anals are coalesced at the tip. In the hind wing subcosta and radius are coalesced for a considerable distance from the base,

and radius has two branches except in *Myndus* (Fig. 56). Medius is typically three branched except in *Æcleus* (Fig. 63), where it is only two branched. Cubitus is unbranched in *Myndus*, and two branched in all of the other members of this subfamily that I have examined.

#### Sub-family **Delphacida.**

In the fore wing, subcosta is typically two branched. Radius is coalesced with subcosta for about half of its length, when it diverges suddenly, then coalesces near the middle of its course with medius one plus two. It then diverges toward the costal border of the wing. Medius is typically three branched, the branches represented being medius one, medius two and medius three plus four. Medius three plus four frequently coalesces for a short distance with cubitus one, as in *Liburnia* (Fig. 53) and *Stenocranus* (Fig. 49). In *Stobæra* (Fig. 51), these two veins are connected by a short cross vein. Cubitus is three branched an accessory vein being developed along the anal side of cubitus one. In the hind wing, subcosta and radius are coalesced for more than half of their length and medius is unbranched. Cubitus is typically two branched, cubitus one coalescing for almost its entire length with medius, being separated only at its tip. The anal area of the hind wing is considerably enlarged and the third anal is frequently three branched.

#### ACKNOWLEDGEMENTS.

The writer wishes to express his appreciation for the kindly advice of Professor Herbert Osborn, and for the helpful criticisms of C. L. Metcalf, who furnished, also, the specimens of *Myndus radialis*, Osb., the only species of the subfamily Cixiida available for study. C. S. Brimley and Rev. A. H. Manee have furnished some material, but Luella Correll Metcalf has collected most of the material which was used as a basis for this paper.

## REFERENCES.

- Ashmead, W. H. 1889. A Generic Synopsis of the Fulgoridæ. Ent. Amer., V, 1-6 and 21-28.
- Edwards, J. A. 1896. The Hemiptera Homoptera of the British Islands.
- Melichar, L. 1896. Cicadinen von Mittel-Europa.
- Melichar, L. 1898. Monographie der Ricaniiden.
- Melichar, L. Monographie der Acanaloniiden und Flatiden.
- Melichar, L. 1906. Monographie der Issiden.
- Metcalf, Z. P. 1913. The Wing Venation of the Jassidæ. Ann. of the Ent. Soc. of Amer. VI, 103-115.
- Osborn, H. 1903. A Subterranean Root-infesting Fulgorid. Ohio Nat. IV, 42-44.
- Osborn, H. 1904. Note on Alate form of Phylloscelis. Ohio Nat. IV, 93-94.
- Swezey, O. H. 1903. Life History Notes on Two Fulgoridæ. Ohio Nat. III, 354-357.
- Swezey, O. H. 1904. A Preliminary Catalogue of the Described Species of the Family Fulgoridæ of North America North of Mexico. Bull. No. 3. Ohio Dept. of Agr.
- Van Duzee, E. P. 1897. A Preliminary Review of the North American Delphacidæ. Bul. Buf. Soc. Nat. Sci. V, 225-261.
- Van Duzee, E. P. 1908. Studies in North American Fulgoridæ. Proc. Acad. Nat. Sci. of Phila. December, 1907.
- Westwood, J. O. 1840. Observations on the Genus Derbe of Fabricius. Trans. of the Linn. Soc. XIX, 1-21.

## EXPLANATION OF PLATES.

## PLATE XXXII.

- Fig. 1. Fore wing pad of *Acanalonia* sp.  
 Fig. 2. Hind " " *Acanalonia* sp.  
 Fig. 3. Fore " " *Ormenis septentrionalis* Spin.  
 Fig. 4. Hind " " *Ormenis septentrionalis* Spin.  
 Fig. 5. Fore " " *Amphiscepa bivittata* Say.  
 Fig. 6. Hind " " *Amphiscepa bivittata* Say.  
 Fig. 7. Fore " " *Phylloscelis atra* Germ.  
 Fig. 8. Hind " " *Phylloscelis atra* Germ.

## PLATE XXXIII.

- Fig. 9. Fore wing of *Poiocera fuliginosa* Uhl.  
 Fig. 10. Hind " " *Poiocera fuliginosa* Uhl.  
 Fig. 11. Fore " *Cyrpoptus belfragei* Stal.  
 Fig. 12. Hind " *Cyrpoptus belfragei* Stal.  
 Fig. 13. Fore " *Ormenis septentrionalis* Spin.  
 Fig. 14. Hind " *Ormenis septentrionalis* Spin.  
 Fig. 15. Fore " *Amphiscepa bivittata* Say.  
 Fig. 16. Hind " *Amphiscepa bivittata* Say.  
 Fig. 17. Fore " *Acanalonia latifrons* Walk.  
 Fig. 18. Fore " *Elidiptera opaca* Say.  
 Fig. 19. Hind " *Elidiptera opaca* Say.  
 Fig. 20. Fore " *Catonia* sp.  
 Fig. 21. Hind " *Catonia* sp.  
 Fig. 22. Fore " *Phylloscelis atra* Germ.

## PLATE XXXIV.

- Fig. 23. Fore wing pad of *Scolops* sp.  
 Fig. 24. Hind " " *Scolops* sp.  
 Fig. 25. Fore " " *Dictyophara* sp.  
 Fig. 26. Hind " " *Dictyophara* sp.  
 Fig. 27. Fore " " *Thionia simplex* Germ.  
 Fig. 28. Hind " " *Thionia simplex* Germ.

## PLATE XXXV.

- Fig. 29. Fore wing of *Scolops perdix* Uhl.  
 Fig. 30. Hind " " *Scolops perdix* Uhl.  
 Fig. 31. Fore " " *Dictyophara florens* Stal.  
 Fig. 32. Hind " " *Dictyophara florens* Stal.  
 Fig. 33. Fore " " *Bruchomorpha oculata* Newm.  
 Fig. 34. Hind " " *Bruchomorpha oculata* Newm.  
 Fig. 35. Fore " " *Thionia bullata* Say.  
 Fig. 36. Hind " " *Thionia bullata* Say.  
 Fig. 37. Fore " " *Anotia* sp.  
 Fig. 38. Hind " " *Anotia* sp.  
 Fig. 39. Fore " " *Otiocerus coquebertii* Kirby.  
 Fig. 40. Hind " " *Otiocerus coquebertii* Kirby.  
 Fig. 41. Fore " " *Lamenia vulgaris* Fitch.  
 Fig. 42. Hind " " *Lamenia vulgaris* Fitch.

## PLATE XXXVI.

- Fig. 43. Fore wing pad of *Stenocranus* sp.  
 Fig. 44. Hind " " *Stenocranus* sp.  
 Fig. 45. Fore " " *Stobaera tricarinata* Say.  
 Fig. 46. Hind " " *Stobaera tricarinata* Say.  
 Fig. 47. Fore " " *Myndus radicis* Osb.  
 Fig. 48. Hind " " *Myndus radicis* Osb.

## PLATE XXXVII.

- Fig. 49. Fore wing of *Stenocranus lautus* V. D.  
 Fig. 50. Hind " " *Stenocranus lautus* V. D.  
 Fig. 51. Fore " " *Stobaera tricarinata* Say.  
 Fig. 52. Hind " " *Stobaera tricarinata* Say.  
 Fig. 53. Fore " " *Liburnia ornata* Stal.  
 Fig. 54. Hind " " *Liburnia ornata* Stal.  
 Fig. 55. Fore " " *Myndus* sp.  
 Fig. 56. Hind " " *Myndus* sp.  
 Fig. 57. Fore " " *Cixius* sp.  
 Fig. 58. Fore " " *Oliarus 5-lineatus* Say.  
 Fig. 59. Hind " " *Oliarus 5-lineatus* Say.  
 Fig. 60. Fore " " *Bothriocera pro-signoretta*.  
 Fig. 61. Hind " " *Bothriocera pro-signoretta*.  
 Fig. 62. Fore " " *Æcleus decens* Stal.  
 Fig. 63. Hind " " *Æcleus decens* Stal.



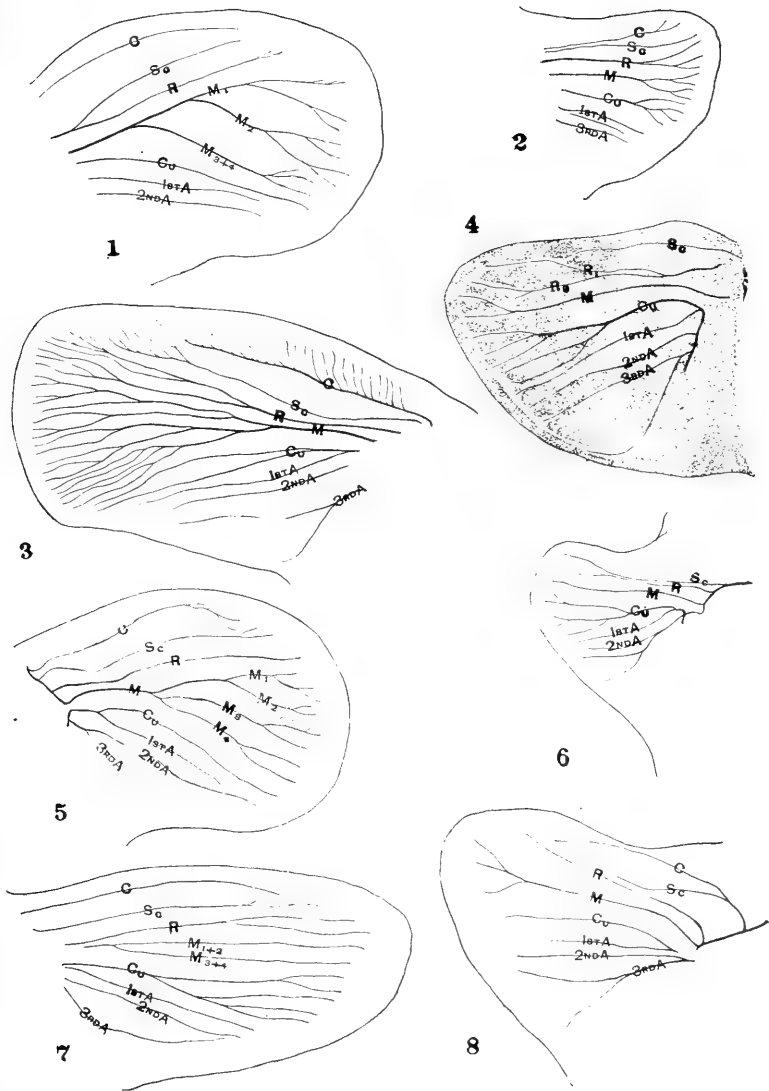

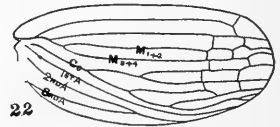
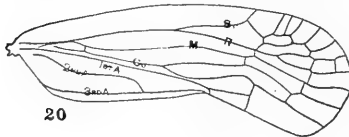
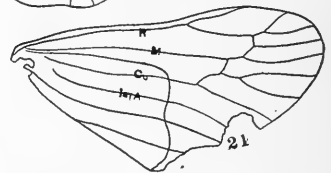
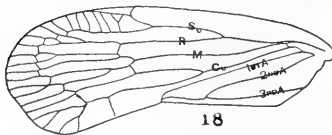
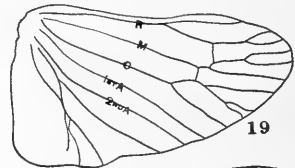
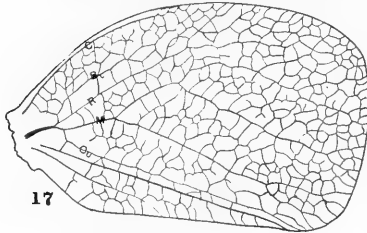
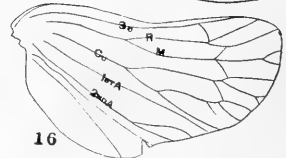
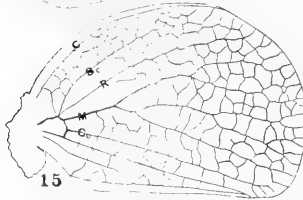
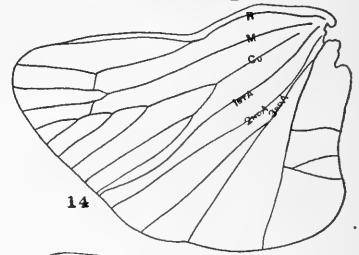
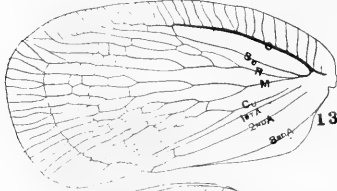
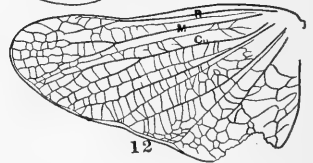
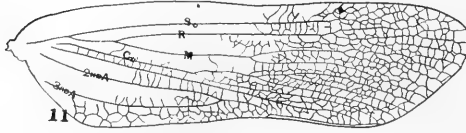
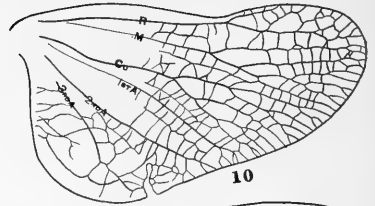
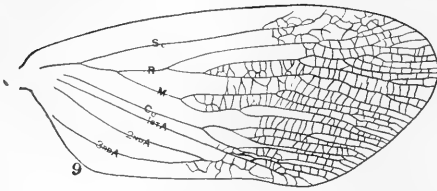

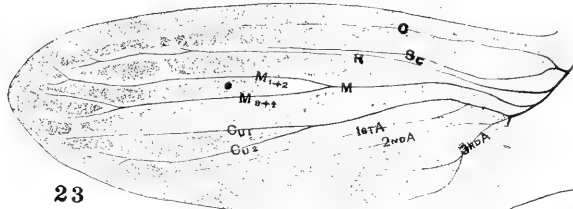

23

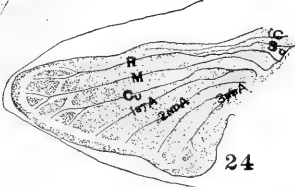

24

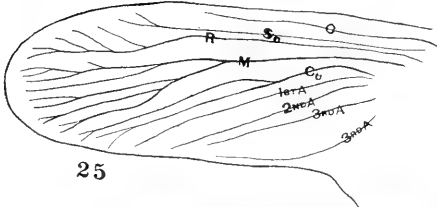

25

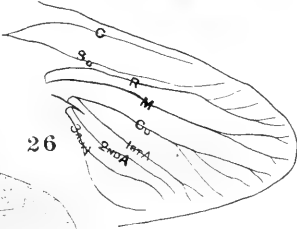

26

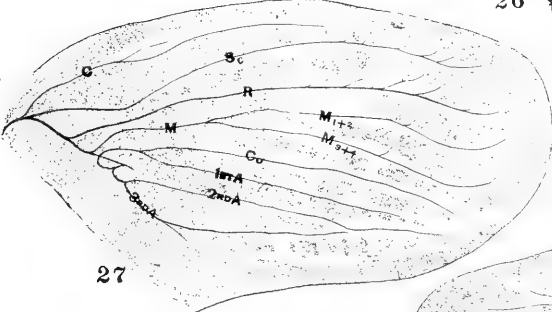

27

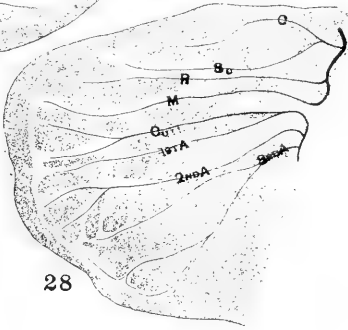

28

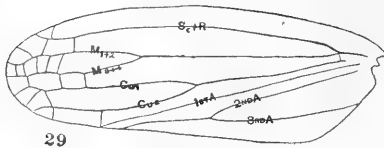

29

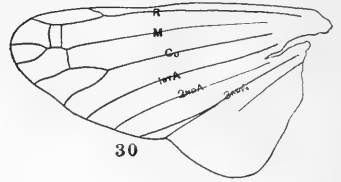

30

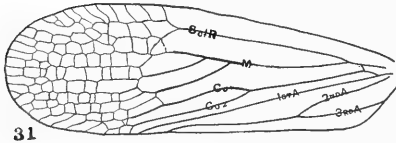

31

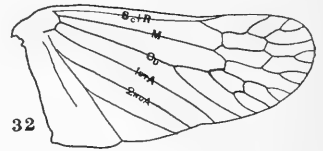

32

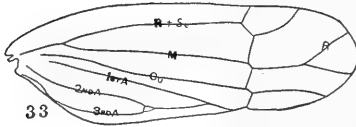

33

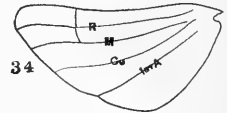

34

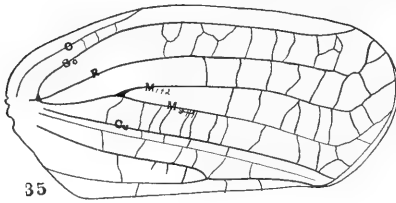

35

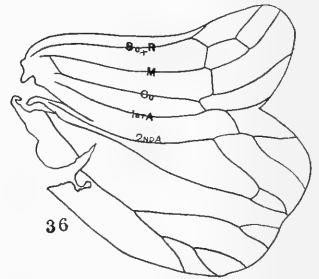

36

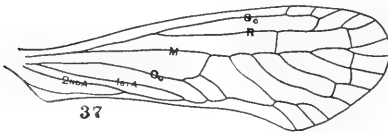

37

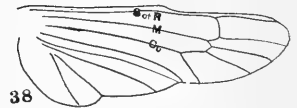

38

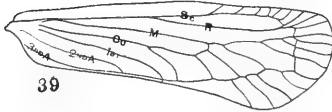

39

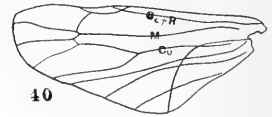

40

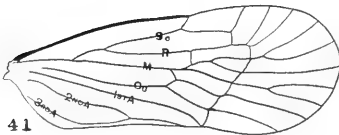

41

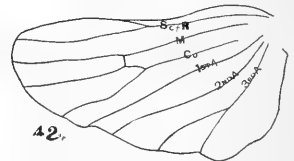

42

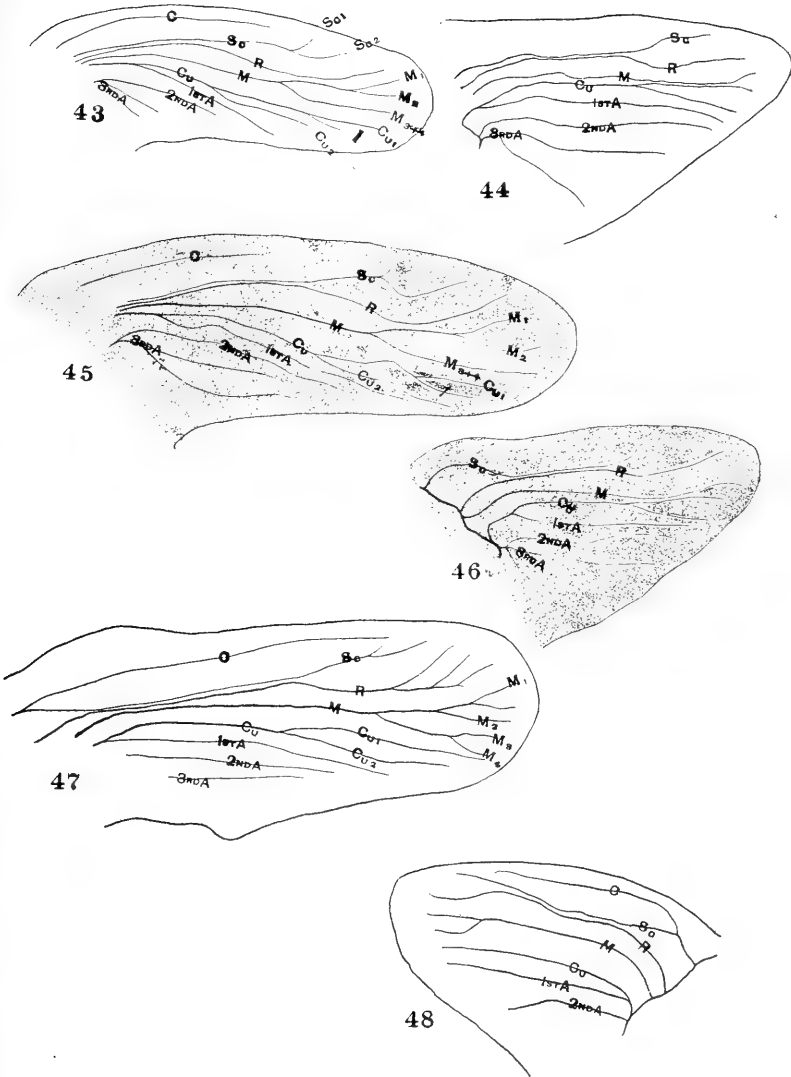

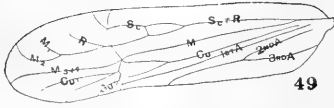

49

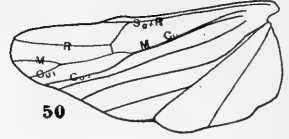

50

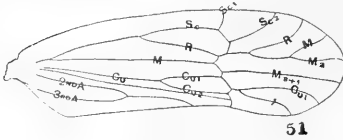

51

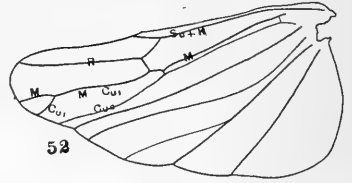

52

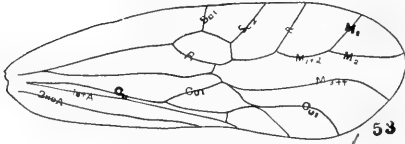

53

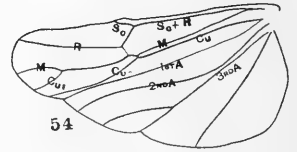

54

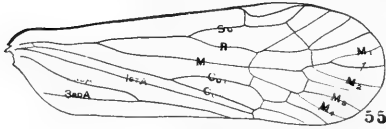

55

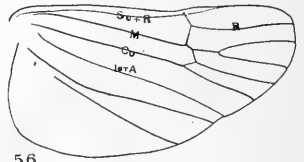

56

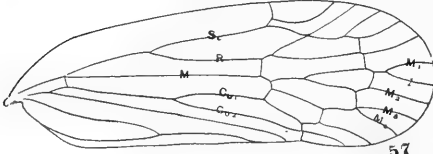

57

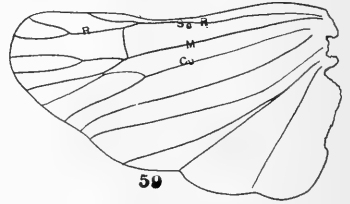

58

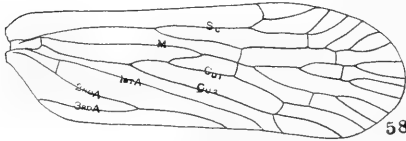

59

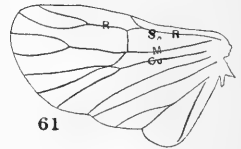

60

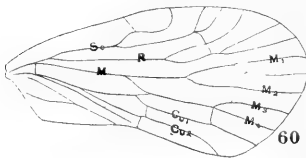

61

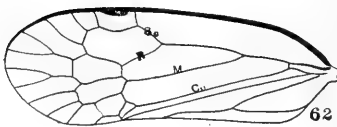

62

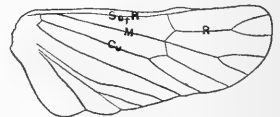

63

# THE PRINCETON COLLECTION OF FOSSIL BEETLES FROM FLORISSANT.

By H. F. WICKHAM, Iowa City, Iowa.

Through the kindness of Professor Gilbert van Ingen, of the Department of Geology of Princeton University, I have been allowed to study the collection of Florissant fossil beetles in his care. The series is of particular interest since it forms a part of the material used by Scudder in working up two of his principal papers on the Tertiary insects\* and contains many of his types and cotypes. He studied the present collection with special reference to the Adephaga, Clavicornia and Rhynchophora and in these groups described practically all of the novelties which were in sufficiently good condition for that purpose. With the exception of *Atenius patescens*, for the determination of which I am responsible, all of the species attributed to his authorship in the following list were identified by him and the specimens represent the originals which served as the bases of his descriptions. Those attributed to myself are either lately published or now in press elsewhere. Ten are described as new. The drawings are made with a camera lucida and represent only what actually remains of the specimens, there being no attempt to restore lost parts or to idealize any of the characters.

As in all collections of fossil insects, a good many of the specimens are in too poor preservation to repay study, but it is possible to recognize the forty-two species listed below.

## Carabidæ.

*Bembidium tumulorum* Scudd.  
*Pterostichus walcotti* Scudd.  
*Amara danæ* Scudd.  
    *sterilis* Scudd.  
*Harpalus whitfieldii* Scudd.

## Staphylinidæ.

*Staphylinus lesleyi* Scudd.  
*Philonthus abavus* Scudd.  
*Xantholinus tenebrarius* Scudd.  
*Lithocharis scottii* Scudd.  
*Bledius morsei* Scudd. (?)  
    *osborni* Scudd.

## Coccinellidæ.

*Coccinella sodoma* n. sp.

## Cryptophagidæ.

*Antherophagus megalops* n. sp.

## Dermestidæ.

*Dermestes tertiarius* Wickh.  
*Attagenus aboriginalis* n. sp.

## Byrrhidæ.

*Byrrhus romingeri* Scudd.

## Buprestidæ.

*Melanophila handlirschi* Wickh.

\*Monographs of the United States Geological Survey, Vols. XXI and XL.

Lampyridæ.  
 Podabrus wheeleri Wickh.  
   cupesoides Wickh.  
 Telephorus humatus n. sp.  
 Trypherus aboriginalis n. sp.

Ptinidæ.  
 Xestobium (?) alutaceum n. sp.

Scarabæidæ.  
 Atænius patescens Scudd.  
 Aphodius aboriginalis Wickh.

Cerambycidæ.  
 Callidiopsites grandiceps n. sp.  
 Leptura leidyi n. sp.

Chrysomelidæ.  
 Crioceridea dubia Wickh.

Cistelidæ.  
 Cistela antiqua n. sp.  
 Capnochroa senilis n. sp.

Rhynchitidæ.  
 Paltorhynchus narwhal Scudd.  
 Trypanorhynchus depratus Scudd.

Otiorhynchitidæ.  
 Evopes occubatus Scudd.  
 Eudomus robustus Scudd.  
   pinguis Scudd.

Curculionidæ.  
 Geralophus occultus Scudd.  
   fossicius Scudd. (?)  
   lassatus Scudd.

Cleonus primoris Scudd.  
 Cremastorhynchus stabilis Scudd.  
 Anthonomus arctus Scudd.  
 Tychuis evolatus Scudd.  
 Aulobaris damnata Scudd.

### **Coccinella** Linn.

**C. sodoma** n. sp. (Plate II, Fig. 1). Outline subcircular, of the ordinary form of **Coccinella** if allowance be made for flattening. Sculpture extremely fine, consisting only of the alutaceous roughening common in the genus. Scutellum a little larger than in the recent North American species of **Coccinella**. Length, 7.75 mm.

Type in the Museum of Princeton University, number 6561.

An extended description seems unnecessary, since the figure will show the proportions of the different parts of the body. While it is safer to consider the generic reference as applying in the Linnæan sense, there is nothing about the specimen which would seem to throw it out of **Coccinella** proper. It is a little larger than the average *C. transversoguttata*, the common species of the Rocky Mountains today. No definite color pattern can be distinguished.

### **Antherophagus** Latr.

**A. megalops** n. sp. (Plate I, Fig. 1). Form subparallel and moderately elongate, the entire surface devoid of any distinct sculpture though there are faint signs of shallow, broad, elytral sulcations, a few small punctures towards the sides of the pronotum and what seem to be hair marks on the prothorax and elytra. Head large, about one and one-half times as long as the pronotum, slightly longer than wide, sides a little convergent anteriorly, front margin indistinctly preserved, but apparently about truncate. Eyes submedian in position, large and rounded, separated above by less than the width of one of them.



Antennæ submoniliform, slightly incrassate exteriorly, first joint large, second short, third longer than the fourth, though not much so, fourth to eighth subequal, the remaining three forming a weak club. The eleventh joint is damaged in this specimen, so that the exact form cannot be made out. Prothorax very short, about twice as broad as long, the form of the sides distorted, one appearing to be straight with the anterior angle distinct while the other is arcuate with the angles nearly obliterated. Scutellum absent or not defined. Elytra about one and one-half times as long as broad, apices, in life, probably conjointly rounding through as preserved they are separately sub-cuminate at tip. Legs wanting. Length, 4.30 mm.

Type in the Museum of Princeton University, obverse and reverse, numbers 6564 and 6535.

The head is larger than in the modern species of *Antherophagus* that I know and the eyes are of much greater size in the fossil. It may be necessary, some day, to erect a new genus for this insect, but for the present, it seems better to allow it to remain in *Antherophagus*.

#### Dermestes Linn.

**D. tertiarius** Wickh. (Plate II, Figs. 2 and 3). A specimen contained in this collection is in much more perfect condition than the type and shows a few additional features. The head is of normal size and punctured a little more strongly than the prothorax. The right antenna is displayed in sufficiently good preservation to show that it is very similar to that of the recent **D. marmoratus** except that the two joints immediately preceding the club are a trifle broader. The vestiture, punctuation and size are as described for the type.

On account of the imperfection of the type, which was used for the original figure, new drawings from the Princeton specimen are given herewith. The generic reference seems to be completely sustained by this example. It carries the Princeton Museum number 6613.

#### Attagenus Latr.

**A. aboriginalis** n. sp. (Plate II, Fig. 4). Form elongate, sub-elliptical. Head of moderate size, deeply inserted in the prothorax, minutely sparsely punctulate, eye rather small. Prothorax along middle a little less than one-half the basal width, sides arcuate, dissimilarly so in the specimen, front and hind angles well defined, apical emargination moderately deep, base rather strongly lobed at middle and sinuate each side, disk minutely punctulate or nearly smooth. Scutellum small, triangular. Elytra about three and three-fourths times the length of the prothoracic median line, not striate, punctuation minute, surface with signs of a fine hairy vestiture. Length, 5.00 mm.

Type in the Museum of Princeton University, number 6290.

The form, size, thoracic outline (especially the shape of the base), the proportions of the abdominal segments and the vestiture all point to this generic assignment. The sculpture seems to have been finer than that of any of the recent North American species with which I am acquainted, and this character will separate it from the fossil *A. sopitus*.

#### **Telephorus** Schöff.

**T. humatus** n. sp. (Plate I, Fig. 2). Form subparallel, rather narrow. Head crushed so as to appear excessively large, particularly since the basal antennal joints are thereby merged with the genæ. Eye moderately large, rounded. Antennæ equal to a little more than one-half the body length, first joint not distinguishable, second small, third shorter than the fourth, remainder subequal in length, all except the distal three with the inner angles produced so as to appear moderately serrate. Prothorax transverse, sides and apex rounded. Scutellum of normal size, triangular. Elytra four times the length of the prothoracic median line, rounded at apices. Legs rather short. Length, 7.50 mm.

Type in the Museum of Princeton University, number 5984.

In form and size this insect resembles the recent *T. bilineatus* quite closely. The sculpture is of the fine alutaceous type common in the genus.

#### **Tryptherus** Lec.

**T. aboriginalis** n. sp. (Plate I, Fig. 3). Form similar to that of the recent **T. latipennis**. Head a little distorted, but evidently of moderate size. Antennæ slender, filiform, the joints not serrate, but too poorly preserved to describe as to their relative lengths. Prothorax about as wide as the head, transverse, apex narrower than the base, sides moderately strongly rounded. Elytral length equal to twice the prothoracic width, apices narrowed, but rounded, sculpture strongly scabrous. Abdomen with several segments exposed beyond the elytral tips, without visible terminal appendages. Legs wanting, except one femur, which is rather slender. Length, 8.75 mm.

Type in the Museum of Princeton University, number 6527.

There is little doubt that this insect is closely allied to *Tryptherus* if not an actual member of the genus. It has the size, form, sculpture and general appearance of the recent *T. latipennis*, common in the eastern half of North America.

The hind wings are spread and exposed, showing the basal portions of the venation quite well. A comparison of the figure of the fossil with the accompanying one of the wing of *T. latipennis* will show the close general correspondence between them. The dotted lines in the latter figure show as transparent markings on the general ground, but in the fossil the upper one of these is not visible while the lower one seems to have been strongly pigmented.

#### *Xestobium* Motsch.

**X. (?) alutaceum** n. sp. (Plate I, Fig. 5). Form nor very elongate. Head large, deflexed, eye about circular and rather small compared with that of most recent Anobiini. Pronotum somewhat gibbous dorsally at about the middle, projecting anteriorly over the head. Elytron with a rather weak epipleural lobe within which is a fine but distinct stria, apex apparently rounded. Legs short and only moderately stout. Length, from front of pronotum to abdominal apex, 6.65 mm.

Type in the Museum of Princeton University, number 6575.

In a general way, this species slightly resembles the Florissant fossil *Xylobiops lacustre*, but the proportions are different and the sculpture of the present species is very fine. The entire upper surface shows traces of a minute scabrosity, but the abdomen is almost entirely smooth. The elytra are not striate except inside the epipleural margin. By the small eyes, the size, sculpture and general form, this seems to approach *Xestobium*, but the generic reference must be considered provisional, the most dubious character being the large head.

#### *Callidiopsites* n. gen.

This generic name is proposed for a Cérambycid fossil which shows affinities with *Callidium* in the broad short form, short stout antennæ, heavy legs, transverse and nearly or quite confluent front coxal cavities, and coarse elytral sculpture. It differs in the mesosternum, being much narrower between the middle coxæ and the head very much larger. It is not entirely in agreement with any of the recent genera of Callidioides known to me and it seems better to give it a separate generic assignment. The type is *C. grandiceps*, described below.

**C. grandiceps** n. sp. (Plate III). Form rather short and stout, outline, as preserved, not unlike some species of **Patrobis** in the Carabidæ. Head large, nearly as long as broad and decidedly longer than the prothorax. Eyes not definable. Antennæ extending a little beyond elytral two-thirds, moderately stout, the first joint large and thick, third not greatly elongate, tenth and eleventh distinctly shorter than the two preceding. The joints are apparently carinate along their faces. Prothorax very short, a little wider than the head. Elytra (likely enough from abdominal distention due to maceration) not completely covering the dorsal segments, their apices separately rounded, surface coarsely closely punctured with some indication of striae at the outer margins. Thighs heavy, somewhat clavate, especially the middle and hind pairs. Apex of abdomen extruded, displaying a simple, straight sex organ. Length, to extended tip of abdomen, 15.25 mm.; of elytra, 8.25 mm.

Station number 13B. One specimen, collector not specified, was received from Professor Cockerell. The type is in the Museum of the University of Colorado. Another is contained in the Princeton collection, with the number 6543.

This looks like a Carabid, but what can be seen of the structure of the underside together with the large antennæ incline to the assignment given above. The antenna figured is a trifle too slender, since it is a camera lucida drawing and the edges of the organ were not entirely freed from the matrix.

#### **Leptura** Serv.

**L. leidyi** n. sp. (Plate I, Fig. 6). Form, judging from the remains, subparallel, as in the recent **L. sphaericollis**. Head apparently incomplete in front of the eye, which is reniform, distinctly emarginate and of rather small size. Antennæ not preserved, except a few of the basal joints which are relatively shorter than usual in the living forms. Prothorax a little damaged, but apparently not strongly campanulate. Elytra subparallel to apices which are separately rounded and not much narrowed. Surface sculpture everywhere very fine, the elytra seemingly with a delicate pubescence. Legs moderately long. Length, from front of head to abdominal apex, 7.50 mm.

Type in the Museum of Princeton University, number 6512.

The small size will at once separate this from any of the other described species of Florissant *Lepturæ*, and the fine sculpture serves to differentiate it from *L. antecurrens* which comes nearest in length. Like the other fossils from Florissant ascribed to this genus, it must be considered a *Leptura* in the wide sense only. It is named after Joseph Leidy, zoologist and palæontologist.

**Cistela** Fabr.

**C. antiqua** n. sp. (Plate IV). Form fairly stout. Head finely rather densely punctulate and hairy. Eyes, as shown by their sockets, moderately large. Antennæ slender, the basal two joints not definable, the remainder sub-equal, scarcely serrate, the distal ones not incrassate; if directed backwards, the antennæ would reach nearly to the basal fourth of the elytra. Prothorax broad at base, narrowed at apex, sides gently arcuate, surface finely punctulate and hairy like the head, but more distinctly. Scutellum of moderate size, sculptured like the thorax. Elytra not alike in outline on account of the specimen being crushed askew, but the left one, which seems to be the better preserved, is a little more than four times the length of the prothoracic median line, tapering to the rather sharply rounded apex. Elytral sculpture and vestiture like that of the pronotum. Legs wanting. Length, from front of head to elytral apex, 13.10 mm.

Type in the Museum of Princeton University, number 6534.

The appearance of this insect is that of a *Cistela* with estriate elytra and slender antennæ. Compared with the North American species known to me, it comes closest to *C. pinguis* from Colorado. It is about the size of the fossil *Capnochroa senilis*, but that insect has striatopunctate elytra.

**Capnochroa** Lec.

**C. senilis** n. sp. (Plate II, Fig. 5). Form elongate, subparallel as far as shown, but the elytral apices are broken off. Head rather large for this genus, transversely finely subrugose. Eyes, as displayed, transversely elliptical and of good size. Palpus (probably the maxillary) with the terminal joint roughly triangular, moderately dilated. Antennæ relatively less elongate than in the recent *C. fuliginosa*, not serrate, second joint shorter than the third, which is not so long as the fourth. Prothorax narrowed anteriorly, the more perfect side about straight, anterior coxæ narrowly separated by the prosternum. Scutellum of moderate size. Elytra long, if complete they would be about six and one-half times the median prothoracic length, rather coarsely striate and punctate. Legs moderate or rather short, not excessively slender, the tarsi, as far as shown, a little shorter than the tibiæ, claws large, the front ones apparently pectinate. Length of fragment, 12.40 mm.; if entire, the insect would reach about 14.00 mm.

Type in the Museum of Princeton University, number 6902.

While the generic reference must be considered somewhat doubtful, it seems safe to assume that the fossil represents a large Cistelid belonging in the same neighborhood as *Capnochroa*. The texture is very like that of the Cistelidæ, the

prosternum being strikingly like that of *Capnochroa* and setting up strongly in the same way. The arrangement of the coxæ is as in that genus and the front tarsi correspond very well. The form of the palpus is similar. Under high power, the claws show transverse markings, which I think are the somewhat obscured pectinations. The strength of the elytral sculpture is indicated by its showing through, although the specimen is preserved as an underside. A disturbing element is introduced by the antennæ, which are shorter and less serrate than in the modern species, but I dislike to found a new genus upon this character alone. Our living *Capnochroa fuliginosa* occurs in the Atlantic district and as far west as the Mississippi Valley.

---

EXPLANATION OF PLATES.

PLATE I.

- Fig. 1. *Antherophagus megalops* n. sp.  
 Fig. 2. *Telephorus humatus* n. sp.  
 Fig. 3. *Trypherus aboriginalis* n. sp.  
 Fig. 4. *Trypherus latipennis*, (recent), hind wing.  
 Fig. 5. *Xestobium* (?) *alutaceum* n. sp.  
 Fig. 6. *Leptura leidy* n. sp.

PLATE II.

- Fig. 1. *Coccinella sodoma* n. sp.  
 Fig. 2. *Dermestes tertiaris* Wickh.  
 Fig. 3. *Dermestes tertiaris*, antenna.  
 Fig. 4. *Attagenus aboriginalis* n. sp.  
 Fig. 5. *Capnochroa senilis* n. sp.

PLATE III.

- Callidiopsites grandiceps* n. sp.

PLATE IV.

- Cistela antiqua* n. sp.

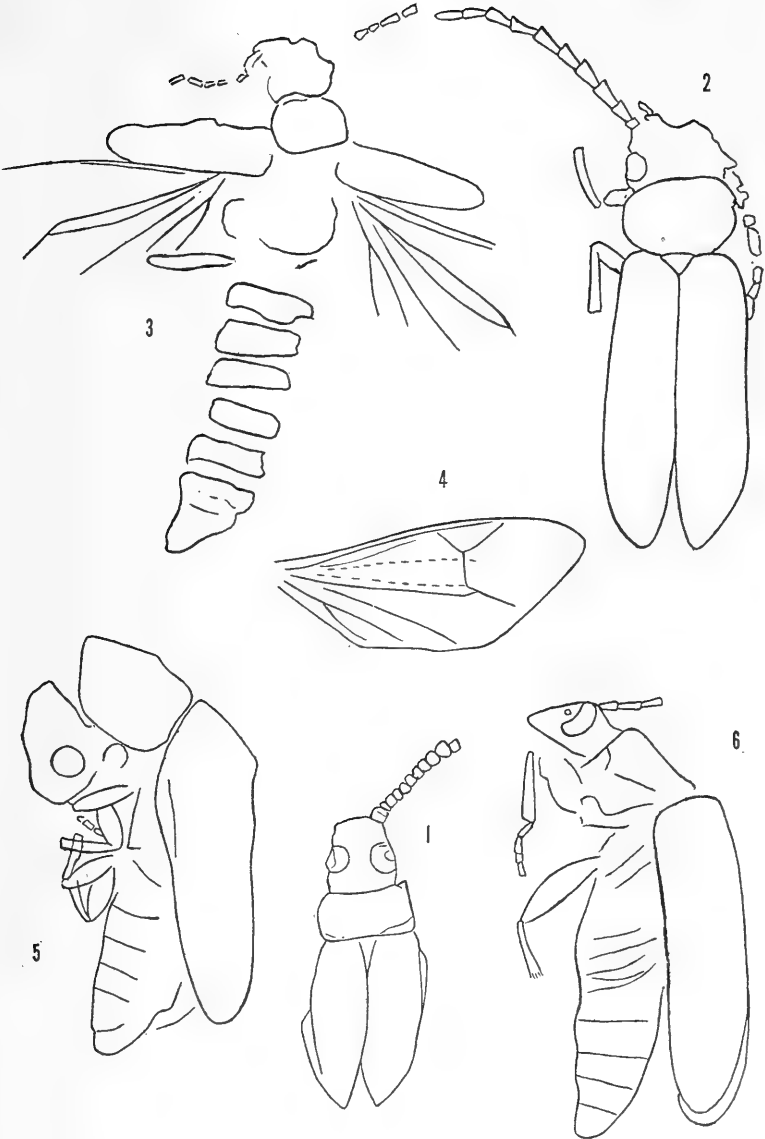

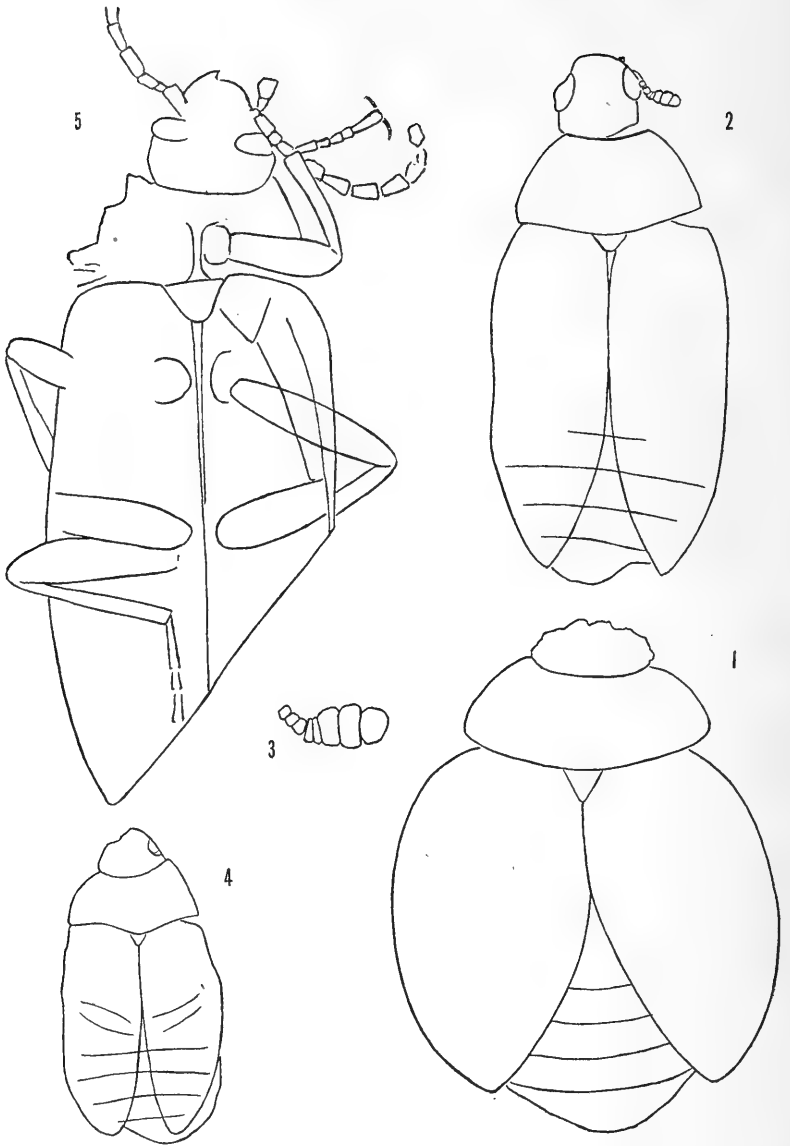







*H. F. Wickham.*

# A CONTRIBUTION TO THE BIOLOGY OF MAY-FLIES.\*

ANNA H. MORGAN.

## CONTENTS.

I. Introduction.....	371
II. Historical.....	372
III. Life Cycle.....	377
Embryo, Nymph, Sub-imago, Imago.	
IV. Modifications of structures of the nymph.....	380
Habitat, Shape of body, Gills, Food, Mouth-parts, Legs.	
V. Modifications of Adult Structures.....	392
Mating, Alimentary Canal, Legs, Genitalia.	
VI. Eggs.....	397
VII. Bibliography of the Order.....	401

## I. INTRODUCTION.

This is a study of the habits and structure of May-flies. It describes the situations in which they live and some of the adjustments which they have made to the conditions in them. The two problems which face every organism are those of maintaining its own life and continuing its race. Its youth is devoted entirely to satisfying its individual needs for food and safety; its adult life is devoted to the race, but the necessities of the individual are still satisfied though they may be secured in an entirely different way. The immature life of May-flies is aquatic, and to it all adjustments concerned with food or safety are exclusively confined. The mature or adult life is aerial. It is solely devoted to reproduction. There is no provision for food or for other means of lengthening its life. It gives an opportunity for studying ways of getting a living which have been completely isolated from ways of reproducing. The study which follows has been divided into five sections.

1. The historical sketch, in which the more important papers which have dealt with May-fly biology are briefly discussed.

2. The life cycle which consists of a brief statement of the characteristics of the three stages of life.

3. The evolution of the nymphs in which progress from a generalized to a specialized condition is shown in changes of shape and function of gills, mouthparts, and legs.

---

\*Contribution from the Limnological Laboratory of Cornell University. This work was done under the direction of Professor James G. Needham, of whose kindly criticism and stimulating interest I wish to express my appreciation. I wish also to thank Miss Anna C. Stryke for her many helpful suggestions regarding the drawings and the photographs from which some of the drawings have been taken.

4. The evolution of the adult in which specialization is shown by changes of function and developments for the furtherance of reproduction.

5. Adjustments for aquatic situations shown in the structures of the eggs.

6. A Bibliography of biological, morphological, and the more important systematic works dealing with this group.

## II. HISTORICAL.

In the following historical sketch I have tried to select the more important papers of biological significance. In many cases, however, systematic, morphological, and biological work have been so closely related that such a separation has been impossible.

*Swammerdam*. 1661. The foundation study of the biology of May-flies was made by Johann Swammerdam, at Culenburg, on the Rhine, in 1661. As a field naturalist, he learned the most important facts concerning the life of Ephemerus, (probably *Palingenia longicauda* Oliv.). As an anatomist he dissected and studied its internal and external structure with great care. He described the emergence of the nymph, the sub-imago stage in males, and the final or imago stage in which he believed that the eggs and the sperm were deposited separately in the water. He concluded that no food was taken during aerial life, and that copulation did not occur. He examined the eggs and tested their power of dispersal by letting them fall into the water from the end of a knife. His work is a remarkably truthful and interesting record. Later works have added and corrected, but none have contributed better biology.

*Reaumur*. 1742. In *Memoires des Insectes*, 1742, Reaumur reviewed much which had already been told by Swammerdam, and illustrated more profusely the life history of a burrowing May-fly, probably also *Palingenia*. Some of Reaumur's observations were made upon nocturnal species. After he had noticed them swarming about a light near the river bank, he placed a tub of water in his own garden. By holding a light above this, in the evening, he was able to gather great numbers of May-flies and to watch their transformation from the sub-imago to the imago stage, and to see them lay their

eggs in the water. He counted the eggs which he found protruding from the abdomens and determined the average number to be 750 to 800 for each female. He disagreed with Swammerdam regarding the fertilization of the eggs, and stated that the males and females probably did mate, and that the forceps of the male were evidently for the purpose of seizing the female.

*DeGeer*. 1748. In 1748 DeGeer saw the mating\* actually take place. Two years later he again saw the mating flight and the mating, and this time was able to give more facts concerning it. The swarm consisted mostly of males. In mating the male was beneath the female with his abdomen recurved upward so that its tip rested against the two openings of the oviducts, between the eighth and ninth segments. Copulation lasted but an instant, and De Geer was not able to observe the process in detail. He described several different varieties of May-flies, distinguishing them by descriptive color names. The double eyes of a diurnal May-fly (possibly a *Leptophlebia*) were mentioned, the larger eyes being named the turbinate eyes.†

*Geoffroy*. 1764. Geoffroy, 1764, saw great swarms of May-flies near Paris and noted that there they were called "manne de poissons," because great numbers fell down into the streams to the fishes. He accurately figured and described as a Crustacean,‡ the May-fly, later determined by Vayssiere as *Proscopistoma*, which he found in the riffles of a stream near Paris.

*Newman*, 1836. In discussing the transformations of insects, Newman, 1836, wrote of May-flies as follows: "Here then we have the strange fact of an insect's flying before it reaches the imago; that is, flying in the penultimate state. It thus appears that although until the final ecdysis, no insect arrives at perfection; yet before that period, even in the state immediately preceding, it may feed, run and even fly; or it may swim, crawl, barely move, or be without motion."

*Bowerbank*, 1833. Bowerbank studied the circulation of the blood in young nymphs of *Ephemera marginata*. He carefully examined the dorsal vessel with its valves and described the circulation of the blood. He was the first to see

\*DeGeer, 1748, T. II, p. 644.

†DeGeer, 1748, T. II, p. 651.

‡Geoffroy, Tom. II, p. 658. "Le Binnocle a queue en plumet."

in the setæ the two currents of blood which have since been carefully studied.

*Westwood*, 1840. In 1840 Westwood discussed the classification of May-flies, following the discussion with some biological facts mostly gathered from previous writers.

*Burmeister*, 1848. Burmeister made the first real contribution to May-fly embryology. While sitting in his room one evening, many females of *Palingenia horaria* flew through the open window and began depositing eggs upon his table. Burmeister described these eggs and figured them. He placed some of them in water on July 22 and on August 2 he freed an embryo from the shell. He studied this stage carefully and figured it showing the mouth-parts, legs and gills.

*Leuckart*, 1858. Ten years later Leuckart carefully described the eggs of three May-flies. This work was followed by

*Grenacher*, 1868. Grenacher's short, but important paper, "Beitrag zu Kenntniss des Eies der Ephemeriden." He studied eggs similar to those cited by Leuckart and showed that the polar knobs described by him were to be found in various stages within the ovary. So far as known, Leuckart and Grenacher have been the only authors who have made any careful study of these egg structures in May-flies.

*Pictet*, 1843. The first general study of this group was the monograph in the "Historie Naturelles des Insectes Neuropteres" by Pictet. He classified preceding biological and systematic studies and gave a history of each, reviewing all of the most important contributions from Aristotle to 1840. He described the habits of his four classes of nymphs, fossorial, flattened, swimming and crawling. He discussed the emergence of the nymph and features of the sub-imago and imago stages, but he gave many details less satisfactorily than Swammerdam or Geoffroy.

*Dufour*, 1849. In 1849 Leon Dufour published a memoire on the different kinds of respiration in insects. In this he classified May-flies with insects breathing by means of external organs. This study was followed by the similar ones of Mueller, 1851, and Milne Edwards, 1857.

*Lubbock*, 1863-6. After the first contribution to May-fly embryology by Burmeister in 1848, no further investigations were made until 1863-6, when Sir John Lubbock published two papers, "On the Development of *Chloeon dimidiatum*."

In these two studies he followed individuals through twenty-three successive moults, tracing them to the adult stage. He did not, however, begin his observations at the actual time of hatching as Burmeister had done.

*Hagen*, 1849-1890. The foundation for the study of May-flies in North America was made largely through the inspiration and contributions of Prof. Hermann Hagen. Although the greater part of his work was systematic, the notes which he sent to Eaton in 1873 show that he made valuable additions to the knowledge of their biology. Hagen identified the nymph of *Baetisca* which B. D. Walsh described in 1864.

*Walsh*, 1864. Walsh concluded his paper on *Baetisca* with a description of the swimming habits of the nymphs which he kept for some time under observation.

*Eaton*, 1870. About the end of 1870, Rev. A. E. Eaton submitted to the Entomological Society of London the most important work done upon the group since Pictet's monograph. In 1883-86, the completed work was published in the Transactions of the Linnean Society.

*Eaton*, 1883. In this work the world fauna was reclassified and a great number of forms were described and figured with such accuracy that it at once became and has remained the most important work upon the order. The introduction contained a general account of the biology which included several of Dr. Hagen's\* field notes.

*N. Joly*, 1876. Joly, '76, studied the embryology of *Palingenia virgo*. He kept eggs in dishes of water and recorded the structures of the developing embryo on the 5th and 6th day. This work was followed by another by N. and E. Joly, which dealt mostly with the structure of the systems in the nymphal and imago stages of certain species.

*Vayssiere*, 1882. Vayssiere published the first extensive study of the nymphs. This paper was written almost entirely from a morphological view point, but it contains many references to short biological papers.

The papers of Zimmerman, '79, Eaton, Hagen, Joly, Palmer, '83, Creutzburg, '85, and others were mainly morphological.

---

\*1873. Hagen Notes on the Ephemeroidea. Compiled by Eaton.

*Fritze*, 1889. Fritze, '89, studied the structure of the alimentary canal. He described and figured a muscular apparatus in the oesophagus, and discussed its changes of function in the adult.

*Heymons*, 1896. In a paper upon the embryology of *Ephemera vulgata*, Heymons, '96, stated that the eggs hatched eleven days after they were laid. He traced the development of the nymphs up to the age of four days. He discussed the ancestry of May-flies, and concluded that their life was originally entirely aerial and that the closed tracheal system of the nymphs is an accomodation to aquatic life.

*Causard*, 1896. Causard noted the birth of living young in *Ephemera vivipare* and briefly described the development of the nymphs.

*Hubner*, 1902. Hubner, '02, tested the regenerative powers of nymphs of *Cloeon dipterum*. Certain nymphs regenerated the last abdominal segment with its appendages. The alimentary canal became functional, and the insect lived for one month.

*Tumpel*, *Needham and Betten*, 1901. In the same year two general papers were published. "Die Geradflügler Mitteleuropas" by Tumpel and several complete life histories in "Aquatic Insects of the Adirondacks" by Needham and Betten.

A similar but much more extensive work by Needham followed in 1905 and 1908. In the introduction to this study May-fly nymphs were described as "perhaps the dominant insect herbivores of fresh water." Their herbivorous diet and their importance in the economy of aquatic life were for the first time emphasized.

*Sternfeld*, '07. Sternfeld, '07, worked upon the atrophy of the mouth-parts and the changes in function of the alimentary canal. He reviewed Fritze's paper and considered the biological significance of the structures much more fully. He concluded that the alimentary canal in imago May-flies is by no means rudimentary and that a muscular apparatus, which is under voluntary control, regulates the supply of air in it. The decrease of specific gravity caused by this "swimming bladder" aids the insects in the mating flight and hence indirectly influences their multiplication.



*Drenkelfort*, '10. Drenkelfort wrote a general account of the biology of *Siphylurus lacustris*.

*Wodsedalek*, '11. Wodsedalek experimented upon nymphs of *Heptagenia interpunctata* Say and found that they were repelled by light, but that these reactions could be reversed by the addition of certain chemicals to the water.

### III. LIFE CYCLE.

The life cycle of May-flies includes the embryonic period within the egg, and the active life which is divided into nymphal, sub-imago and imago stages.

Almost the earliest studies of the embryos were made by Burmeister, '48, who described those of *Palingenia horaria* twelve days after laying. He noted the rudiments of the mouth parts and legs. According to Joly, '76, embryos of *Palingenia virgo* take about two months for development. Heymons, '96, found that eggs of *Ephemera vulgata* kept in a temperature of 20-25 C would hatch in ten to eleven days. At hatching they measured 1 mm. with setæ inclusive. The antennæ and setæ were respectively five and four segmented. External gills were not yet present, but all of the systems were complete except the reproductive. On segments two to seven of the abdomen was a series of lateral hypodermal thickenings. Heymons believed that the gills which arouse four days later were outpushings of these thickenings. He held the gills to be lateral projections homologous with the legs and not of dorsal origin as often considered. From the structures in the embryo he concluded that a homology between gills and wings is unfounded.

By nymphal stage is meant the period of life between hatching and emergence from the water. The exact limits of its duration are unknown. Lubbock, '66, followed a *Chloeon dimidiatum* through twenty-three moults to the imago stage, but his data does not begin at time of hatching. *Hexagenia variabilis* lays its eggs in April and May, but I have found large and small nymphs abundant in the same locality in the March preceding, so that they must require at least two years to mature. Nymphs of *Callibaetis fluctuans* mature in about six weeks in mid-summer. As already noted, May-flies quit the egg in a fairly advanced state of development. They

are very active and nearly all are voracious herbivores. The nymphal period is one of extreme competition and during it the nymph must find safety, and get food sufficient for its entire life. With the exception of the Diptera, May-flies are the dominant aquatic insect herbivores. They have attained this position by utilization of a vegetable diet and by remarkable adjustments to particular situations. The population about them is divided into two classes, competitors and enemies. Their competitors are mostly insects, which, like the May-flies, live upon herbivorous or nearly herbivorous diet; among them are the larvæ of Caddis-flies (except the Hydrosychidæ), Crane-flies and most of the smaller Diptera. Their enemies are wholly or in part carnivorous. Important among them are the nymphs of Dragon-flies, Stone-flies, many beetles and the Hemiptera and Neuroptera. The adolescence of the nymph is evidenced internally by the development of the reproductive organs, and externally by the growth of rudimentary wings. This stage is terminated by a gradual change in organs of locomotion, respiration and digestion and by the final casting off of the nymphal skin.

The first winged or aerial stage is known as the sub-imago. The general form of body differs little from that of the actual adult insect. The wings are fully expanded and direct respiration through open spiracles is established. All surfaces are dull and in most cases the wings have a prominent marginal fringe of hairs. A few May-flies (females of *Palingenia* and *Campsurus*, Eaton '83) never lose the sub-imago skin, but in nearly all it is shed. The duration of the sub-imago stage varies from a few minutes in the most ephemereal species to several days. Needham,\* '08, has given this account of *Caenis diminuta*. "It is the most ephemeral of all Ephemera. It emerges from the water at nightfall, leaving its nymphal skin floating on the surface, and, alighting on the first support that offers, sheds its skin again, and the sub-imago stage is ended."

---

\*N. Y. State Bull. 124, p. 178.

The following data upon some of the longer lived species shows its average length:

Heptagenia interpunctata	♂	2 days = length	of sub-imago	life		
"	"	♂ 1 " = "	"	"	"	"
"	"	♀ 1 " = "	"	"	"	"
"	"	♀ 1 " = "	"	"	"	"
Siphylurus alternatus	♀	2 " = "	"	"	"	"
"	"	♂ 2 " = "	"	"	"	"
Iron fragilis	♂	2 " = "	"	"	"	"
"	"	♂ ♀ 2 " = "	"	"	"	"
"	"	♂ ♀ 2 " = "	"	"	"	"

Sub-imagos are very inactive and in nature spend the day-time resting in the shade, often upon the under side of leaves near the stream from whence they emerged. In captivity they are just as inactive, but if confined in very narrow quarters, they almost invariably fail to transform successfully. During this stage the legs, especially the front ones, and setæ are elongated and the reproductive system matures.

That this sub-imago stage is peculiar to May-flies is a well known fact. Little light, however, has been thrown upon its actual significance and analogy to the stages of other orders. Boas, '99, suggested that the sub-imago stage once had a wide distribution among Orthoptera which have now died out; that this corresponds to the pupal stage of holometabolous insects; and that the Ephemeridæ show a transition toward perfect metamorphosis. He believed that there was nothing in the form of Neuropterous pupæ which contradicts the theory that they have been developed out of such sub-imago stage.

The single molt of aerial life is followed by the mature or imago stage. At the beginning of this stage the eyes, legs and setæ attain full size. All surfaces of the body are shiny and the wings are transparent. The duration of this, like the sub-imago stage, varies greatly with the species. It varies also with the individual. Males which have mated are said to live a much shorter time than those kept in captivity.

Imagos are usually active at special times. Those of diurnal species fly freely at all hours of the day, but oftenest are seen in mating flights during the late afternoon. The nocturnal

May-flies must swarm in like manner at night is testified by the great numbers often caught in webs in the early morning. The important functions of this stage are the fertilization and laying of the eggs.

#### IV. MODIFICATIONS OF STRUCTURES OF THE NYMPH.

Nymphs of Ephemerinæ and Heptageninæ (Needham) live fairly within the limits of two ecological situations. The Ephemerinæ inhabit mud or muddy water exclusively. Most of the Heptageninæ live in riffles of streams or upon the wave washed shores of lakes. The Bætinæ inhabit gentle currents or open waters and intermingle with the mud and cascade dwellers as well. They have become adjusted to very different situations and they show a wide range of specialization.

All of the Ephemerinæ which have been found here live in the same situation and are very similar in their habit of life. Ephemera and Hexagenia are true burrowers in the mud; Polymitarcys occasionally adopts the digging habit and Potamanthus crawls upon silt covered stones and muddy bottoms in the same locality.

The members of the Heptageninæ are also very homogeneous habit. They live in running water, clinging or moving about upon the under sides of stones. Iron and Epeorus dwell in the swiftest water of the current, in riffles and falls; Ecdyurus and Heptagenia live in the gentle currents along the borders of the stream and sometimes beneath the stones in quiet pools.

The Baetinæ dwell in a variety of situations. Siphylurus and Callibaetis clamber upon the aquatic plants or dart about on the alga covered bottoms of still pools and inlets, while Ameletus more often frequents moving waters and nymphs of Blasturus hide among decayed leaves in ponds and brooks. Leptophlebia and Habrophlebia cling closely to the surface of stones, usually upon the under side and often in fairly rapid water. Most members of the genus Ephemerella have a similar habit, but there is a wide divergence among the species of this genus. Two genera, Baetis and Chirotonetes, are dwellers in water falls, and the latter has become remarkably well adjusted to its habitat. Tricorythus and Caenis are adjusted to life in mud and sand and show structures especially well fitted to their surroundings. These two extremes of

specialization are examples which show the variety of adjustments within this family. As later discussions will point out, they also show what diverse structures may fit an organism equally well for life in the same of similar situations.

Since the outside of an animal is the first to be influenced by environment, the most important adjustments must be looked for in external structures. In this study only the three most important sets will be considered; those which have to do with respiration, food and motion.

#### SHAPE OF BODY IN THREE SUBFAMILIES OF MAY-FLIES.

Before attempting to trace the adaption in the three systems just named, it is necessary to briefly describe the general shape of the nymphs in the three subfamilies.

The bodies of the Ephemerinæ are elongate, more or less cylindrical and tapering at either end. Those of *Ephemera* (Pl. XLIV, Fig. 8) and *Hexagenia* are almost perfectly cylindrical. The heads are wedge-shaped with the mandibular tusks projecting sharply in front. The bodies of *Polymitarcys* and *Potamenthus* (Pl. XLIV, Fig. 7) are flattened. The head of the latter is short and broad with the mandibular tusks barely showing beyond the labrum. A comparison of *Ephemera* (Plate XLIV, Fig. 8), with *Potamanthus*, will immediately show *Ephemera* to be the burrower.

In the Heptageninæ, the head, the body and all its appendages are depressed. In *Iron* and *Epeorus* (Pl. XLII, Fig. 4), which inhabit the swiftest water, this depression is greatest, but in *Heptagenia* and *Ecdyurus*, it is also very pronounced.

The form of the Bætinæ is various. The most representative is the slender compressed body and rather small rounded head which is characteristic of the active nymphs like *Callibætis*, *Ameletus*, (Pl. XLIII, Fig. 5 and Pl. XLII, Fig. 3). All of these nymphs have long legs for running and jumping, but in another type, the body is shortened, more or less flat upon the ventral side, and thickened through the metathorax. Such a form is represented by the majority of the Ephemerellas. It is most marked in the very short stubby bodies of *Cænis* and *Tricorythus*, which have become exclusively mud dwellers. In *Blasturus* (Pl. XLII, Fig. 1) there is a tendency to a depressed form. This is more pronounced in *Choroterpes*, which is strikingly similar to the Heptageninæ.

ADJUSTMENT TO ENVIRONMENT SHOWN IN THE STRUCTURE OF  
THE GILLS.

The gills of May-flies are especially susceptible to modification by the character of their surroundings. They are usually large and prominent. In other aquatic insects gills are less directly exposed. Those of stone-flies are generally tucked behind the legs upon the ventral side of the thorax, and those of damsel flies at the hind end of the body. Most May-flies have seven pairs of gills, one borne at each postero-lateral angle of the first seven tergites. They are usually large, sometimes unweildy and always a conspicuous feature of the body. Situated as they are, they extend along the whole side of the abdomen and brush against everything with which it comes in contact.

The gills of *Leptophlebia* are the most generalized of any which have been examined. They appear to lack modifications both for respiration in any particular situation or for protection. The seven pairs are identical in shape and nearly so in size. Each one is entire at the base, but deeply cleft into two long narrow divisions which lie in one plane. Their surfaces are without markings or local thickenings. One large trachea enters the gill and sends a branch to each of its divisions. In these there is but a scanty supply of tracheoles. The attachment to the abdomen is exposed above and below so that the only protection for the gill is in the ease with which it may be detached and regenerated.

In *Blasturus* the first pair of gills are like those of *Leptophlebia*, but the other six pairs are broadened so that a much greater respiring surface is provided. At the base a trachea enters and splits once, but each arm gives off a good number of branches which supply the whole surface of each gill division or lamella. The two lamellæ do not lie in the same plane, but the outer one is twisted over at the base and lies on top of the inner. A double gill made of two overlapping lamellæ is thus formed. A variation of this same kind of development is shown in the gills of *Choroterpes*. These gills have neither ribs, nor bands upon their margins. In consequence of this they hang limply from the sides of the body, but the main tracheæ provide some leverage for the muscles, and the gills

can be moved a little. The breathing movement is, however, slow and feeble. The nymphs are thus provided with large breathing organs, but also burdened with an unweildy load.

In *Siphurus* the gills are double and are stiffened by strong tracheæ and moved by muscles at the base, so that they can be held upright and can also be vibrated with great rapidity. In addition there are narrow spinous bands upon the inner sides of the upper lamellæ. Those of *Callibaetis* (Pl. XLIII, Fig. 5), are held in upright position, and can be rapidly vibrated like those of *Siphurus*. They are much smaller and lie farther dorsad when pulled down close to the body. They are better protected because less conspicuous, and better breathing organs because their rapid vibration enables them to absorb as much oxygen as if they were broad and bulky.

In the gills of *Baetis* the marginal bands are hardly indicated, but those of *Ameletus* are broadly bordered by thick spinous bands of chitin. In them the single lamella is fairly supplied by tracheæ. Its base is inserted into a shallow notch in the posterior margin of the tergite. Its attachment is thus slightly protected and at the same time it is allowed to swing freely. Adjustment to the conditions in water falls is always marked by an increase in the tracheal supply. - In *Chironetes* (Pl. XLVI, Fig. 13), this has been made by a great increase in the number of fine tracheoles which supply the lamella and by the development of a fimbriate gill at the base main trachea of which is a branch of the main trachea of the lamella. The margins of the lamella are bordered with thickened spinous bands similar to those of *Ameletus*, but it has also a stiff rib extending from base to tip.

A second group of *Baetinae* in which the gills are much specialized includes those which have been adjusted to an environment of mud and sand. Nearly all of these nymphs have the number of gills reduced. In *Ephemerella excrucians* there are but five pairs of gills and these cover but two abdominal segments. The attachments are in every case protected by lateral spinous extentions of the abdomen. In *Ephemerella rotunda* and *E. excrucians* a wide hollow shelf is formed from these spines, upon which the gills rest. Each gill consists typically of a thickened lamella, which completely overlies the delicate fimbriate-lamelliform division beneath.

The thickening of the upper lamella is greatest upon the front gills. This thickening and the reduction in number of the gills is most marked in the two mud dwellers, *Caenis* and *Tricorythus*. In these, gills are present upon segments two to six only. In all species of both genera the upper lamella of the first gill is modified into a cover which conceals all of those behind it. They are further protected by a shelf-like extension similar to that just described in *Ephemerella*. In the slight concavity of this shelf lie the delicate gills of segments 4, 5, 6, protected from the harsh gravel through which the nymphs crawl. When breathing actively the stiff covers are raised enough to allow water to circulate upon the gills beneath, which vibrate freely and create a current.

The gill covers of *Tricorythus* are scoop shaped, with the concavity beneath, so that even when the cover is closed down the gills are not under pressure, but are enclosed in a protecting box. The edges of the cover and those of the gills beneath are margined with short hairs. This brush of intermingled hairs makes an effective sieve which strains out particles of mud from the incoming current of water. Entrance of water at the base of the gill is prevented by a small triangular extension of the second abdominal segment which fits closely to the inner side of the elytroid cover.

#### *Gills of the Ephemerinæ.*

The most homogeneous series of gills is found in the *Ephemerinæ* which in Fall Creek were represented by *Potamanthus*, *Polymitarcys*, *Ephemerella* and *Hexagenia*. They are single and rudimentary upon segment one, (Pl. XLIX, Fig. 27) and double upon segments 2-7 (Pl. XLIX, Fig. 26). They are long and generally narrow, but this varies slightly with the genus. The upper and lower lamella are both fringed with filaments into which run branches of the tracheæ. The attachments are not protected and the base of the gills appears to be an unbroken continuation of the body wall, which is very flexible and tough. The gills of *Potamanthus* (Pl. XLIV, Fig. 7) are the most generalized. They are nearly linear, lie limply extended from the sides of the body and except for the scanty fringe of filaments are almost identical with the gills of *Lep-  
tophlebia*.



In the true burrowers, *Ephemera* (Pl. XLIV, Fig. 8) and *Hexagenia* (Pl. XLIX, Figs. 26, 27) both lamellae are broader and the number of the marginal filaments is more than doubled. Each lamella is stiffened by a mid-rib of chitin which overlies the main trachea. By the aid of this rib the gills can be held up over the back where they are not exposed to the constant friction as they would be when trailing from the sides.

#### *Gills of the Heptageninæ.*

The gills of the Heptageninæ (Pl. XLV, Figs. 10, 11, Pl. XLVI, Fig. 12) show a series of slightly less homogeneous adjustments. They are fitted for breathing in different degrees of rapid water, and at their maximum specialization, they are important aids to the nymph in clinging to surfaces. The gills are double except the last one which in *Heptagenia* is rudimentary. (Pl. XLV, Fig. 10). The upper division is plate-like and shows greater modification and the lower part is fimbriate-lamelliform or fimbriate, and varies slightly in size and position among different genera. The gills of the *Heptagenia* and *Epeorus* have the characteristic abundant tracheation of swift water inhabitants. In *Epeorus* the lamellæ are large, richly tracheated and lie obliquely recumbent along the sides of the body, (Pl. XLII, Fig. 4), so that the tips and outer edges touch the surface upon which the nymphs rests. Along this edge is a chitinized band thickly beset with spines. When clinging to stones in the rapid current this edge is pressed tightly down to the surface. The bases of the gills are protected by sharp extensions of each tergite, which project backward over them. On the inner margin of each lamella near the base is a shallow notch. When the lamellae are held close to the body the fimbriate gill projects through this notch and receives the full wash of the water. The first pair of lamellae are scoop-shaped and curve inward back of the hind legs so that little water flows beneath the body.

In *Iron fragilis* there is a similar, but more perfect adhesive apparatus. The outer margins of the lamellae are likewise banded and their position is identical with that just described. The first pair of lamellae are much larger, (Pl. XLVI, Fig. 12), and their tips are held almost in contact. The last pair are folded and slightly curved so that the tips of these also nearly touch. When the margins of these lamellae are closely pressed

against the surface a sucking disk is formed. In the lamellae and in the fimbriate gill above, the tracheae absorb oxygen from the water constantly flowing over them. An adhesive apparatus is thus coupled with an efficient respiratory organ.

*The Food of the May-fly Nymphs.*

May-flies are almost entirely herbivorous. Their food consists chiefly of fragments of higher plant tissue, algæ and diatoms. The following table contains the record of an examination of the stomach content of several nymphs. With the exception of Siphilurus and Chironetes the examinations were made upon fresh material:

STOMACH CONTENTS OF NYMPHS EXAMINED THROUGH APRIL AND MAY. CROSSES (X) REPRESENT SUBSTANCES FOUND IN MORE THAN TEN SPECIMENS OF A GENUS.

	Siphilurus	Heptagenia	Blasturus	Hexagenia	Callibaetis	Chironetes
1. Fragments of Plant Tissue.						
Stems, decayed leaves.....	X	X				
Epidermis.....	X	X				
Epidermis, moss.....	X	X				
Epidermis, roots.....						X
2. Filamentous algæ.						
Vaucheria.....	X					
Spirogyra.....	X				X	
Mougeotia.....	X					
Ulothrix.....	X					
Zygnema.....	X				X	X
3. Diatoms.						
Navicula.....	X	X		X		
Fragellaria.....	X	X	X			
Tabellaria.....	X	X				
Coconema.....		X	X	X		
Meridion.....			X			
Gonphonema.....			X	X		X
Synedra.....						
4. Animal.						
Mayflies.....	X					X
Other insects.....						X

The kinds of algæ and diatoms found in the stomach varied a good deal with the locality and date of collection. In certain parts of Cold Brook during March, 1911, every available object was brown with Meridion and the stomachs

of nymphs collected there contained little else. Nymphs taken in the same place a month later contained no fragment of Meridion. May-fly food is most abundant in April and May, especially for the running water forms. Later the thick mats of Meridion, Cladophora and Spirogyra begin to decay, there is a diminished supply of water and consequently greater competition for food.

In the summer of 1911, a few experiments in feeding were made upon *Callibaetis fluctuans*, one of the most abundant local May-flies in pools and open waters. Six pails about one foot deep and seven inches in diameter were made from strong muslin. A ring of wire was placed at top and bottom to extend them. A string was tied into the upper one for a bale and the pails were fastened to a frame and suspended in a pool where the water was kept constantly fresh. They were numbered 1, 2, 3, 4, 5, 6, and a different food placed in each respective pail.

On June 28, twelve nymphs of equal size were measured and freed in pail. On July 1, nymphs were taken from each pail and the stomach contents examined. For ten days more the same food was given at intervals of two days. Occasionally the pails were rinsed free of stale food. This was especially necessary for the corn meal which soured quickly.

June 28 12 Nymphs in each Pail	July 1 Alive	July 1 Stomach Content	July 10 Alive
1. Fruiting chara.....	All	Not much food, fragments chara.....	All
2. Corn meal.....	All	Half full of meal.....	6
3. Alfalfa (ground).....	All	Not much food, fragments alfalfa.....	9
4. Spatter-dock (ground)....	None	Full of spatter-dock tissue....	-
5. Green grass (ground).....	7	Half full, green grass.....	7
6. Fruiting chara (control)...	All	Full of chara.....	All

### *The mouth-parts of May-fly Nymphs.*

#### *Bætinae*

The most generalized mouth-parts occur among the *Bætinae* in the species which bite or tear fragments from roots and stems. They consist of labrum, labium, mandibles, maxillæ, hypopharynx, and the epipharynx which is borne upon the labrum. Those of *Callibaetis fluctuans* (Pl. XLVII, Fig. 14),

are typical of this generalized condition. On the concave inner surface of the labrum are two patches of incurving hairs, and these are supplemented by a set of long marginal hairs. When gathering food the edge of the labrum is pressed against a stem or leaf and moved rapidly back and forth. After a few movements its tip is pulled close to the mouth and brushed by the maxillary palpi. The labium sweeps food in from behind as the labrum does from the front. On the maxillæ which lie in front of the labium the lacinia and galea are fused. The lacinia is represented by two teeth on the tip; the galea by the lobe like part behind them. The teeth of mandibles are separated into two distinct groups, the canines (c) and the molars (m). In many cases both of these are very asymmetrical. Both maxillæ and mandibles may be freely extended side wise, but the latter is used less often for biting than for grinding. The epipharynx (cf. Pl. XLVII, Fig. 14b) is an inconspicuous elevation which is borne on the inner surface of the labrum. It is densely covered by short incurved hairs probably sensory. It often extends on to the clypeus and in all the nymphs examined lies a little to the right of the center. Mouth-parts of the type described above are found in nymphs of *Siphylurus*, *Blasturus*, *Baetis* and *Leptophlebia*. The food getting habits of any of these can be easily observed. They pull off fragments from the stems and leaves by sticking the lacinia or less often the canines into the tissue, then bracing with the front feet and pulling backward. Upon flat surfaces, they keep the labrum and labium moving rapidly and thus sweep the food into the mouth.

In nymphs of *Ameletus ludens* a broad plankton rake upon the maxillae formed by a series of arched, regularly graduated, and pectinated hooks borne upon the distal end of the galea and lacinia. When eating, the nymph extends these rakes forward and backward, exactly as one would use a hand rake and by the help of the labium and hypopharynx the food is pulled into the mouth for grinding.

Nymphs of *Chirotonetes* gather their food upon ledges washed by dashing water. The outer surfaces of the mouth parts are armed with very long bristles. The distal segment of the labial and maxillary palpi are flattened out into broad blades. These blades are used as scrapers upon the algæ covered stones. In the swift current this nymph must of necessity

cling to the rocks with its head upstream. In doing this it uses its fore legs little, but they are held up and straight forward close beneath the labium. Armed with long bristles as they are, they help to form an efficient plankton basket which catches the food carried along in the water.

In *Caenis*, *Tricorythus* and *Ephemerella* the mouth-parts are often reduced. In all these the mandibles are stout with very strong canines (Pl. XLVII, Figs. 16, 19, and Pl. XLVII. Figs. 20, 21). Structures like the palpi which extend out from the mouth are much shorter. In *Tricorythus* (Fig. 22), the body of the labrum is strong, but the palpi are weak and stubby. This reduction is carried to the limit in the maxillæ of *Ephemerella deficiens* in which the palpi have disappeared, leaving only a little peak of chitin at their attachment place (Fig. 18). If one observes nymphs of *Tricorythus* or *Ephemerella* foraging, they will see them continually thrusting their heads through harsh gravel where such appendages would be in the way.

The *Bætinæ* have the most generalized mouth-parts examined. This group includes species in which there have been modifications of the mouth-parts for rakers and plankton baskets, and great reduction of palpi.

#### *Ephemerinæ*

Nymphs of *Potamanthus*, *Polymitarcys* and *Hexagenia* all gather their food in the same places and by the same means. Their relative specialization has been closely correlated with the extent to which they have been modified for burrowing. The mandibles of *Potamanthus* (Pl. XLVIII, Figs. 23 and 24) show the beginning of this modification. The canines are here in their usual position at the tip of the mandible (c), but upon the outer side of each is a stout pointed process. These processes are not long, and when the mandibles are in natural position only their tips show beyond the labrum. These processes are similar in shape and identical in position with the tusks of the true burrowers, *Ephemera* and *Hexagenia* (Pl. XLIX, Figs. 31, 36). In these the processes are long, slightly incurving tusks which are the most conspicuous features of the head. The canines are on the median side of these near the base, and when the mandibles are in natural position, they extend downward and can thus most efficiently grasp

food. From them the food is passed inward to the grinding surface of the molars. Upon the left molar (Pl. XLIX, Fig. 34) are eight deep transverse gutters. The upper ends of these are enclosed by irregular teeth and the floors are marked by transverse striations. The right molar (Fig. 35) surface bears seven overlapping ridges, all but one of which is bluntly toothed and enclosed at one end by a prominent jagged process. When in position the ridges of the right molar fit down into the gutters of the left and the terminal teeth fit into the free ends of the gutters. The food brushed into the mouth by the labium and maxillæ is ground in this mill.

In the Ephemerinæ the greatest modification has occurred in the mandibles which have become the strongest structures of the head, important alike to feeding and burrowing.

#### *Heptageninæ.*

In the Heptageninæ which have scraping mouth-parts, the labrum is entirely hidden from above. It is freely movable upon the clypeus and has a row of very dense, slightly incurved hairs extending along its margin. The inner surface of the labrum is slightly concave, and bears the epipharynx. When the labrum is extended forward the short hairs upon the inner surface rake in the food and are closely followed by the thick brush upon the margin. Food thus gathered in the concavity of the labrum falls directly between the maxillæ and mandibles.

#### *Legs of Nymphs.*

The legs of May-fly nymphs consist of a coxa, trochanter, tibia, tarsus and a tarsal claw. These parts vary in relative size and structure according to the habit of the nymph. The surfaces may be bare, scaly, spinose or hairy. In all of the legs which have been examined there is a small but distinct plate on the inner side at the distal end of each tibia.

#### *Bætinaæ.*

The Bætinaæ includes nymphs which have the most generalized legs, such as those of Siphylurus, Callibætis, Ameletus and Chirotonetes. All of these nymphs can move about upon a heterogeneous footing (Figs. 3 and 5). The legs of Siphylurus are of the most generalized type. They are long and slender and the three pairs are of equal length. The surfaces are sparsely covered with inconspicuous hairs. The tarsal claw

is long, slender and without teeth. The tibial plate is well developed, consisting of a thick, flattened projection of the tibia, which bears transverse ridges. The attachment of the legs allows free movement and the nymphs are capable of running very swiftly. The middle and hind legs of *Chironetes* are similar to those which have been described, but the first pair has been modified for food gathering and respiration. At the base of the coxa, there is a large tuft of forked gill filaments. From the tibia an elongate flattened spur extends for more than half the length of the tarsus, and along the inner margin of femur, tibia, and tarsus is a regularly arranged row of very long, stiff hairs. When the legs are sharply bent, these hairs, together with the tibial spur form the bottom of the plankton basket already referred to.

In *Cænis*, *Tricorythus* and *Ephemerella* the legs do not lift the bodies at all. Nymphs of *Cænis* and *Tricorythus* clamber upon very uneven surfaces so that the legs do not extend straight out from the body as they do in some of the *Ephemerellas* later noted. The strain of pulling and climbing comes evenly upon every segment of the leg and there is little difference in their size. In both of these genera the tarsal claws are in constant use and are correspondingly well developed. The same evenly distributed development may be seen in the legs of certain *Ephemerellas*, which constantly crawl over mud, dead leaves, and small debris. In others in which there are well established clinging habits (Pl. L, Figs. 39, 43), the fore femora are enormously developed by the constant pulling incident to their position. In these legs the hinder part of the femora is greatly thickened by the muscular development, but the front edge is thin and blade-like and often jaggedly toothed or serrate.

#### *Ephemerinæ.*

Two stages of modification are shown in the legs of *Potamanthus* and *Ephemera*. In *Potamanthus*, which crawls upon the bottom in a manner similar to the *Heptageninæ*, the legs sprawl out from the body in the same way. The tibia is prolonged into a flat spine which overlaps the first third of the tarsus. The structure of this fore leg appears to be the fore-runner of the greater modification shown in the fore legs of *Ephemera*, (Pl. XLIV, Fig. 8), which are perfect digging tools.

## V. MODIFICATIONS OF ADULT STRUCTURES.

Reproduction is the sole end of the imago life. Parts of the body which have no function connected with it are reduced or atrophied.

It is probable that, with but few exceptions, May-flies engage in some kind of mating flight. The character of this flight and the time when it occurs vary. The following records show some of these variations. On June 25th a swarm of three or four hundred individuals of *Choroterpes basalis* were swarming over the water of Fall Creek at about four o'clock on a sunny afternoon. Their average rise must have been thirty feet. From the swarm both males and females were captured, but mating was not observed. On June 29th, at 7:30 in the evening, a female *Ephemera varia* was captured from a swarm which was rising and falling in flights of thirty to forty feet. Often they descended to within five feet of the ground. Their dance continued until darkness hid them. Mating flights of *Leptophlebia præpedita* have been seen in the middle of a sunny forenoon, and at two, four and five o'clock of bright afternoons in May and June. None of these rose higher than fifteen feet and two of the swarms did not fly more than six feet above the ground. One entire swarm which was captured contained forty males and one female.

Actual mating has been observed but a few times. The most satisfactory observation was made in May, 1911, upon a swarm of *Bætis*, which were flying near Cascadilla Creek just after a shower. Most of the time they were not flying much above the level of the eye so that they could be clearly seen. Large numbers continually settled on bushes and upon my clothing, and there appeared to be about equal numbers of males and females. Many matings occurred, but in only seven could the positions of the insects be seen at all. The male of one of the couples flew up and attached himself beneath a female, pressed the dorsal side of his head against the ventral side of her thorax and extended his fore-legs upward, in order to clutch her prothorax. The setæ of the female extended straight out posteriorly, but those of the male were pointed forward over his back so that their tips projected between the heads of the two insects. The position of the abdomen could not be clearly seen, but judging from that of the setæ, it



must have been recurved in order to insert the penes inside the egg valve. Copulation did not last more than half a minute. When in copula, each pair was borne diagonally downward to the ground, but always separated immediately upon touching it.

So far as known flight is a necessity for copulation and egg-laying in May-flies. The alimentary canal and the legs play a part in flight which is peculiar to this group. It is a well known fact that adult May-flies take no food and that the alimentary canal is inflated with air or gas. Sometime before emergence the nymphs cease to eat and just before it, they push their heads above the surface and appear to be rapidly gulping in air. If dissected at this stage the alimentary canal is found much inflated. It remains thus inflated throughout life. The structure of the alimentary canal of adults was studied by Fritze, '06 and by Sternfeld, '07. Sternfeld found a complicated muscular dilator apparatus in the esophagus. This he concluded to be a pump by which the mid-gut was filled with air and by which its supply could be voluntarily controlled. He did not discover whether any change occurred in the air taken in. No suggestion was made as to when this pump was used, but it is probable that it functions when the canal is first inflated by the nymph and afterward in controlling the specific gravity during flight. This change of the alimentary canal from its normal function to that of a balloon is very important to flight. The lessening of the specific gravity made possible by this modification makes the work of the wings much easier. Since it is more important that adults mate, than that they live a long time, this function of the alimentary canal exceeds the former one in value.

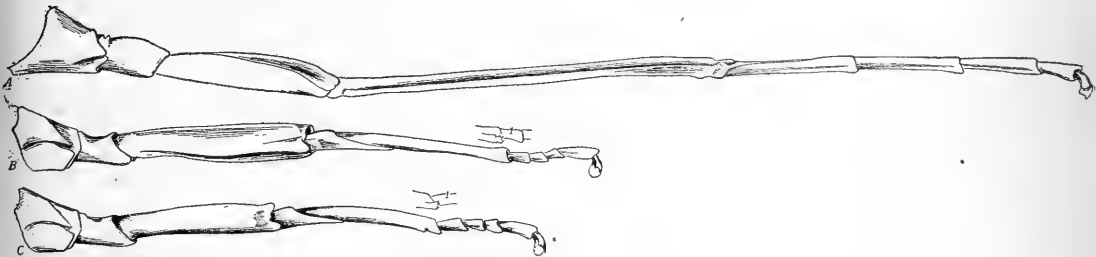

Fig. 1. Legs of male imago of *Hexagenia bilineata*. A, first leg; B, second leg; C, third leg; 1, opposite side of legs showing tibial spur.

It has already been noted that adult May-flies use their legs little or none in walking and in many instances the fore legs are not even used for support. In most males the fore legs are enormously lengthened and when the insects are at rest, they are often extended out from the head (Pl. XLIV, Fig. 9). The middle and hind legs brace the body, but they usually lift only the front part, while the abdomen rests upon the supporting surface (Pl. XLIII, Fig. 6). The fore legs are necessary structures in copulation and males of *Palingenia* which have very short legs mate not in mid-air, but close to the surface of streams. (Eaton). The legs of some May-flies have been enormously specialized. The fore-legs of a South American *Campsurus* are very long, (see Fig. 3), while the middle and hind ones are but short stubs. In the fore legs there is a twist in

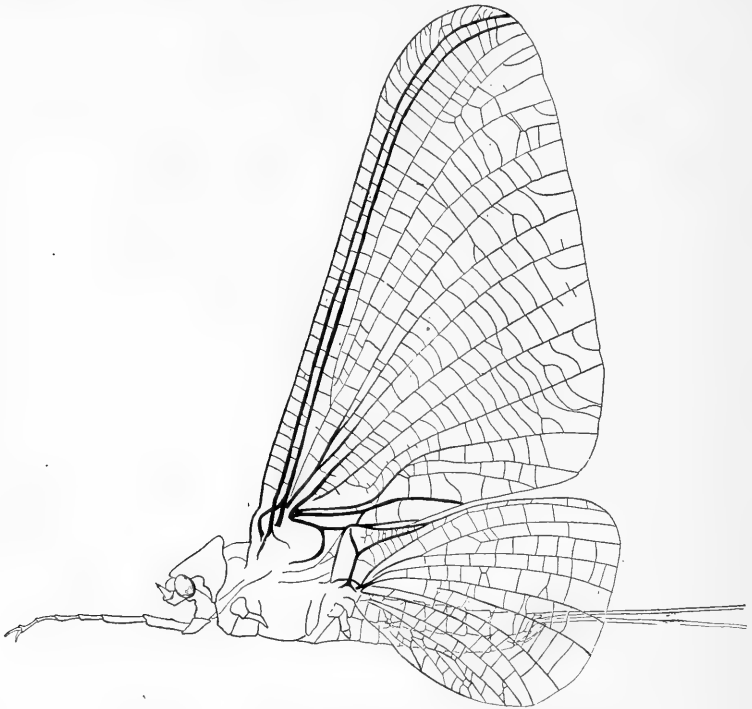

Fig. 2. Male imago *Campsurus* (South America) showing rudimentary middle and hind legs. The setæ not represented at full length here, are about three times the length of the body.

the joint which articulates the tarsus with the tibia. This admits the supination of the tarsus and is evidently a modification for clutching the female.

*External Genitalia of the Male.*

The external genitalia of the male consists of a pair of forceps, jointed except in *Cænis* and *Campsurus*, and two penes, each with a distinct opening. The forceps are incurved appendages of the tenth segment, by which the male grasps the abdomen of the female. The genitalia of *Hexagenia*

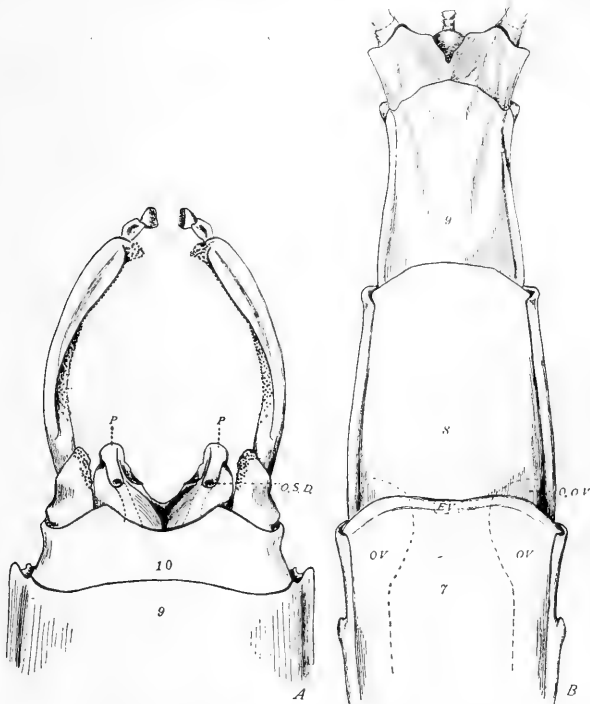

Fig. 3. A, external genitalia of *Hexagenia* sp.? ♂; p, penis; o. s. d., opening of seminal duct; f, forceps. B, ventral view of rear abdomen of *Hexagenia* sp.? ♀, showing ov, outline of oviduct seen through body-wall; o. dv., opening of oviduct; e. v., egg-valve; 7, 8, 7th and 8th sternites.

sp.?\* are of the simple type. The forceps are three jointed, with a stout basal piece. The two distal segments are concave on the inner surface and tip. These concavities, the flap like extension upon the main segment and the inner surface of the basal piece are thickly covered with small papillæ, which are characteristic of nearly all forceps examined. The roughened surface produced by them probably

This is a species *Hexagenia recurrata* in manuscript which I have to be published.

helps to hold the female. The penes are the intromittent organs. In *Hexagenia* they consist of two chitinous funnels whose larger ends open inside the body, and whose smaller ends are slender tubes bent down ventrally. Between the penes is a thin chitinous plate, and beneath they are supported by the tenth sternite. In each penis the seminal duct can be clearly traced to its termination at the end of the bent tube.

Of the more complicated condition which exists in most May-flies, the genitalia of *Siphilurus alternatus* is fairly typical (Pl. II). The forceps are similar to those of *Hexagenia*. Their origin from the ninth sternite is shown in Figures 48 and 49. The penes (P) are wholly hidden from beneath by the tenth sternite, but they are attached only at their bases, and in copulation may be freely projected within the (Fig. 50, EV) egg valve, while the tenth sternite remains outside it. Essentially they consist of the funnels just described in *Hexagenia* with secondary structures added. The larger ends of the funnels open into the body (Fig. 49, A). In Figure 49 the penes are shown in dorsal view, separated off from the dorsal part of the abdomen with the large ends of the funnels exposed (A). The small end of the funnel (B) extends outside the body and turns downward as in *Hexagenia*, but the opening of the seminal duct is enlarged and trumpet-shaped. From the dorsal side only the backs of these trumpets can be seen, but when the penes are completely removed from the ninth sternite and turned with their ventral sides up, one can look directly down into their openings, (Fig. 52, O. S. D.) and the seminal ducts can be traced from the testes directly to them. Lying dorsal and lateral to each seminal tube are two prominent, heavy chitinized processes (Fig. 49). The raised apex of the upper process (C) is pointed toward the middle, that of the lower (D) is pointed outward toward the side and the prominent spines upon each are directed in different directions. If the supposed position of the penes in copulation, be correct, the dorsal or spinose surface of these processes must be in contact with the inner surface of the egg valve (E. V. Fig. 50). When inserted they would thus hook over its soft lip and pull it down, allowing the seminal tubes to discharge their contents at the mouth of the oviducts.

*Genitalia of the Female.*

In the simple condition each oviduct lies well to the side of the abdomen and opens between the seventh and eighth sternites (Hexagenia). Each opening is perfectly distinct (see dotted line Fig. 3, B) and there is no sign of an open passage or vestibule between the two.

In *Siphilurus alternatus* (Pl. LI, Figs. 53, 55) the lower ends of the oviducts approach each other and open into a common vestibule (C. V.) just inside the egg valve. Opening into this vestibule is a soft membranous sac (S. R.). In fresh specimens this sac shows prominently between the bases of the oviducts (Figs. 53, 55). In figure 55 the sac and oviducts are shown viewed from the inside; the nerve chain has been severed so as to fully expose the sac. In the specimens thus far examined, no spermatozoa have been found within this sac. It is extremely probable, however, that this is a true seminal receptacle, and that this is a specialization which nearly approaches the unpaired opening found in other insects.

## VI. THE EGGS.

Under the ordinary conditions of their life a large proportion of May-fly nymphs regularly perish before reaching maturity. A great excess of young must be produced in order to meet this loss and the success of different groups in maintaining their existence becomes more than usually dependent upon the number of eggs produced and the structures which aid in their dispersal and safety during incubation.

In insects whose lives are so brief as these, the eggs are well developed even at emergence, and may then be readily counted, the difference in size between the developed eggs and the egg rudiments being very marked. It is easy, therefore, in mature nymphs, sub-imagos or imagos to determine the actual fecundity.

The first count of May-fly eggs was made by Reaumur\* to determine the fecundity of some specimens which he captured in his garden. He found egg masses protruding from the abdominal openings, counted the eggs and found about 400 in each mass. His results have been several times quoted by later workers, but no references has been found to any

\*Reaumur 1742. T. VI, Mem. XII, p. 495.

other actual determination of the fecundity of May-flies since that time.

In this study the eggs of seventeen May-flies have been counted and examined. They were taken from imagos which had been kept in cages until they showed signs of old age. Usually a count was made of the eggs in several individuals and an average taken. They were examined and counted upon a glass slide in a mixture of water and glycerine which formed a convenient medium in which to manipulate them. The results of the counting are given in a table which follows.

All of the eggs are viscid. When laid in dishes they adhere to the bottom, as do those of *Bætis* to stones. When twigs or algæ are introduced, they become attached to them. There are two kinds of structures found upon them; micropylar structures and knob or thread-like extensions of the chorion, both of which are important to the egg; and there is also a variety of chorionic sculpturings which have no apparent significance.

Examples of the more important structures were long ago pointed out. Polar knobs (micropylar structures) were figured by Burmeister '48, and described by Leuckart '55. The latter believed that the knobs were composed of masses of spermatozoa and it remained for Grenacher, '68, to find many stages of them upon developing eggs in the egg-tubes and to point out their true nature. Micropylar structures were also shown in *Palingenia virgo* by Joly, '71 and '76, and in *Bætis sulphurea* by Joly, '76. Grenacher, '68, also pointed out (upon an unnamed May-fly egg) some little threads which were continuous with the chorion and which bore tiny spheres upon the ends. He figured these with remarkable accuracy. Of the eggs here figured, three bear a micropylar apparatus, five have thread-like extensions of the chorion and nearly all are more or less elaborately sculptured.

The eggs of closely related forms may be very different. This is well shown by a comparison of those of *Ephemerella excrucians* and *E. rotunda* (Pl. LIV, Figs, 66, 67). The eggs of *Ephemerella excrucians* are pure white, and slightly dumb-bell shaped, with a distinctly sculptured chorion, but with no micropylar apparatus. Those of *Ephemerella rotunda* are yellowish and oval with a prominent mushroom shaped cap about the micropyle. If examined in the body or when first extruded, two small knobs may be seen upon either side of the egg, near its lower pole. Each knob is attached to the

distal end of a thread-like extension of the chorion, which lies beneath it, tightly coiled like a watch spring. Upon coming in contact with the water these threads spring out like elaters. The little knobs thus extended probably act as floats or anchors for the egg. An even greater difference between the eggs of closely related forms may be seen in the eggs of *Heptagenia interpunctata* (Pl. LIII, Fig. 65) and *Heptagenia pulchella* (Fig. 64). The former has a pure white oval egg without sculpturings or extensions of any kind. The latter is white and slightly rounder with small regularly arranged bosses upon the chorion. At each pole there is a skein of fine bright yellow thread. These skeins are also prominent upon the poles of developing eggs, even in the tips of the egg-tubes. Upon a glass slide they are easily seen with the naked eye and the threads may be pulled out with needles to a length of two or three inches. As soon as the eggs float free in water the skeins begin to unroll and if shaken a little they quickly uncoil altogether and become entangled with any object near them. In nature the eggs are deposited upon the surface of moving water. The threads just described probably wind about sticks or plants and thus anchor the eggs and keep them from being buried with silt during incubation.

Similar extensions of the chorion are found upon the eggs of *Tricorythus allectus* and *Ecdyurus maculipennis*. The eggs of *Tricorythus* (Pl. LII, Fig. 60) are bright green and oval with a prominent shingle-like surface. Upon each side of the egg toward the lower pole are two threads very similar to those of *Ephemerella rotunda*, but without any knobs upon the ends. At the other pole is a prominent smooth yellowish micropylar apparatus. The eggs of *Ecdyurus* (Pl. LIII, Fig. 62) are roundly ovate and pure white. Their entire surface is covered with minute pits and scattered between these are numerous short blunt projections. When the egg is first removed from the body, a small coil of thread may be seen in the depression on the top of each projection. As soon as the egg has been in the water a little while, each coil unwinds with a sudden spring. At the end of each thread is a tiny viscid button.

The eggs of *Leptophlebia* sp.? (Pl. LII, Fig. 58) are elongate ovoid, distinctly brownish and thickly covered with short hairs, so that they look like ciliated protozoans. Those of *Choroterpes basalis* (Pl. LIII, Fig. 63) which are laid in the same

or similar situations have no extensions of the chorion. They are pure white, elongate, with an elaborate design in the sculpturing. The eggs of *Blasturus cupidus* (Pl. LIV, Fig. 68) are slightly flattened and tablet-like. Upon these flattened areas are irregularly scattered pits and bosses which appear shining white in the glycerine and about the longitudinal circumference is a shelf-like extension which bears a large number of strap-shaped pegs. The eggs of *Polymitarcys albus* (Pl. LIV, Fig. 69) are roundly ovate and white. The body of the egg is nearly smooth, but the prominent yellow micropylar apparatus has a distinctly shingle-like surface. The eggs of *Callibaetis fluctuans* and *Chironetes albomanicatus* were perfectly smooth and pure white.

Nymphs of *Hexagenia variabilis* and *Polymitarcys albus* live in the same situations but the eggs of the former are only a little roughened, while *Polymitarcys* has the prominent micropylar apparatus just described. The roughness due to chorionic sculptures may be of some slight service in helping to lodge the eggs, but its significance is probably slight. The extensions of the chorion, on the other hand, are no doubt of much importance in the dispersal and safety of the eggs. The anchors upon *Ephemerella rotunda* and *Tricorythus allectus* hang the eggs upon sticks and stems and prevent them from being buried in the mud; the many viscid threads upon those of *Leptophlebia* and *Ecdyurus maculipennis* accomplish the same result in a different fashion. Those which probably have the most important function are the long threads upon the eggs of *Heptagenia interpunctata*. A number of these were shaken about in water strewn with chara and the threads immediately became closely entangled upon its stems. Eggs thus hung upon stems in natural conditions would be safeguarded and prevented from being buried in the mud.

	Number of egg in both ovaries	Color of egg	Length (Fresh eggs meas- ured in glycerine)	Width eggs meas- ured in glycerine)
<i>Ameletus ludens</i> .....	670	Light brown	.276 mm.	.153 mm.
<i>Blasturus cupidus</i> .....	3700	White	.177 mm.	.093 mm.
<i>Callibaetis fluctuans</i> .....	500	White		
<i>Chironetes albomanicatus</i> .....	2500	Pale green	.200 mm.	.138 mm.
<i>Choroterpes basalis</i> .....		White	.174 mm.	.085 mm.
<i>Ecdyurus maculipennis</i> .....	1000	White	.170 mm.	.133 mm.
<i>Ephemerella excrucians</i> .....	1950	White	.200 mm.	.125 mm.
<i>Tricorythus allectus</i> .....	750	Green	.189 mm.	.122 mm.



## VII. BIBLIOGRAPHY.

References are marked by asterisks.

1881. **Albarda**. Veth's Midden-Sumatra. IV. pt. 5, p. 12. (Rhoenanthus and Isonychia noted.)
1843. **Atkinson, John**. Notes on Ephemerae. E. Alipennis. Zoologist, London I. p. 272-275.
1900. **Banks, N.** New genera and species of Nearctic Neuropteroid Insects. Trans. Amer. Ent. Soc. XXVI, pp. 239-259.
1901. **Banks, N.** A List of Neuropteroid Insects from New Mexico. Trans. Am. Ent. Soc. XXVII, pp. 361-371.
1903. **Banks, N.** Neuropteroid Insects from Arizona, Ent. Soc. of Washington, V. pp. 237-245.
1903. **Banks, N.** Habrophlebia Americana. Ent. News, Philadelphia, Pa. XIV, p. 235. Fig.
1904. **Banks, N.** The Terms Plecoptera, Anisoptera and Ephemeroptera. Science, New York, N. Y., p. 155.
1907. **Banks, N.** A new May-fly of the genus Caenis. Ent. News, Philadelphia, Pa., 18, pp. 13-14. 1 Fig.
1908. **Banks, N.** Neuropteroid Insects (Potamanthus medius) Philadelphia, Pa. Trans. Amer. Ent. Soc. XXXIV, pp. 255-266.
1911. **Banks, N.** Notes on our Eastern Species of the Mayfly Genus Heptagenia. Canadian Entomologist, Vol. XLII, pp. 197-202.
1750. **Bartram, J.** Observations of Mayflies at Philadelphia. London Trans. R. Soc. XLVI, (abridged).
1791. **Bartram, William**. Travels through North and South Carolina, Georgia, East and West Florida. p. 18. Philadelphia.
1907. **Bernhard**. Cloeon dipterum, Biol. Centralbl. Leipzig, XXVII, pp. 467-479.
1903. **Berry, E. W.** New or hitherto unknown Ephemeropterid nymphs of the Eastern U. S. Amer. Nat., New York, XXXVII, pp. 25-31.
1899. **Boas, J. E.** Einige Bemerkungen über die Metamorphose der Insecten. Zool. Jahrb. Jena XII, Syst. pp. 385-402, Pl. 20, 3 Text Fig. (pp. 394-5 relates to Mayflies.)
1832. **Bowerbank**. Observations on the Circulation of the Blood in Insects. Ent. Mag., London, Art. XXV, pp. 239-244, Pl. II. (Circulation in Ephemera marginata Say.)
1882. **Brauer, Fr.** Über das Segment mediare Latreilles Wien Sitz. Ber. der k. k. Ak. Wiss. Mathem. Naturw. Klasse. Bd. 85, Mit 3 Tafeln.
1885. **Brauer, Fr.** Systematische zoologische Studien, Stiz. Ber. der k. k. Ak. Wiss. Math. Naturw. Klasse. Bd. XCI, p. 310. (writes indirectly of Ephemeropter wing-muscles. cf. Durken '07.)
1889. **Brauer, Fr.** Redtenbacher, J. and Gegenbauer, L. Fossile Insekten aus der Jura formation Ost. Sibiriens; mem. Ac., St. Petersburg Sc. (7) XXXVI, No. 15, pp. 1-22, pls.
1899. **Briggs, C. A.** Two species of Ephemeridae new to Britain, Entom. Monthly Mag., Vol. X, pp. 68-69. (Leptophlebia meyeri and Ameletus inopinatus).
1832. **Burmeister, H.** Handbuch der Entomologie, Bol. I, Berlin. (excellent resume of works preceding it.)
1841. **Burmeister, H. C.** Article "Ephemera" in Ersch & Gruber's Encyclopaide des Wissenschaften. Theil XXXV, pp. 312-16.
1848. **Burmeister, H.** Beitrag zur Entwicklungs geschichte der Ephemeren, Zeitung für Zoologie, Zootomie, und Palaeozoologie herausgegeben von E. D. Alton and H. Burmeister, Nr. 14, Bd. 1, s. 109-112, Taf. I, Fig. 20-24.
1889. **Calloni, S.** Noterelle entomologiche. Bull. Ent. Ital. XXI, pp. 39-49.
1848. **Calori, Aloys.** Sulla generazione vivipara della Cloe diptera. Nuov. Ann. Sci. Bologna, ser. 2, T. 9, pp. 38-53.
1893. **Carriere, J.** Kurze Mittheilungen aus Fortgesetzten Untersuchung über die Schorgen Zool. Anz. Leipzig, IX.
1835. **Carus.** Traite elementaire d'anatomie comparee.

1896. **Causard**. Sur un Ephémère vivipare. C. R. Acad. Sci. Paris, CXXIII, pp. 705-708. Translated in Ann. & Mag. Nat. Hist., (6) Vol. XVIII, pp. 480-482. Abstract in Amer. Nat. New York, Vol. XXXI, pp. 165-167.
1898. **Causard, M.** Sur le rôle de l'air dans la dernière mue des nymphes aquatiques. Bul. Soc. Ent. France, pp. 258-261.
1881. **Ciaccio, B. V.** Sopra la notomia minuta degli occhi della Cloe diptera, L. Rend. Acc. Bologn. 1881, pp. 79-81. Rev. Bull. Ent. Ital. XIV, p. 154. Rev. London R. Microscop. Soc. II, 1882, p. 609.
1896. **Ciaccio, G. V.** Degli occhi nei generi Potamanthus e Cloe della Famiglia delle Ephemeridae e come eglino sono composte intessuti. Rend. Accad. Sc. Bologna '95-96, pp. 91-95.
1906. **Cockerell, T. D. A. and Marie Gill.** Tricorythus, a Genus of May-flies. Univ. Colorado Stud., Boulder, Colo., Vol. III, pp. 135-137.
1908. **Cockerell, T. D. A.** Descriptions of Tertiary Insects. Amer. J. Sci., New Haven, Ct., Ser. 4, XXV, pp. 51-52, 227-232, 309-312.
1897. **Coggi, Allesandro.** Ancora sulla vivipaita di un efemera. Anat. Anz., Jena, XIII, No. 18, pp. 498-499.
1746. **Collinson, Peter.** Some observations on a sort Libella or Ephemeron. With Fig. London, Phil. Trans. R. Soc., Trans. XLIV, (abridged) pp. 363-366.
1748. **Cornelius, C.** Beitrage zur naheren Kenntniss der Palingenia longicanda Oliv. Elberfeld, Buschler.
1888. **Costa, A.** Notizie ed osservazioni sulla Geo. Fauna Sarda.  
 Memoria seconda, Atti. Acc. Nap. (2) i, No. 2, pp. 1-109;  
 Memoria terza, Atti. Acc. Nap., No. 9, pp. 1-64.  
 " 4 No. 13, pp. 1-31.  
 " 5 No. 7, pp. 1-24.  
 " 6 No. 8, pp. 1-40.
1885. **Creutzburg, C.** Ueber den Kreislauf der Ephemerlarven. Zool. Anz. Leipzig, VIII, pp. 246-248. Transl. in Ann. N. H. (5) XV, pp. 494-495. Abstract. J. R. Micr. Soc. (2) p. 637.
1834. **Curtis, John.** Descriptions of some nondescript British species of May-flies of Anglers. Lond. & Edinb. Philosoph. Magaz. Vol. IV, ser. 3, pp. 103-122. No. 20, No. 21.
- Dagliesh, Gordon.** Notes on the Common Mayfly (Ephemera vulgata) and other species. Zoologist, Vol. XIII, pp. 264-269.
1835. **Davis, Abraham H.** Metamorphosis of Ephemera. Ent. Mag. II, pp. 322-323.
1748. **DeGeer, Charles.** Mémoires pour servir à L'Histoire des Insectes. Vol. II, pt. II, Stockholm. Mem. 9, Ephemeris, p. 617-660. Pls. 16, 17, 18.
1755. **DeGeer, Charles.** Observations sur les Ephémères, don't l'accouplement a été vu en partie. Mém. Acad. Paris savants étrang. Vol. II, pp. 461-469, p. 17.
1668. **deMey, Johann.** Commentarius de Johannis Goedaert Metamorphosi Insectorum, cum appendice de Hemerobius. Middleburg, 8.
1883. **Desmarest, E.** Notes on swarms of Polymitarceys virgo at Aubigne, France. Bull. Soc. Ent. Fr. (6) iii, p. cvii.
1890. **Dewitz, H.** Einige Betrachtungen betreffend das geschlossene Tracheensystem der Insekten larven. Zool. Anz. Leipzig XIII.
1891. **Dewitz, H.** Haben die Jugendstadien der Libellen und Ephemeriden ein geschlossenes Tracheensystem oder nicht? Leopoldina XXVI, No. 23-24.
1910. **Drenkelfort, Heinrich.** Neue Beitrage zur Kenntniss der Biologie und Anatomie von Siphurus lacustris Eaton. Zol. Jahrb. Jena Abth. für Anatomie Bd. 29, Hft. 4. pp. 527-617 mit 3 Taf.
1849. **Dufour, Leon.** Comptes rendus de l'Academie des sciences de Paris.
1907. **Durken.** Die Tracheenkiemenmuskulatur der Ephemeriden unter Berücksichtigung der Morphologie des Insekten flugels. Zs. wiss. Zool. Leipzig, Vol. 87, pp. 435-550, 3 pl.
1837. **Dutrochet.** Mémoires pour servir à l'histoire anatomique et physiologique des Vegetaux et Animaux.

1906. **Dziedzielewicz, Josef.** Sur quelques Ephemerides de la Galicie. Kosmos. Lwow, 31, pp. 386-390. (Short notes of Polish Ephemeridae [in Polish] *Polymitarcys virgo*.)
1865. **Eaton, A. E.** Occurrence of Females of Cloeon under stones. Ent. M. Mag. II, p. 14. (Baetis).
1866. **Eaton, A. E.** Ann. & Mag. N. H. 3rd XVIII, pp. 145-146.
1867. **Eaton, A. E.** On Some British Neuroptera. Ann. and Mag. of Nat. Hist. 3rd ser. XIX, pp. 395-401.
1868. **Eaton, A. E.** On some points in the Anatomy of the immature *Caenis macrura*, Stephens, London, Trans. Ent. Sc. pp. 279-282.
1868. **Eaton, A. E.** An outline of a rearrangement of the genera of the Ephemeridae. Ent. Mag. London V, pp. 82-91.
1869. **Eaton, A. E.** On the larvae. Ent. Mag. London V, p. 131. On *Centroptilum*. Ent. Mag. VI, pp. 131-132.
1870. **Eaton, A. E.** Descriptions of new species and notes on others. London Trans. Ent. Soc., p. 1.
1871. **Eaton, A. E.** Monograph on the Ephemeridae, Pl. I, London, Trans. Ent. Soc. pp. 1-161, pls. i-vi.
1873. **Eaton, A. E.** Critical notes on the "Monograph" communicated by H. A. Hagen, chiefly connected with bibliography and synonymy. Transact. Ent. Soc. London, 1873, pp. 381-406.
1876. **Eaton, A. E.** P. E. Soc. p. vii. Deficiency of legs in *Campsurus*.
1879. **Eaton, A. E.** *Caenis kungu* and *cibaria* Spp. nn. Ent. Mag., London, XV, p. 268. Cf. also appendix by Eaton to Elton's Journals, London, 1879.
1880. **Eaton, A. E.** Short additional characters for *Baetisca obesa* Say., London Proc. Ent. Soc.
1880. **Eaton, A. E.** *Caenis dimidiata* reported to be luminous. London Pro. Ent. Soc., p. viii.
1880. **Eaton, A. E.** Method of preserving nymphs in fluid. Canad. Entomol. London, Canada, xii, p. xb.
1881. **Eaton, A. E.** *Caenis maxima*. Ent. Mag., London, XVIII, p. 21.
1881. **Eaton, A. E.** An announcement of new genera of the Ephemeridae. Ent. Mag., London, xvii, p. 191-197, and xviii.
1882. **Eaton, A. E.** An announcement of new genera of Ephemeridae. Ent. Mag., London, xviii, pp. 207-208.
1883. **Eaton, A. E.** A Revisional Monograph of Recent Ephemeridae. Part I, London Transact. Soc. (2) iii, pp. 1-77, pls. I-XXIV.
1885. **Eaton, A. E.** A Revisional Monograph of Recent Ephemeridae. Parts III and IV. London Trans. Linn. Soc. (2) iii, pp. 153-281, pls. XLVI-LXIII.
1887. **Eaton, A. E.** Ephemeridae of Portugal. Ent. Mag. London, Vol. XXIV, pp. 4-6.
1887. **Eaton, A. E.** A Revisional Monograph of Recent Ephemeridae. Part V. London Trans. Linn. Soc. (2) pp. 281-319, pls. 64-65.
1888. **Eaton, A. E.** A concise generical synopsis, with an annotated list of the species of British Ephemeridae. Ent. Mag. London, XXV, pp. 9-12 and 29-33.
1892. **Eaton, A. E.** New species of Ephemeridae from the Tenasserim Valley. London Trans. Ent. Soc. Part II, pp. 185-190.
1891. **Eaton, A. E.** Notes on some native Ephemeridae in the Indian Museum, Calcutta. Jour. Asiatic Soc. of Bengal, Vol. LX, Part 2, No. 4, pp. 406-413. 6 gen. 10 spec.
1892. **Eaton, A. E.** On two new and some other Japanese species of Ephemeridae. Ent. Mag., London, XXVIII, pp. 302-303.
1892. **Eaton, A. E.** Family Ephemeridae. Biologia Centrali-Americana. pp. 1-16. 1 pl.
1896. **Eaton, A. E.** Ephemeridae in brackish water. Ent. Mag., London, p. 144.
1898. **Eaton, A. E.** Ephemeridae taken by McLachlan in the District of the Lac de Joux (Swiss Jura) in 1898. Entom. Mag., London (2) IX, pp. 265-266. (with figure.)
1899. **Eaton, A. E.** List of Ephemeridae Hitherto Observed in Algeria with Localities. Ent. Mag. London (2) Vol. X, pp. 4-5. (*Centroptilum*.)

1899. **Eaton, A. E.** An annotated list of the Ephemeridæ in New Zealand. Trans. Ent. Soc. London Part III, pp. 285-293. pl. X.
- Eaton, A. E.** *Siphurus æstivalis*, n. sp. Norway. Ent. Mag. London, XXXIX, p. 30.
1901. **Eaton, A. E.** *Leptophlebia strandii*. Metretopus. Ent. Mag. London, XXXVII, p. 253-54.
1901. **Eaton, A. E.** Ephemeridæ collected by Herr E. Strand in South and Arctic Norway. Ent. Mag. London (2) Vol. 12, pp. 252-55. (*Leptophlebia*, *Metretopus*).
1902. **Eaton, A. E.** Nachtrag. Pseudoneuropteren von. Therese Pri von Bayern. Berliner Ent. Zs. Bd. XLVII, p. 279. (a defaced *Campsurus* from Colombia.)
1903. **Eaton, A. E.** A new species of Ephemeridæ from Norway. Ent. Mag. London (2) XIV, pp. 30-31. (*Palingenia*).
1857. **Edwards, H. Milne.** Lecons sur la Palingenia et l'anatomie comparee.
1891. **Exner, S.** Die Physiologie der Facettirten Angen von Krebsen und Insecten. Leipzig und Weine. (Shafer cites.)
1774. **Fabricius, J. Christ.** *Ephemera venosa*, Systema Entomologica, p. 303 and 304. Nos. 1-11 ordo.
1850. **Fischer, L. H.** Beitrage zur Insecten. Fauna um Freiburg im Breisgau. 17 Jahrerber. des Mannheim. Ver fur Naturk. Mannheim, pp. 60-70.
1880. **Forbes, S. A.** The Food of the Darters. Amer. Natural. Vol. XIV. pp. 697-703.
1888. **Forbes, S. A.** Studies of the Food of the Fresh-Water Fishes. Bull. Ill. State Lab. Vol. II, Art. VII.
1853. **Forster.** Notz uber die Eintage fliege. Correspond. Bl. Zool. Mineral. Ver Regensburg, 1853. T. 7, p. 91-93.
1888. **Fritze, A.** Ueber den Darmkanal der Ephemeriden Frieburg i. B., Ber. natf. Ges. IV, pp. 5-24, pls. ii and iii.  
Noticed in Jour. R. Micr. Soc. 1889, p. 206.
1874. **Gegenbauer.** Manuel d'anatomie comparee.
1873. **Gentry, Thomas G.** A swarm of May-flies on the Susquehanna River. Philadelphia, Pa., Pro. Acad. Nat. Sci., p. 350.
1765. **Geoffroy.** Histoire naturelle des environs de Paris.
1799. **Geoffroy.** Histoire abregees des Insectes. Paris. 1764, 2 vo. 4 plates.
1700. **Godart.** Metamorphoses naturelles des Insectes. Amsterdam. 3 vol.
1829. **Goring and Pritchard.** Nat. Hist. Obj. for Microscope. (Cloeon.)
1832. **Gray, George.** Griffith Animal Kingdom. 1832. 8. Tome II, p. 321.
1868. **Grenacher, H.** Beitrage zur Kenntniss des Eis der Ephemeriden. Zs. wiss. Zool. Leipzig, XVIII. Bd. I, pp. 95-98, pl. 5.
1903. **Gross, J.** Ueber das Palmensche Organ der Ephemeriden. Zool. Jahrb. Jena, Abt. Morphol. Bd. 19, p. 91-106. 3 Figs. 1 pl. Rev. by K. Escherich. Allgemeine Zeitschrift fur Entomologie. Bd. 9, 1904, pp. 43-4.
1849. **Hagen, Hermann.** Uebersicht der neueren Literatur betreffend die Neuroptera Linne. Stettiner Ent. Ztg. Sti. v. X, p. 355-71.
1855. **Hagen, Hermann.** Die Ephemeriden-Gattung *Eligoneuria*. Ent. Zeitung Stettin XVI, p. 262-270.
1863. **Hagen, H. A.** Synopsis of the British Ephemeridæ. 1863, London, Trans. Ent. Soc.
1864. **Hagen, Hermann.** Neuropteres (non Odonates) de la Corse, recueillis par M. E. Bellier de la Chavignerie en 1860 et 1861. Ephem. 8 species. Ann. Soc. Ent. Fr. 4 e. ser. IV, pp. 38-46.
1864. **Hagen, Hermann.** *Bætis fallax*, sp. n., Hagen. Ann. Soc. Ent. Fr. 4 e. ser. Vol. IV, pp. 38-46.  
*Bætis*, *zebrata*, sp. n. Hagen from Corsica. Ann. Soc. Ent. Fr. 4 e. ser. Vol. IV, pp. 38. Ann. Soc. Ent. Fr. 4 e ser. Vol. IV, pp. 39.
1868. **Hagen, H. A.** On *Lachlania abnormis*, a new genus and species from Cuba, belonging to the Ephemerina. Boston, Mass. Proc. Soc. Nat. Hist. Vol. XI, pp. 372-374.

1873. **Hagen, H.** Report on the Pseudoneuroptera and Neuroptera of North America in the collection of the late Th. W. Harris. Boston, Mass. Proc. Soc. Nat. Hist. Vol. XV, pp. 263-301.
1873. **Hagen, H.** Compiled by Eaton. Notes on the Ephemeridæ. London, Trans. & Proc. Ent. Soc. p. 381-406.
1875. **Hagen, H.** Ephemera decora, gutturalata and natata re-described. Report Geolog. Survey of Territories for 1873, pp. 578-580.
1881. **Hagen, H.** Einwurfe gegen Dr. Palmen's Ansicht von der Entstehung des geschlossenen Tracheensystems. Zool. Anz. Leipzig Jahrg. III.
1888. **Hagen, H.** Unsere gegenwartige Kenntniss der Ephemeriden. Stettiner. Ent. Ztg. Juli Sept. Vol. 49, pp. 221-232.
1890. **Hagen, H.** Notes on Hexagenia albivitta, Ulk. bilineata, Say. Cimbata, Pict. S. E. Z. li, pp. 11-13.
1887. **Halford.** Ephemerella ignita, oviposition and duration in the egg. Ent. Mag. London XXIII, p. 235.
1904. **Handlirsch, A.** Permian Ephem. New forms. Palæo-Entomology, p. 125.
1906. **Handlirsch, A.** Revision of American Paleozoic Insects. (Trans. by Lucy P. Bush) Washington, D. C. Smithsonian Inst., U. S. Nat. Mus. Proc. 29, No. 1441, pp. 661-820.
1906. **Handlirsch, A.** Die fossilen Insecten und die Phylogenie der rezenten Formen. Ein Handbuch für Palaontologen und Zoologen. Leipzig.
1853. **Herklots, Janus A.** Het Haft. de langstaarte Eendagsvlieg. Jaarb. K. Zool. Genootsch. Amsterd. pp. 117-123.
1896. **Heymons, R.** Grundzuge der Entwicklung und der Körperbaues von Odonaten und Ephemeriden. Abhandl. der kgl. preuss. Akademie d. Urssensch. zu Berlin. 1896.
1896. **Heymons, R.** Ueber die Lebensweise und Entwicklung von Ephemera vulgata L.
1896. **Heymons, R.** Zur Morphologie der Abdominalanlage bei Insekten. Morhh. Jahrb. Leipzig, vol. XXIV, 1 Taf.
1896. **Heymons, R.** Ueber die abdominal Körperhänge der Insekten. Biol. Centralbl. Leipzig, Vol. XVI.
1897. **Heymons, R.** Ueber den Nachweis der Viviparität bei den Eintagsfliegen. Zool. Anz., Leipzig, pp. 205-206.
1897. **Heymons, R.** Ueber den Nachweis der Viviparität bei den Eintagsfliegen. Abstr. J. R. microsc. Soc. London Pt. 4, p. 279.
1899. **Heymons, R.** Der Morphologische Bau der Insektenabdomens. Zool. Centralbl. Leipzig, Jahrg. VI.
1908. **Hoffman, Kurt Otto.** Hochzeitsflug und Todestanz der Eintagsfliegen. (Kosmos. Handweiser für Naturfreunde hrsg. v. Kosmos. Stuttgart [monatlich]). Bd. 5, pp. 242-244. 1 Fig.
1902. **Hubner, O.** Neue Versuche aus dem Gebiet der Regeneration und ihre Beziehungen zu Anpassungserscheinungen. Zool. Jahrb. Jena Abth. für Syst. XV, pp. 461-498, pls. 28-29.  
Summary, Zool. Centralbl. Leipzig, 1902, pp. 427-428 by Bergh.
1881. **Hunter, E. A.** Letter concerning Flight of Ephemeræ, with an answer by J. A. Lintner. The Cultivator and Country Gentleman, Vol. 46, p. 7.
1852. **Imhoff, Ludwig.** Oligoneuria Rhenana. Bericht über Verhandl. d. naturf. Gesellsch. in Basel. T. 10, pp. 177-180.
1885. **Johnson, W. F.** Great swarms of Ephemeridæ on Lough Neagh, Ireland. Ent. Mag. London, XXII, p. 165.
1871. **Joly, N.** Sur l'hypermétamorphose de la Palingenia virgo à l'état de larvæ; analogies de cette larve avec les Crustacés. Mem. Soc. Toulouse (7) iii. pp. 379-386, Ann. Sci. Nat. Paris (5) XV, art. 10, pp. 1-5.
1872. **Joly, N.** Sur un cas nouveau d'hypermétamorphose constatée chez la Palingenia (Polymitarceys) Ann. Sci. Nat. Paris, 5 ser. Zool. T. XV.
1872. **Joly, N. and E.** Études sur le prétendu Crustacé au sujet duquel Latreille a créé le genre Prosopistoma, et qui n'est autre qu'un véritable insecte hexapode. Ann. Sci. Nat., Paris (5) XVI, No. 7, pp. 1-16, pl. 3.
1874. **Joly, E.** Note sur les caractères d'une larve d'insectes Orthoptères de la famille des Éphéméridines. Rev. Soc. sav. (2) iii.

1875. **Joly, N. and E.** Nouvelles recherches tendant à établir que le prétendu Crustacé décrit par Latrielle sous le nom *Prosopistoma* est un véritable insecte de la tribu des Éphémérides. *Rev. Sci. Nat. Paris* ii, (separate pp. 1-15.)
1876. **Joly, N. and E.** Contributions à l'histoire naturelle et à l'anatomie des Éphémérides. *Rev. Sci. Nat. Paris* V. (dec., 1876; separate, pp. 1-26, with 4 pls.)
1876. **Joly, N.** Études sur l'embrogénie des Éphémères, notamment chez la *Palingenia virgo*. *Mem. Ac. Toulouse* (separate, pp. 1-12, pls.) cf. *Comp. Rend. lxxxii*, pp. 1030-1034, and *Ann. Mag. Nat. Hist. London*, (4) xvii, pp. 481-484.
1876. **Joly, E. and N.** Les Éphémères, leur organization, leurs métamorphoses, leurs mœurs, et leur industrie. *La Nature*, V, pp. 10-15, 43-47.
1876. **Joly, E.** Études sur l'appareil reproducteur des Éphémérides. *C. R. lxxxiii*, pp. 809-813.
1876. **Joly, E.** Sur une nouvelle espèce du genre d'Éphémérides *Oligoneuria* (*O. rhenana*) par feu le Dr. L. Imhoff; traduit de l'Allemand et annoté. *Bull. Soc. Angers*, 4 me et 5 me années, pp. 37-46.
1877. **Joly.** On the reproductive apparatus of the Epheméridæ. *Ann. and Mag. Nat. Hist., London*, XIX.
1878. **Joly, E.** Nouvelles observations sur le genre *Prosopistoma*. *Pet. Nouv.* ii, p. 265.
1879. **Joly, E.** *Prosopistoma punctifrons*. *Fenill. Nat.* VIII, pp. 99-100. *Fenill Nat.* IX, pp. 24-25. *Bull. Soc. Nimes*, VII, 1879, C. R. LXXXVII, pp. 263-265.
1880. **Joly, E.** Sur la nymphe du genre d'Éphémérides *Bætisca*, par Benj. D. Walsh M. A., traduit de l'anglais et annoté. *Bull. Soc. Angers*, viii and ix, pp. 157-173, with plate.
1904. **Jordan, D. S. and Evermann, B. W.** *American Food and Game Fishes.* (p. 135. The Cisco of Lake Tippecanoe). New York.
1824. **Keating, William H.** Narrative of an Expedition to the Source of the St. Peters River. (Notes by T. Say). Vols. I, II. Philadelphia.
1895. **Kellogg, V. L.** The Epheméridæ and venation nomenclature. *Psyche*, Boston, Mass. VII, pp. 311-315.
1885. **Kirby, W. F.** *Elementary Textbook of Entomology*, London.
1904. **Klapalek, F.** Über die Gonopoden der Insekten und die Bedeutung derselben für die Systematik. *Zool. Anz. Leipzig*, Bd. XXVII, No. 14.
1905. **Klapalek, F.** Plecopteren und Ephemériden aus Java. *Mitteil aus dem Natur. hist. Mus. XXII*, Hamburg.
1905. **Klapalek, F.** Epheméridarum species quatuor novæ. (Bohmisch) *Prag. Cas Ceske Spol. Entomol.* 2, pp. 75-79.
1907. **Klapalek, F.** Beitrag zur Kenntniss der Trichopteren und Ephemériden fauna in den Ostharpthen. *Prag. Cas. Ceske Apol. Entomolog.*, 4, pp. 24-36.
1906. **Klapalek, F.** Contributions to a knowledge of the Neuroptera of Croatia, Slavonia, etc. *Prag. Rozpr. Ceske, Ak. Brant. Jos.*, Vol. 15, No. 16, 1-8.
1848. **Koelliker.** Ueber die Gattung *Gregarina*. (*Gregarines in alimentary canal of Ephem. vulgata* n.) *Zeitschr. für wissenschaft. Zoologie von Siebold.* Tom. I, p. 33.
1723. **Kulmers, Johann Adam.** Von einem gewissen Fisch. *Insect. Bresl. Natur. w. Kunstgesch.* pp. 292-293.
1909. **LaBaume, Wolf.** Über die Metamorphose der Ephemériden. *Sitz.-Ber. Ger. nat. Freunde Berlin*, pp. 137-153.
1838. **Lacordaire, J. T.** Introduction à l'Entomologie ii, 77. (Circulation described.)
1900. **Lameere, A.** *Manual de la faune de Belgique.* T. II. *Insectes inférieurs.* Bruxelles, 858 pp.
1802. **Latreille, P. A.** *Histoire naturelle des Crustacés et des Insectes.* Paris, 1802, Tom. 1-14.
1817. **Latreille.** *Nouveau Dictionnaire d'histoire naturelle appliquée aux arts.* (cites *Vayssière*, p. 8.)

1829. **Latreille.** (In insect part of 10th ed.) Regne Animal, Cuivier.
1833. **Latreille.** Nouvelles Ann. du Museum. (t. II).
1898. **Letacq, A. L.** Sur une pluie d'Ephemeres vierges qui a eu lieu a Remalard (Orne) le 7 Aout. Bull. Soc. Amis. Sc. nat. Rouen vol. XXXIII (4) Ann. pp. 88-89.
1855. **Leuckart, R.** Uber die Mikropyle und die feineren Bau der Schalenhaut bei den Insecteneier. Archiv. f. Anst. & Phys. Berlin. (Muller's Archiv. 1858, ref. given by Grenacher.)
1882. **Lewis.** Contributed by A. E. Eaton. Proceed. Ent. Soc. Lond. p. xiii. Teloanodes, luminous. (type Cloe tristes).
1899. **Lillie, C. O.** On New Zealand Ephemeridæ; Two species. Trans. Proc. N. Zealand Inst. XXXI, p. 164-169, 6 pls.
1901. **Lillie, C. D.** Notes on New Zealand Ephemeridæ. Tr. N. Zealand Inst. xxxiii, pp. 149, 150, p. VII.
1735. **Linne.** Syst. Nat. ed. xii, Pallass MS.
1889. **Lintner.** Fourth Rep. on injurious and other insects of the State of New York, pp 121-124. (Remarkable occurrences of Ephemeridæ. Economic value for fish food.) xli pp. 6-234.
1861. **Loew, Franz.** Beitrage zur Keuntniss der Orthoptera. Verhandl. Wien. Zool. Bot. Gesellsch. T. II, pp. 405-10.
1866. **Lubbock, John.** On the Development of Chloeon dimidiatum. Trans. Linn. Soc. XXIV & XXV. Part I. Stages 1-17 in vol. 24, pp. 61-78. Pls. 17, 18. Part II. Stage 18-20 in Vol. 25, pp. 477-492. Pls. 58, 59.
1871. **Lucas.** Specimens of newspaper Entomology. Preceitate burials from May-flies. Ann. Soc. Ent. Fr. (5) i Bull. p. xliiii.
1882. **Lucas, H.** Bull. Soc. Ent. Fr. (6) ii, p. xxxii, p. xcvi. (Prosopistoma punctifrons).
1902. **Marchal, C.** Une remarquable e'cllosion d'Ephemeres. Bull. Soc. Hist. Nat. Autun. T. 15, Proc. verb. pp. 260-262.
1869. **McLachlan.** Palingenia hecuba, Hagen. (from Veragua). London Trans. Ent. Soc. p. viii.
1873. **McLachlan.** On Oniscigaster wakefieldi which differs from all known genera by the terminal abdominal segments being dilated into wing-like lobes. Ent. Mag. London X, p. 109. O Wakefieldi, l. c. p. 110 (with fig.)
1877. **McLachlan, R.** Note sur l'insecte fossile decrite par M. P. de Borre sous le nom de Breyeria borinensis. C. R. Ent. Belg. XX, pp. xxxvi & xxxvii.
1880. **McLachlan.** Notes on an immense swarm of Oligoneuria rhenana observed at Basle. Ent. Mag. London, xvii, p. 164.
1881. **McLachlan.** A list of 18 species determined by Eaton, collected in Belgium. C. R. Ent. Belg. XXV, p. cxxxv.
1894. **McLachlan.** E. pictiventris. W. China. Ann. Nat. Hist. (6) XIII; p. 428. E. hudsoni, New Zealand, Ent. Mo. Mag. p. 270.
1896. **Meinert, F.** Neuroptera, Pseudoneuroptera, etc. Groenlandica. Vid. medd. pp. 154-177.
1905. **Metchikoff, Elie.** Nature of Man. Studies in Optimistic Philosophy. Trans. P. C. Mitchell Putnam, p. 271-276.
1864. **Meyer-Durr.** Baetis picteti. Schw. Ent. Geo. p. 221.
1864. **Meyer-Durr, H.** Zusammenstellung der auf meiner Reise durch Tessin und Ober-Engadin (1863) beobachteten und eingesammelten Neuroptern Mittheil. Schweiz. Entom. Ges. May, 1864, pp. 219-225.
1895. **Miall, L. C.** The Natural History of Aquatic Insects. Illus. by A. R. Hammond, London, 395, pp.
1900. **Mocsary, Sandor.** Magyarorszag Neuroptera- Ungarns Neuropteren. Yermeszetr. Fuzetek XXIII, pp. 109-116.
1904. **Moore, R. M.** Courtship of May-flies. Baetis propinquus, relations of the sexes. Ent. News, Philadelphia, P., Vol. XV, p. 289-290.
1634. **Moufet.** Insectorium sine minimorum animalium theatrum. Londres. 1634 folio, p. 63.
1776. **Muller, A.** Zoologica Danica prodromus.

1865. **Muller, A.** States that eggs of *Oligoneuria rhenana* are attached to the last segment of the abdomen by a gelatinous substance. *Ent. Mag.* London, Vol. 1, p. 262.
1894. **Nagel.** Want of sense organs in antennæ of *Ephemera*. *Bibliotheca. Zool.*, Leipzig, XVIII, p. 118.
1904. **Navas.** *Ephemera hispanica*. *Bol. Soc. Aragon.* ii n. sp.
1905. **Navas, Longinos.** *Notes zoologicas VII*, *Bol. Soc. Aragon*, IV, pp. 49-55, pl. ii.
1901. **Needham, J. G. and C. Betten.** *Aquatic Insects in the Adirondacks.* New York State Mus., Bull. 47. Sept., 1901.
1903. **Needham, J. G.** Food of Brook Trout in Bone Pond in *Aquatic Insects of New York State.* Bull. 68, N. Y. State Mus. pp.
1905. **Needham, J. G.** (*Ephemeridæ* in) *May-flies and Midges of New York.* Bull. 86, N. Y. State Mus.
1908. **Needham, J. G.** Report of the Entomologic Field Station at Old Forge, N. Y. Bull. 124, N. Y. State Museum.
1908. **Needham, J. G.** A peculiar May-fly from Sacondaga Park. Report State Ent. New York. Appendix. A. pp. 71-75. (*Siphonisca/acrodromia* Needham).
1909. **Needham, J. G.** Notes on the Neuroptera in the Collection of the Indian Museum. *Records of the Indian Museum*, Vol. III, Pl. III, No. 12. (*Ephemeridæ* pp. 191-192).
1836. **Newman, Edward.** A few words upon the Transformations of Insects. III, pp. 12-20. (p. 18, discussion of sub-imago stage).
1885. **Newman, E.** *The Grammar of Entomology*, pp. 248-255.
1791. **Olivier.** *L'Histoire naturelle des Insectes.*
1908. **Oppenheim, S.** Segmentregeneration bei *Ephemeriden* Larven. *Zool.* Leipzig, Vol. XXX, pp. 72-77.
1869. **Packard.** Guide to the study of Insects, pp. 595-596.
1899. **Packard.** Duration of life of *Leptophlebia cupida*. *Psyche*, Boston, Mass., V. p. 168.
1877. **Palmen, J. A.** Zur morphologie des Tracheensystems. Leipzig, Engelmann.
1883. **Palmen, J. A.** Zur vergleichenden Anatomie der Ausführungsgnage der Sexualorgane bei den Insekten. (Prelim. paper) *Morph. Jahrb*, Vol. IX, pp. 1-8.
1884. **Palmen, J. A.** Über paarige Ausführungsgnage der Geschlectorgane bei Insekten; eine morphologische Untersuchung. *Helsingfors*, pp. 1-107, 5 pls. *Abstract Ann. Nat.* XVIII, pp. 1152-1153.
1884. **Palmen, J. A.** Zur Morphologie des Tracheensystems. *Helsingfors*.
1908. **Peterson, Esben.** Beitrage zu einem Verzeichnisse der Neuropteren fauna des arktischen Norwegens. *Aarshefter fra Troms Museum.* Troms. Vol. 25, pp. 149-151.
1910. **Peterson, Esben.** *Danmarks Fauna.* G. E. C. Gad. Kobenhavn.
1895. **Peytoureau, S. A.** Contribution à l'étude de la morphologie de l'armure génitale des insectes. Thèses présentées à la faculté des sciences de Paris. Serie A, No. 223, (ordre 837. Bordeaux, 1895, 248, pp., XXII pls.)
1843. **Pictet, Francois, J.** *Histoire naturelle générale et particuliere des Insectes Neuroptères.* Genève, Ressman.
1865. **Pictet.** *Synopsis Nevv. d'Espagne.* 68 species of Pseudo-Neuroptera inhabiting the Spanish Penin. *Pub. Geneva.*
1905. **Popovici-Bazosanu, A.** Beitrage zur Kenntniss des Circulations systems der Insekten. *Jenaische Zs. Natw.* Vol. 40, pp. 667-696.
1906. **Popovici-Bazosanu, A.** Contributions à l'étude de l'organisation des larves des Ephémérides. *Arch. Zool, Paris*, ser. 4, 5, 1906. *Notes et revue* (lxvi-lxxviii).
1906. **Popovici-Bazosanu, A.** Sur L'existence des vaissaux sanguins caudaux, chez les Ephémérides adultes. *Comptes. Rend. des Sciences et Memoires de la Societe de Biologie*, Vol. 58.
1742. **De Reaumur.** *Mémoires pour servir à L'Histoire des Insectes.* Tome 6, p. 457-522. 5 pls.



1886. **Redtenbacher, J.** Vergleichende Studien über das Flügelgeäder der Insecten. Ann. K. K. Nat. Mus. 1, pp. 153-232, pls. IX and XX, pp. 165-166, pl. IX.
1881. **Riley, C. V.** Note on exuviation in flight. McLachlan's observations on *Oligoneuria*, Riley's on *Polymitaereys alba*. Amer. Nat., New York, XV, p. 395.
1877. **Ronald, A.** Fly Fisher's Entomology, 8th ed. London.
1878. **Rostock, M.** Die Ephemeriden und Psociden Sachsens. J. B. Ver. Zwickau, pp. 76-100.
1888. **Rostock, M.** Neuroptera Germanica. Die Netzflugler Deutschlands, mit Berücksichtigung auch einiger ausser-deutschen Arten nach der analytischen Methode unter Mitwirkung von H. Kolbe bearbeitet. Jahrb. d. Ver. f. Naturk. z. Zwickau, 1887, pp. 140-155, taf. viii. fig. 44-48 (1888).
1859. **Say, Thomas.** American Entomology; a description of the insects of North America. Boston, n. d. 2 v. 8. (pp. 170-173 description sys. only.) pp. 411.
1890. **Schiller.** Die Ephemeriden-larven Sachsens. Sitz in abh der naturwiss in Dresden, pp. 44-49 with 2 pls. In Abhandl. d. Naturf. Gesellschaft Isis Dresden, vol. XVI.
1887. **Schoch, G.** Ephemerella ignita, Poda, eine paedogentische Eintagsfliege. M. T. schw. Ent. Ges. VII, pp. 48-50.
1876. **Schrank, Franz von Paula.** Verzeichniss einiger Insecten deren im Linneischen Systeme nicht gedacht ist. Schrank Seitrage, p. 59-98.
1867. **Scudder, S. H.** An inquiry into the zoological relations of the first discovered traces of Fossil Neuropterous Insects in North America. Anniv. Mem. Bost. Soc. Nat. Hist. Vol. 1, pp. 173-192, plate 6.
1880. **Scudder, S. H.** Hexagenites (g. n.) veyenberghi (sp. n.) Scudder. Anniv. Mem. Bost. Soc. Nat. Hist. p. 6, fossil in the Jurassic of Solenhofen.
1880. **Scudder, S. H.** The Devonian Insects of New Brunswick. Anniv. Mem. Bost. Soc. Nat. Hist., pp. 1-41, pl. 1.
1890. **Scudder, S. H.** The Fossil Insects of N. Am., with notes on some European species. Vol. 1, Pretertiary. Vol. II. The Tertiary. New York.
1794. **Seetzen, Ulrich J.** Beitrag zur Naturgeschichte der Ephemera lutea. Meyer's Magaz. f. d. Thiergeschichte. Vol. 1, p. 41-63.
1906. **Seiler, W.** Beiträge zur Kenntniss der Ocellen der Ephemeriden. Zool. Jahrb. Anat. Vol. XXII, pp. 1-40, pls. 1, 2. Abst. by Hesse. Zool. Centralbl. 1906, p. 179.
1907. **Sellards, E. H.** Types of Permian Insects. Amer. J. Sci., New Haven, Conn., Ser. 4. Vol. 23, pp. 345-55.
1888. **Selys-Longchamps.** Catalogue raisonné des Orthoptères et des Neuroptères de Belgique. Ann. Ent. Belg. Vol. XXXII, pp. 103-203.
1907. **Shafer, D. S.** Structure of the divided Eyes. Washington Ac. VIII, pp. 459-486.
1895. **Sharp, D.** The Cambridge Natural History, ed. by S. F. Harmer and A. E. Shipley. Vol. V. Insects pt. 1, pp. 81-584. London.
1904. **Shipley, A. E.** The Orders of Insects. Zool. Anz. Leipzig, Vol. XXVII, pp. 259-262.
1837. **von Siebold, C. T. E.** Ueber die viviparen misciden. Fropiep Notz. 1837, T. 3, pp. 336-340. (Noted by Haymons, '97).
1904. **Slade.** Ephemeridæ re-entering water. Ent. Mag. London, XL., p. 15.
1871. **Smith, S. J.** Notice of Fossil Insect's Wing. Sci., p. 44.
- Smith.** Swarms of a May-fly. Ent. News., London, Vol. XV, p. 318. Philad.
1871. **Staverly, E. F.** British Insects. London.
1907. **Steinmann.** Ephemerid larvæ described and figured. Ann. Biol. lacustre. Bruxelles, 2, pp. 73-82.
1907. **Sternfeld, Richard.** Die Verkummerung der Mundteile und der Funktion-swechsel des Darms bei den Ephemeriden. Zool. Jahrb., Jena, Abt. fur Anatomie & Ontogenie, Vol. 24, p. 415-430.
1842. **Straus, Durckheim.** Traite d'anatomie comparee.

1758. **Swammerdam, John.** The Book of Nature or the History of Insects.
1741. **Targioni-Tozzetti.** Lettera sopra una numerosis sima specie die farfalle vedutasi in Firenze sulla meta di Luglio. Firenze, Vol. 4, pp. 32, pl. 1.
1906. **Thoreau, Henry D.** The Writings of Thoreau edited by Bradford Torrey, Vol. XII. p. 157, p. 324, p. 331. Vol. XIV, p. 370. Vol. XV, p. 404. Cambridge.
1840. **Triepke.** Einige Bemerkungen uber Ephemera flos aguse Illgr. Stettiner Ent. Ztg., T. I., pp. 54-58.
1907. **Tucker, Elbert S.** Some Results of Desultory Collecting of Insects in Kansas and Colorado. Kansas Univ. Science Bull., Vol. IV., No. 2. (List of Ephemeroidea pp. 76-77).
1866. **Tuffen West.** Description of skin cast by Baetis in its last molt. London Trans. Micr. Soc. XIV, pp. 69-70, pl. 7, figs. 8-11.
1901. **Tumpel, R.** Die Geradflügler Mitteleuropas. Wilchens. Eisenach.
1908. **Ulmer, Georg.** Trichoptera and Ephemeroidea. Die Fauna Sudwest-Australiens, hrsg. V. W. Michaelson and R. Hartmeyer. Bd. 2, Lfg. 3, Jena.
1909. **Ulmer, Georg.** Ephemeroidea von Madagaskar und den Comoren. Hamburg. 7, Text. fig. Sonderdruck aus Voezkon Reise in Ostrafrika in den Jahren 1903-1905. Band II. Stuttgart, 1909.
1878. **Vayssiere, A.** Sur le Prosopistoma variegatum. Monographie zoologique et anatomique. Ann. des Sci. naturelles. 6 ser. Zool. Tom. 9, Plauches 2-5.
1880. **Vayssiere, A.** Metamorphose du Prosopistoma. Ann. des Sci. naturelles. 6 ser. Zool. Tom. II.
1881. **Vayssiere, A.** Etude sur l'etat parfait du Prosopistoma punctiferos. Ann. Sci. Nat. (6) Tom. II, No. 1, pp. 1-15, pl. i.
1882. **Vayssiere, Albert.** Recherches sur l'organisation des Larves des Ephemeroidea. Ann. Sci. Nat. (6) xiii, pt. 1, pp. 1-137, pls. i-x.
1890. **Vayssiere, A.** Monographie Zoologique et Anatomique du genre Prosopistoma, Latr. Ann. Sci. Nat. (7) ix, pp. 19-87. pls. II-V.
1893. **Vayssiere, A.** Prosopistoma deguernei, Sennegal. Ann. Sci. Nat. XV, p. 338.
1895. **Vayssiere, A.** Description zoologique de l' Enthyphlocia sikorai, nouvelle espece d'Ephemeroide de Madagascar. Ann. Soc. Ent. France, Vol. LXIII, 1894, pp. 296-306, pl. V.
1906. **Venour, S.** Ephemera danica. Mull., coupling with subimago. Entomologist's Monthly Mag., Vol. 42, p. 258.
1897. **Verhoeff, C.** Bemerkungen uber abdominal Korperanhänge bei Insekten und Myriapoden. Zool. Anz. Jahrg. XX.
1905. **Voss, Fr.** Über den Thorax von Gryllus domesticus mit besonderer Berücksichtigung der Flugelkenne und dessen Bewegung. Zeitschr. für wiss. Zool. Bd. LXXVIII, 3 taf. p. 703.
1908. **Wagner, George.** Notes on the Fish Fauna of Lake Pepin. Transact. Wisconsin Acad. of Sciences, Arts and Letters, Vol. XVI., pt. 1.
1853. **Walker, Francis.** Catalogue of the specimens of Neuropterous Insects in the collection of the British Museum, London, by order of Trustees. 8. p. 477-585.
1882. **Wallengren, H. D. J.** Forteckning pa de Ephemeroidea som hittels blifvit funna pa Skandinaviska halfou. Ent. Tiskr., Vol. III, pp. 173-178; 204 and 205.
1863. **Walsh, B. D.** Observations on certain N. A. Neuroptera, by H. Hagen, M. D., of Koenigsburg, Prussia; translated from the original French MS., and published by permission of the author, with notes and descriptions of about twenty new N. A. species of Pseudoneuroptera. Proc. Ent. Soc. Philadel., Vol. II, pp. 167-272.
1864. **Walsh, B. D.** On the Pupa of the Ephemeroidea genus Baetisca. Walsh. Philadelphia, P., Proceed. Ent. Soc., Vol. III, pp. 200-206.
1653. **Walton, Izaak.** The Compleat Angler or the Contemplative Man's Recreation, p. 91, p. 93, p. 97, p. 115. London.

1882. **Waterhouse, Lewis & Eaton.** Luminosity in *Teloganodes tristis*. Hag. P. E. Soc. p. XIII.
1882. **Wessely, T.** Die Eintagsfliege. Bl. böhmisch Vogel-schutz Ver. Prag. Vol. 2, pp. 55-57. Cf. also Orn. Centralbl, pp. 54-56.
1840. **Westwood.** An Introduction to the Modern Classification of Insects. London, Vol. 3, Vol. II, p. 24.
1872. **Westwood.** Remarks on types of *Prosopistoma* in Madagascar. London Proc. Ent. Soc. p. VI. McLachlan, Ann. Ent. Belg. XV, p. 50, pl. 1, Fig. 1.
1877. **Westwood, J. O.** Notes on the genus *Prosopistoma* of Latrielle. Tr. E. Soc. pp. 189-194, pls. IV and V.
1883. **Weyenbergh, H.** Bydrage tot de Kennis der Zuid-Amerikansche Ephemeren. Tijdschr. Ent. Vol. XXVI, pp. 159-174, pl. X.
1802. **Williamson, Dr. Hugh.** On the Ephemeron *Leukon*, usually called the White Fly of Passaik River. Philadelphia Trans. Amer. Phila. Soc. Vol. 5, p. 71-73.
1842. **Wilson, James.** A Voyage around the Coasts of Scotland and the Isles. 2 Vols. Edinburgh.
1911. **Wodsdalek, J. E.** Phototactic Reactions and their Reversal in the May-fly nymphs *Heptagenia interpunctata*. Say. Biol. Bull. of Marine Biol. Lab. Woods Hole. Vol. XXI, Oct. 1911, pp. 265-271.
1912. **Wodsdalek, J. E.** Natural History and General Behavior of the Ephemera Nymphs *Heptagenia interpunctata* Say. Annals of Ent. Soc. of Amer., Vol. V, No. 1.
1912. **Wodsdalek, J. E.** Formation of Associations in the May-fly nymphs *H. interpunctata*. Journal of Am. Behavior, Vol. II, No. 1.
1912. **Wodsdalek, J. E.** Palmen's Organ and its Function in Nymphs of the Ephemera Nymphs *H. interpunctata* and *Ecdyurus maculipennis*. Biol. Bull. Vol. XXII, No. 4.
1881. **Young, C. F.** Larva of *Ephemera vulgata*. Sci. Goss. XVII.
1904. **Zaitschek, A.** Versuche über die Verdaulichkeit des Chitins und den Nahrungswert der Insecten. Arch. geo. Physiol. Bd. 104, pp. 612-623.
1905. **Zacrel, Jan.** *Palingenia longicauda*. Prag. Cas. Ceske Spol. Entomolog., Vol. 2, pp. 97-99.
1880. **Zimmerman, O.** Über eine eigenthümliche Bildung des Buckengefäßes bei einigen Ephemerenlarven. Zeitschrift für wissenschaftliche Zoologie. Leipzig, pp. 401-406.
1897. **Zimmer, Carl.** Die Facettenaugen der Ephemeren. Zs. wiss. Zool. Leipzig, Bd. 63, Hft. 2, p. 236-262. Ausz. von. R. Heymons, Zool. Centralbl. Jahrg. 5, No. 3, pp. 87-89.

## EXPLANATION OF PLATES.

## PLATE LXII.

- Fig. 1. Mature nymph of *Blasturus cupidus*.  
 Fig. 2. Male imago of *Blasturus cupidus* just after transforming. The cast sub-imago skin shows the dark wing-pads.  
 Fig. 3. *Ameletus ludens*.  
 Fig. 4. Nymph of *Epeorus humeralis*. The hind wing-pads may be seen through the transparent front ones.

## PLATE XLIII.

- Fig. 5. Nymphs of *Callibaetis fluctuans*, climbing about in their natural habitat.  
 Fig. 6. Male sub-imago of *Callibaetis fluctuans* just emerged.

## PLATE XLIV.

- Fig. 7. Half grown nymph of *Potamanthus bettini*.  
 Fig. 8. Mature nymph of *Ephemera*.  
 Fig. 9. Male imago of *Hexagenia bilineata* showing a posture of the fore legs characteristic of the males of many May-flies.

## PLATE XLV.

- Fig. 10. Right gills of *Heptagenia interpunctata*. The first gill is turned with the lower side up and the fimbriate division is fully exposed; in the others it is indicated through the transparent lamella.  
 Fig. 11. Right gills of *Epeorus humeralis*, upper surfaces. When in the natural position the spinose border is in contact with the surface upon which the nymph rests.

## PLATE XLVI.

- Fig. 12. Right gills of *Ironfragilis*, upper surface, gills turned backward in natural position.  
 Fig. 13. Right gills of *Chironetes albomanicatus*, under surface, gills turned forward.

## PLATE XLVII.

- Fig. 14. Mouth-parts of *Callibaetis fluctuans*. a, right, and d, left mandible; b, labrum; c, hypopharynx; e, right maxilla; f, labium.  
 Fig. 15. Maxilla of *Tricorythus allectus*.  
 Figs. 16 and 19. Right and left mandibles of *Ephemerella lata*.  
 Fig. 17. Left maxilla of *Ephemerella serrata*.  
 Fig. 18. Left maxilla of *Ephemerella deficiens*.

## PLATE XLVIII.

- Figs. 20 and 21. Right and left mandibles of *Tricorythus allectus*.  
 Fig. 22. Labium.  
 Figs. 23 and 24. Right and left mandibles of *Potamanthus bettini*.

## PLATE XLIX.

(Structures of nymph of *Hexagenia*).

- Fig. 25. Maxilla.  
 Fig. 26. Second right gill.  
 Fig. 27. First right gill.  
 Fig. 28. Labrum (La) and Clypeus (Cl), outer aspect.  
 Fig. 29. Labrum (La) and Clypeus (Cl), inner aspect, showing the epipharynx lying partly upon the clypeus and partly upon the labrum.  
 Fig. 30. Antenna.  
 Fig. 31. Right mandible, outer aspect.  
 Fig. 32. Right mandible, inner aspect.  
 Fig. 33. Hypopharynx, under side, showing lingua and superlinguæ.  
 Fig. 34. Grinding surface of left molar.  
 Fig. 35. Grinding surface of right molar.  
 Fig. 36. Left mandible, inner aspect.  
 Fig. 37. Left mandible, outer aspect.  
 Fig. 38. Labium outer aspect.

## PLATE L.

- Fig. 39. Right legs of *Ephemerella lata*.  
 Fig. 40. Right fore leg of *Ephemerella serrata*.  
 Fig. 41. Right fore leg of *Ephemerella rotunda*.  
 Fig. 42. Right leg of *Ephemerella deficiens*.  
 Fig. 43. Right fore leg of *Ephemerella tuberculata*.  
 Fig. 44. Right fore leg of *Ephemerella cornuta*.

## PLATE LI.

(Genitalia of imagos of *Siphurus alternatus*.)

- Fig. 45. Rear abdomen of male, F, forceps, ventral view.  
 Fig. 46. Right forceps, showing roughened inner surfaces.  
 Fig. 47. Rear Abdomen, dorsal view, showing c. s., caudal setae; pp, penes and 10s. 10th sternite.  
 Fig. 48. Rear of abdomen, side view.  
 Fig. 49. Dorsal view of penes resting upon the 10th sternite. The white surface, c. e., represents the cut surface of the body wall. The large bases of the penes, a, lying inside the body have been exposed by cutting away the dorsal part of the abdomen.  
 Fig. 50. Part of the abdomen of the female. e. v., egg-valve, with the opening of the vestibule directly beneath.  
 Fig. 51. Inner view of the 7th and 8th sternites with the oviducts, o. v., and the seminal receptacle turned backward to show the ventral side of the receptacle.  
 Fig. 52. Penes removed from the 10th sternite and viewed from the ventral side. o. s. d., opening of seminal duct.  
 Fig. 53. Egg valve, common vestibule and outline of receptacle and oviducts, from without.  
 Fig. 54. Rear abdomen of female, dorsal view.  
 Fig. 55. Dorsal view of dissection of oviducts and vestibule. The top of the vestibule has been cut away and pulled off with the 7th sternite, so as to expose the inner surface of the common vestibule, c. v., and seminal receptacle, s. r.  
 Fig. 56. Rear abdomen, female, ventral view.  
 Fig. 57. Rear abdomen of female, side view, e. v., egg valve.

## PLATE LII.

- Fig. 58. Egg of *Leptophlebia*.  
 Fig. 59. Egg of *Ameletus ludens*.  
 Fig. 60. Egg of *Tricorythus allectus*.  
 Fig. 61. Egg of *Chironetes albomanicatus*.

## PLATE LIII.

- Fig. 62. Egg of *Ecdyurus maculipennis*.  
 Fig. 63. Egg of *Choroterpes basalis*.  
 Fig. 64. Egg of *Heptagenia pulchella*.  
 Fig. 65. Egg of *Heptagenia interpunctata*. Needham.

## PLATE LIV.

- Fig. 66. Egg of *Ephemerella rotunda*.  
 Fig. 67. Egg of *Ephemerella excrucians*.  
 Fig. 68. Egg of *Blasturus cupidus*.  
 Fig. 69. Egg of *Polymitarcys albus*.  
 Fig. 70. Egg of *Siphurus alternatus*.

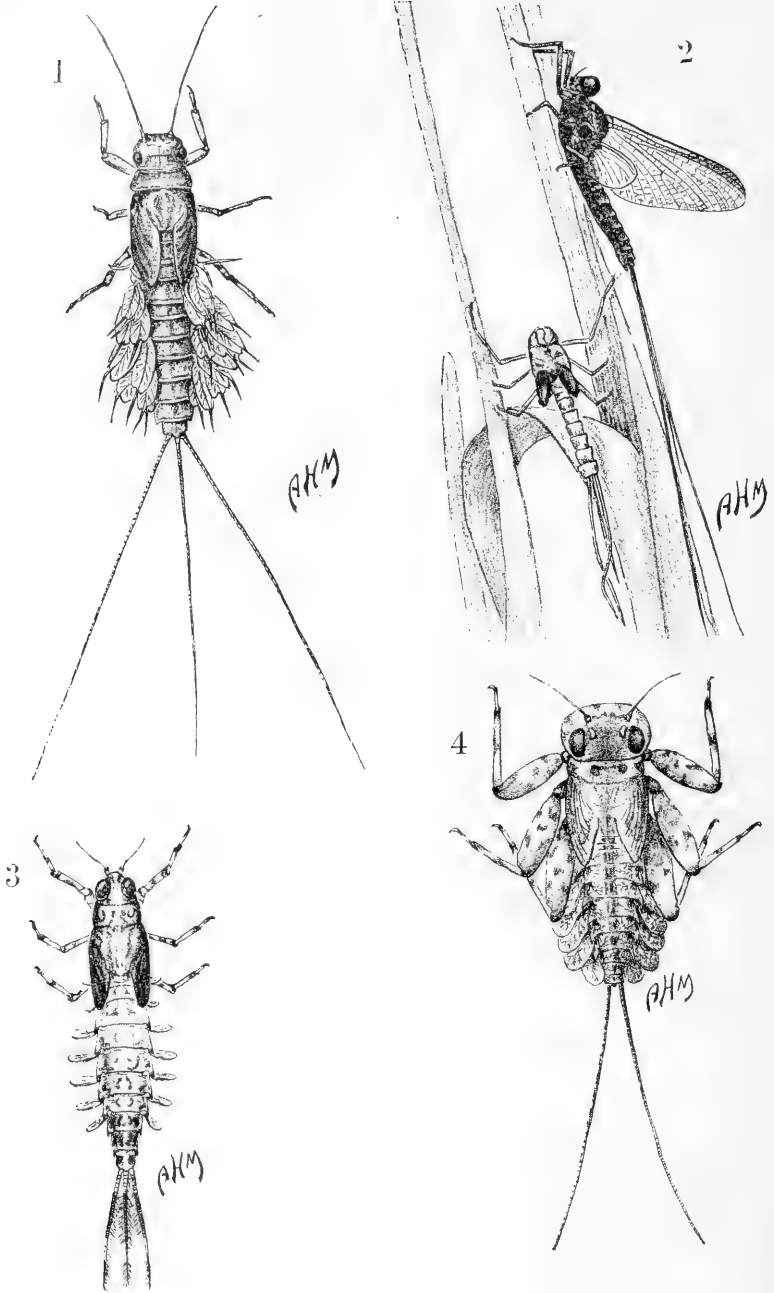

Anna H. Morgan.

5

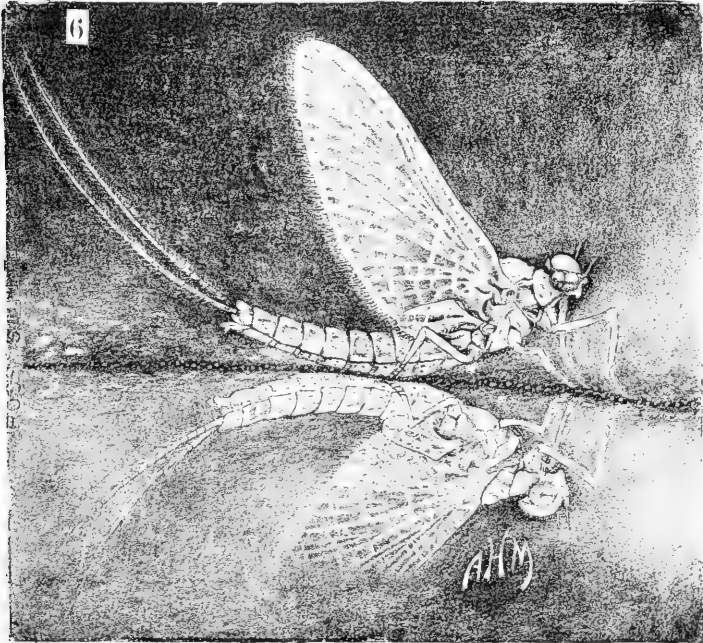

*Anna H. Morgan.*

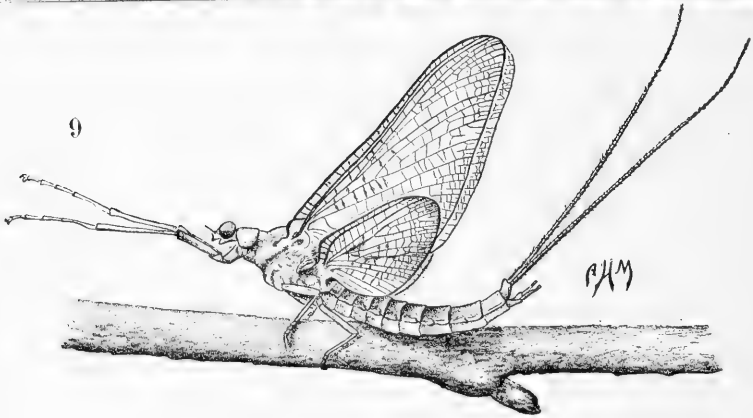
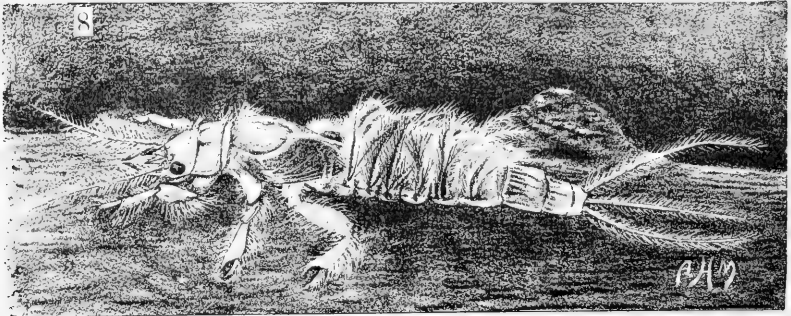
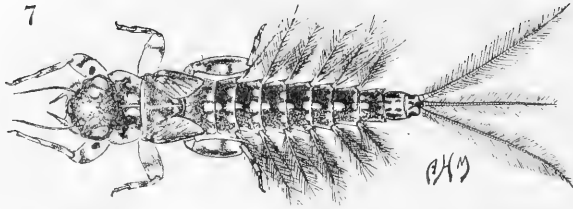



10

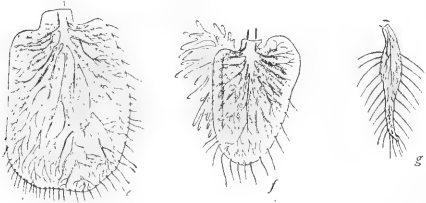
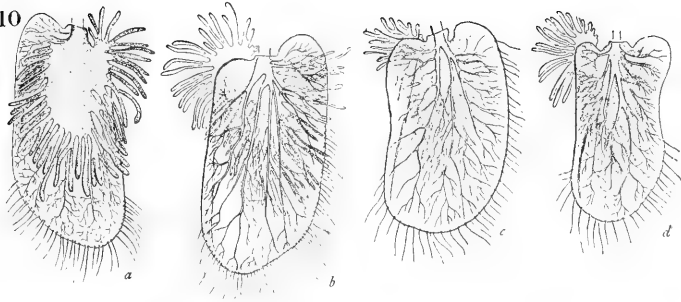

11

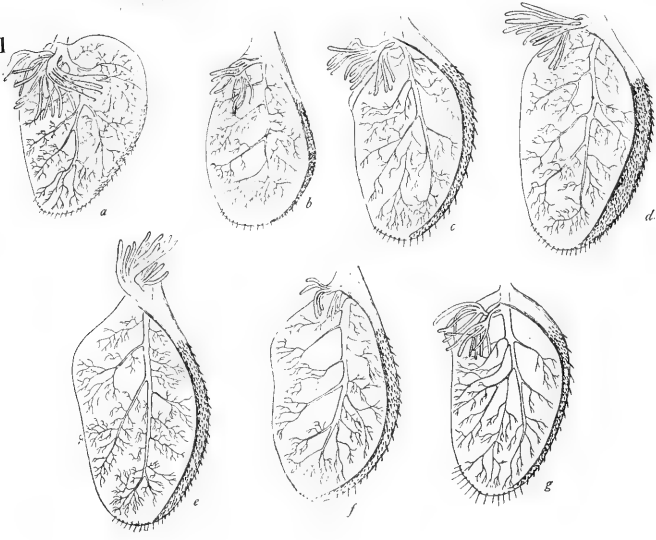

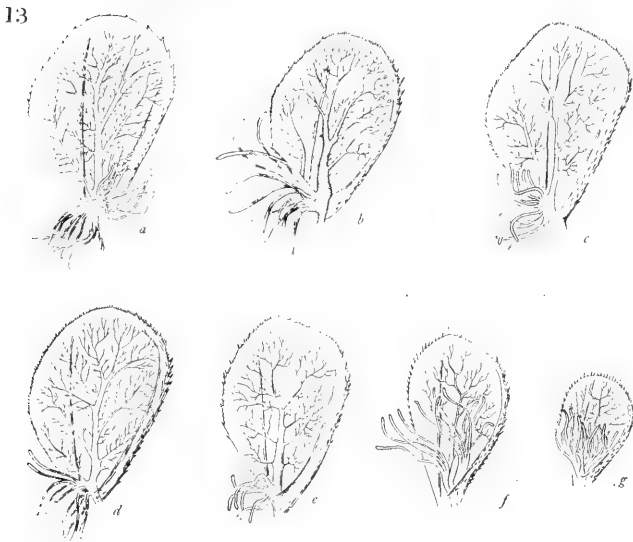

14

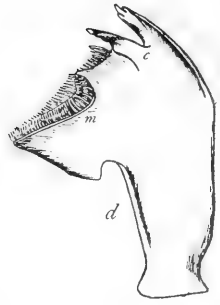
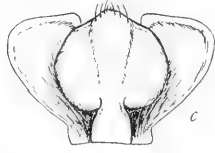
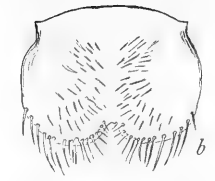
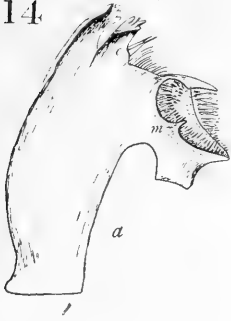

15

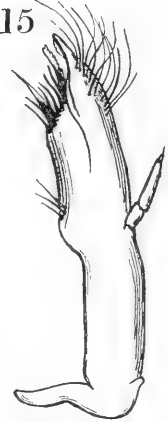

16



17



18



19



20



21



22



23



24



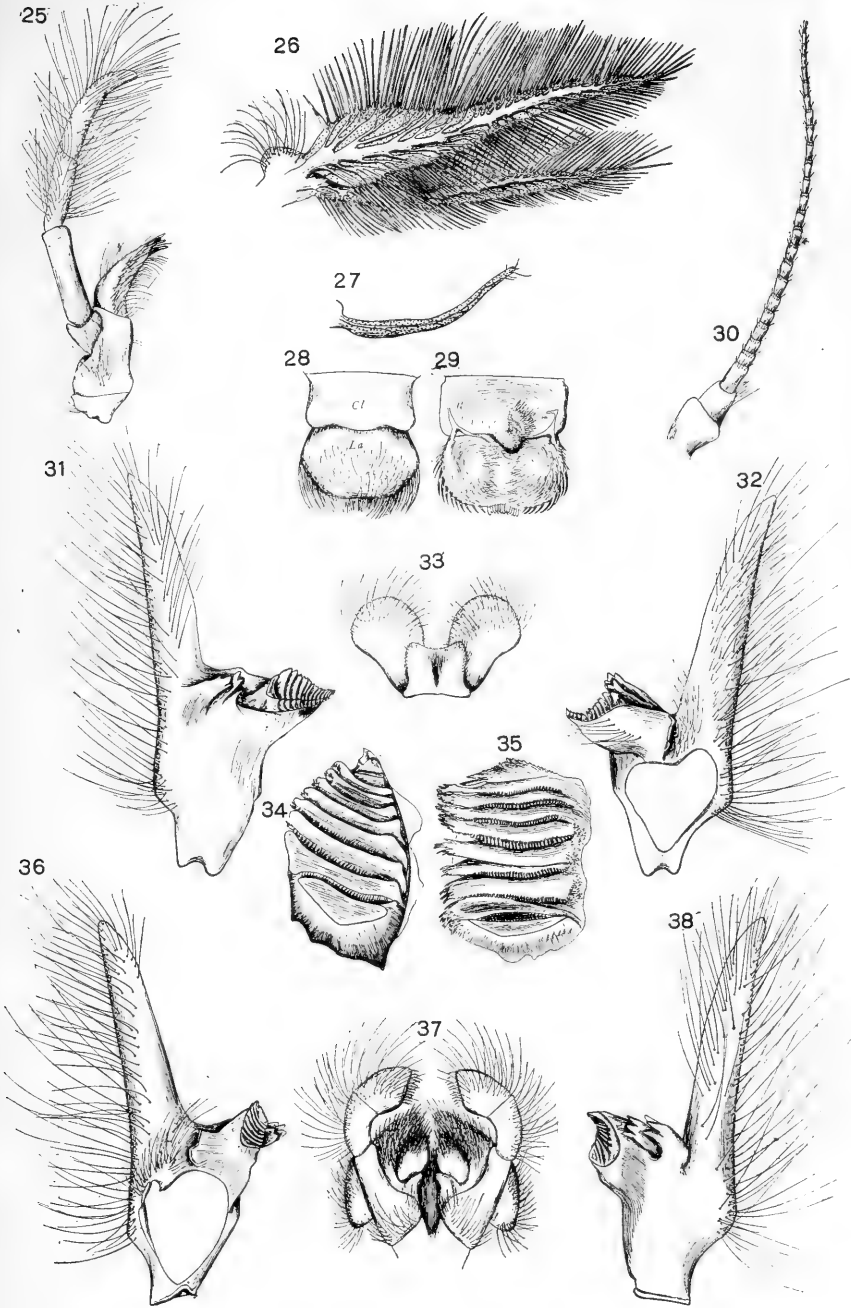

39

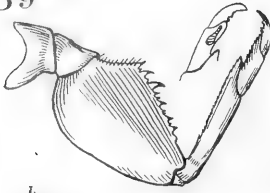

42

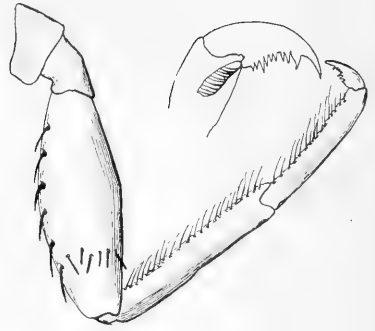

43

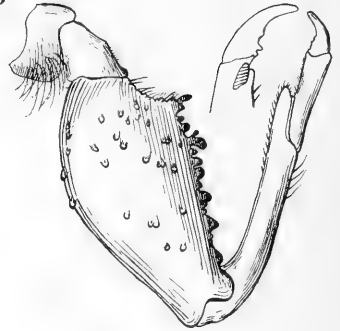

40

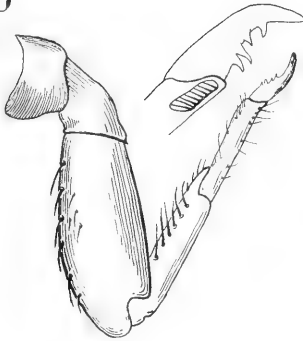

41

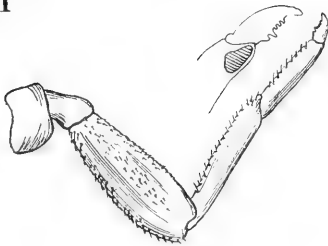

44

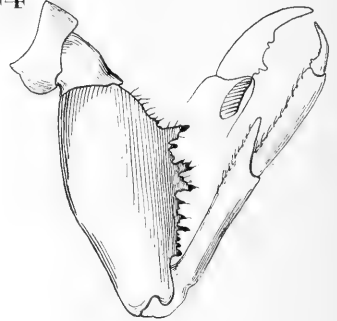

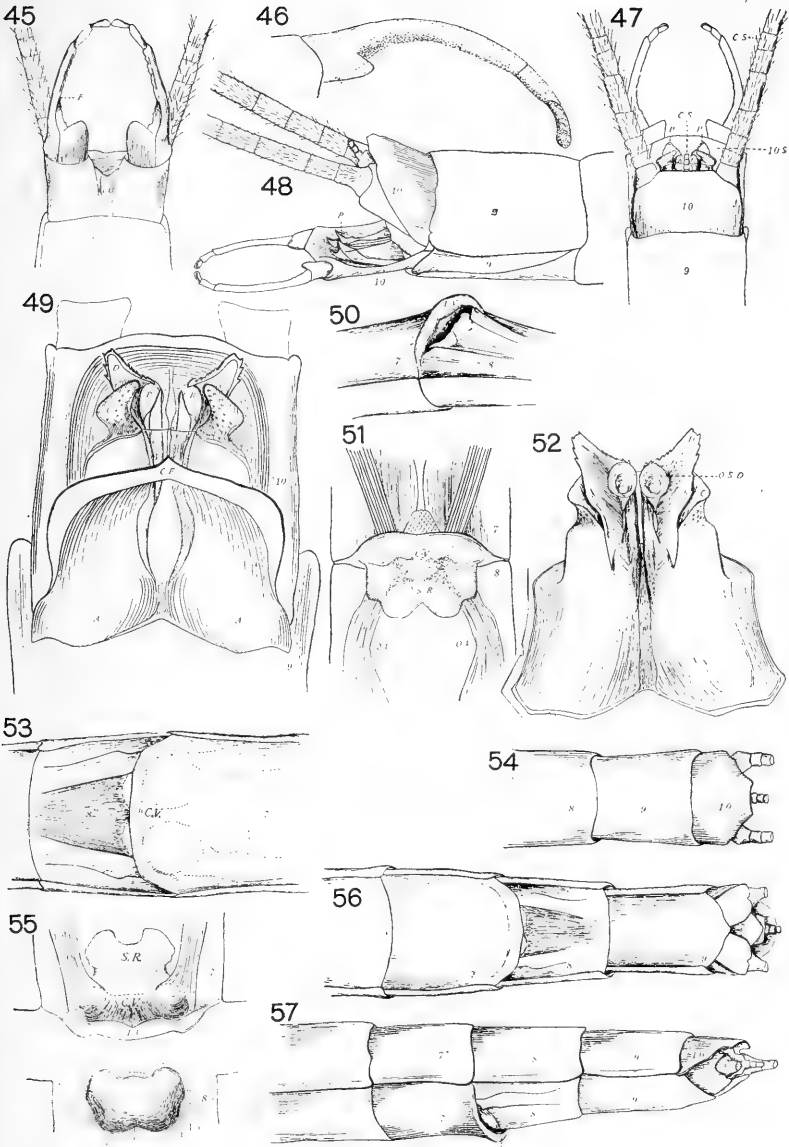

58

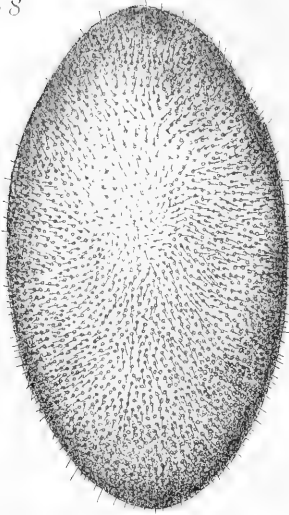

59

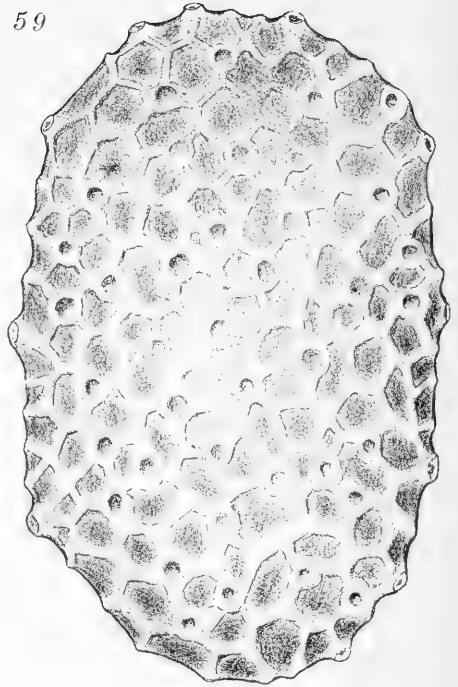

60

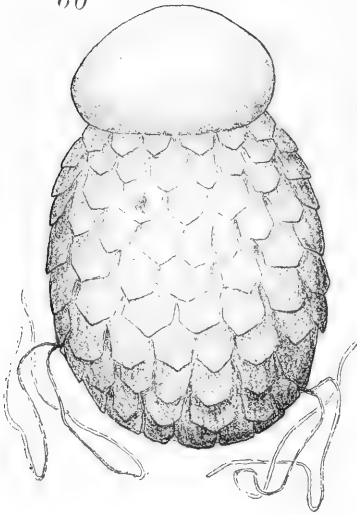

61

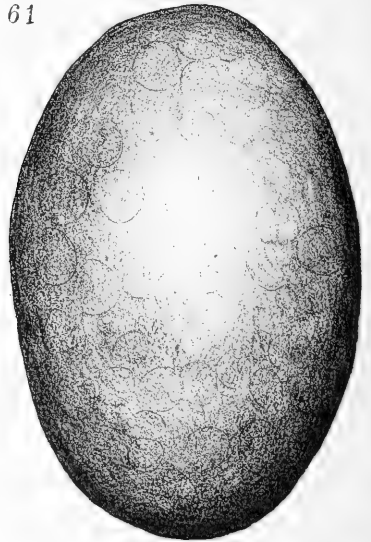



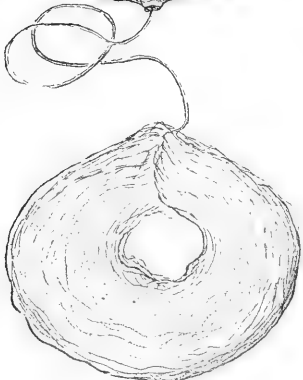
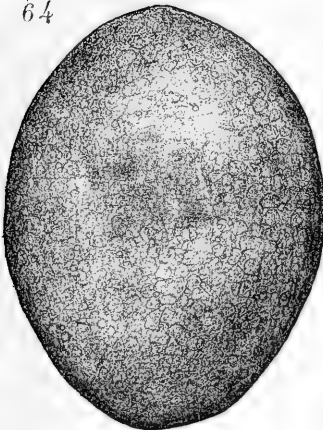
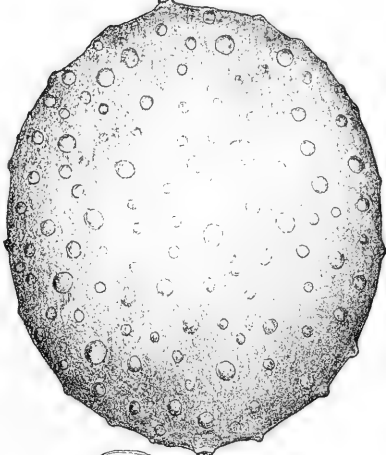
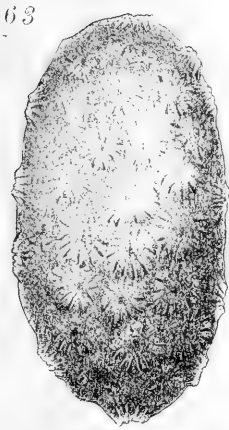
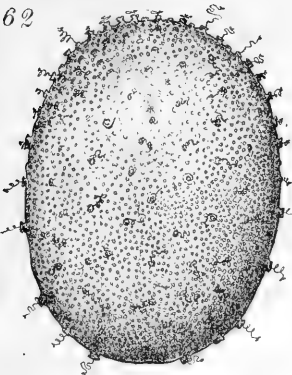

66

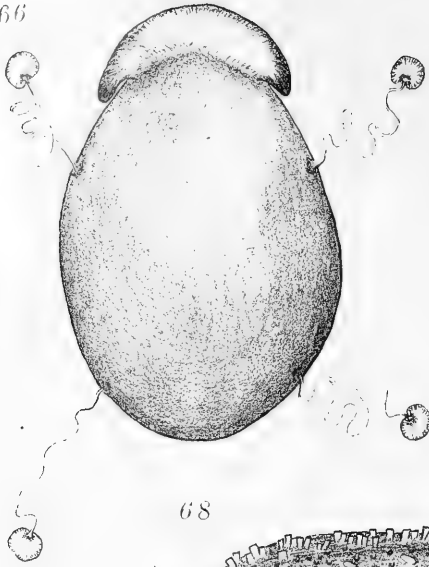

67

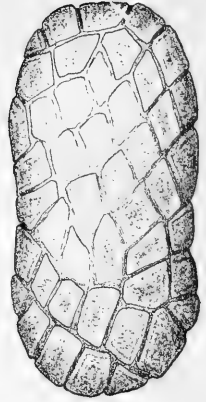

68

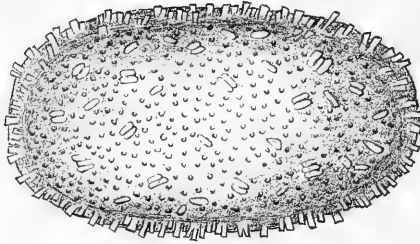

69



70

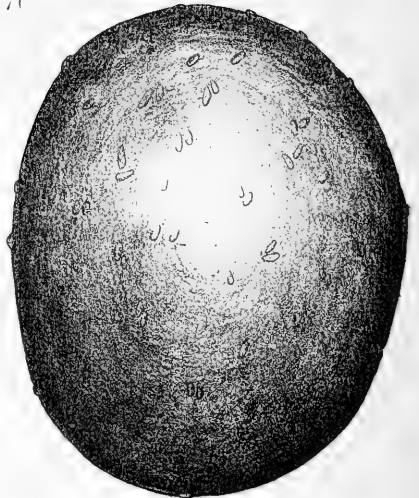

## NOTICE TO MEMBERS AND CONTRIBUTORS.

---

The Annals of the Entomological Society of America, published by the Society quarterly, includes the Proceedings of the Annual meetings and such papers as may be selected by the Editorial Board.

Papers may be submitted to any member of the Editorial Board and should be as nearly as possible in the form desired as final, preferably typewritten, and illustrations must be finished complete ready for reproduction. Plates must not exceed 5x7 inches unless intended to fold. In general, papers to be accepted must be original, complete and previously unpublished and, except in connection with the proceedings, it will not be the policy to publish preliminary announcements or notes. Authors will be allowed fifty reprints gratis and additional copies at cost to the Society.

The Managing Editor is provided with the most recent address of all members on record in the Secretary's office for mailing the numbers of the Annals and hereafter members complaining of the non-receipt of numbers must present their complaint to the Secretary within four months from the date of the mailing of the issue. After that time the numbers will be furnished only at the regular published rate.

Requests for information as to membership and the annual subscription and dues of members may be sent to the Secretary-Treasurer, A. D. MacGillivray, 603 Michigan Ave., Urbana, Ill.

Communications relating to the ANNALS, and all orders for separate copies or reprints should be addressed to the Managing Editor or to

ANNALS OF THE ENTOMOLOGICAL SOCIETY OF AMERICA,  
Biological Building, State Univ., Columbus, Ohio.

## CONTENTS OF THIS NUMBER.

---

MALLOCH, J. R.—A Revision of the Species in <i>Agromyza</i> Fallen, and <i>Cerodontha</i> Rondani. (Diptera).	269
METCALF, Z. P.—The Wing Venation of Fulgoridæ.	341
WICKHAM, H. F.—The Princeton Collection of Fossil Beetles from Florissant.	359
MORGAN, ANNA H.—A Contribution to the Biology of May-Flies.	371

---

The regular annual subscription price for the ANNALS is in the United States, Cuba, Porto Rico, Hawaii and Mexico, \$3.00; Canada, \$3.50; other countries, \$4.00. Checks, drafts or money orders should be drawn payable to ANNALS ENTOMOLOGICAL SOCIETY OF AMERICA, and addressed to Biological Building, State Univ., Columbus, Ohio, U. S. A.

---

---

ANNALS

OF

The Entomological Society of America

---

DECEMBER, 1913

---

EDITORIAL BOARD

J. H. COMSTOCK,  
ITHACA, N. Y.

L. O. HOWARD,  
WASHINGTON, D. C.

C. J. S. BETHUNE,  
GUELPH, ONTARIO, CANADA.

W. M. WHEELER,  
BOSTON, MASS.

C. W. JOHNSON,  
BOSTON, MASS.

P. P. CALVERT,  
PHILADELPHIA, PA.

V. L. KELLOGG,  
STANFORD UNIV., CAL.

J. W. FOLSOM,  
URBANA, ILLS.

HERBERT OSBORN, Managing Editor,  
COLUMBUS, OHIO.

---

PUBLISHED QUARTERLY BY THE SOCIETY  
COLUMBUS, OHIO



# The Entomological Society of America.

FOUNDED 1906.

## OFFICERS 1913.

*President*—C. J. S. BETHUNE .....Guelph, Ont., Canada  
*First Vice-President*—P. P. CALVERT.....Philadelphia, Pennsylvania  
*Second Vice-President*—WM. S. MARSHALL .....Madison, Wisconsin  
*Secretary-Treasurer*—A. D. MACGILLIVRAY.....Urbana, Illinois  
*Executive Committee*—THE OFFICERS, and HERBERT OSBORN, C. P. GILLETTE,  
V. L. KELLOGG, J. G. NEEDHAM, C. T. BRUES, NATHAN BANKS.  
*Committee on Nomenclature*—H. T. FERNALD, E. P. FELT, T. D. A. COCKERELL.

## Price List of Publications.

Annals, Vols. I, II, III, IV and V, complete, each.....	\$3.00
Annals, Separate Parts except as below, each .....	1.00
Annals, Vols. I and II, Part 3, each.....	.50
Annals, Vol. IV, Part IV, each.....	1.50

### REPRINTS FROM VOLUME I.

Proceedings of first three meetings; Constitution, By-Laws and List of Members.....	.25
WHEELER, WM. M.—Polymorphism of Ants.....	.30
OSBORN, HERBERT—The Habits of Insects as a Factor in Classification. ....	.20
SEVERIN, H. H. AND SEVERIN, H. C.—Anatomical and Histological Studies of the Female Reproductive Organs of the American-Saw Fly, <i>Cimbex Americana</i> , Leach.....	.25
FELT, E. P.—Some Problems in Nomenclature.....	.10
HAMMAR, A. G.—On the Nervous System of the Larva of <i>Corydalis cornuta</i> L.....	.25
BRADLEY, J. C.—A case of Gregarious Sleeping Habits among Aculeate Hymenoptera.....	.10
DAVIS, J. J.—Notes on the Life History of the Leafy Dimorph of the Box-elder Aphid, <i>Chaitophorus negundinis</i> Thos.....	.10
HAMBLETON, J. C.—The Genus <i>Corizus</i> , with a Review of the North and Middle American Species.....	.25
GIRAULT, A. A.—Biological Notes on Colorado Potato Beetle.....	.25
GIRAULT, A. A.—A Monographic Catalogue of the Mymarid Genus <i>Alaptus</i> ..	.25
SEVERIN, H. H. and SEVERIN, H. C.—Internal Organs of Reproduction of Male Saw-fly.....	.15
SMITH, C. P.—A Preliminary Study of the Araneæ Theraphosæ of California..	.75
DAVIS, J. J.—Studies on Aphididæ.....	.20
RILEY, W. A.—Muscle Attachment of Insects.....	.15
NEEDHAM, J. C.—Critical Notes on the Classification of the Cordullinæ (Odonata).....	.15
HOWARD, L. O.—A Key to the Species of <i>Prospaltella</i> with Table of Hosts and Descriptions of Four New Species.....	.15
HOOD, J. D.—Two New Species of <i>Idolothrips</i> .....	.10

Address

ANNALS ENTOMOLOGICAL SOCIETY OF AMERICA,

Biological Building, State Univ., Columbus, Ohio.

ANNALS  
OF  
The Entomological Society of America

---

Volume VI

DECEMBER, 1913.

Number 4

---

THE EXTERNAL ANATOMY OF THE SQUASH BUG,  
ANASA TRISTIS DE G.\*

By DANIEL G. TOWER, B. S.  
Amherst, Massachusetts.

INTRODUCTION

In writing this article the chief aim is to endeavor to supply a reference work on the external morphological characters of a typical Heteropterous insect. For this reason the common squash bug has been selected as it is widely distributed, well known as a pest, and is readily obtainable for study.

In order to make the paper as complete as possible the morphologists' and systematists' terms have both been used, except in referring to the wing venation (the systematists' terms being lacking in the fore-wing and the morphologists' in the hind wing).

At this point I wish to express my gratitude to Dr. H. T. Fernald and Dr. G. C. Crampton for their many helpful suggestions and assistance in preparing this paper.

ANATOMY

*Head*

The sclerites of the head capsule of the squash bug are solidly fused together making it impossible to do more than to describe the general regions of which the head is composed. Of these the occiput (occ), (Pl. LV, f. 1.) lies behind the ocelli (oc) and forms the posterior portion of the head surrounding the occipital foramen. It is marked off by a shallow transverse groove, from

---

\* Contribution from the Entomological Laboratory, Massachusetts Agricultural College.

the vertex. The vertex or cranium (ec) comprises the dorsal region in front of the occiput and bears the ocelli. This area is not marked off from the frons (f), which lies above and between the bases of the antennae (ant). The anterior margin of the frons is united with the base of the clypeus or tylus (c).

Below and on either side of the compound eyes (e) lie the genæ (g) while the ventral posterior portion of the head capsule forms the basal plate or gula (gu). The clypeus, as has been previously stated, is fused at its base with the frons, and at this point is narrow, but as it curves forward and downward it widens at its tip to form the base of attachment for the labrum (lbr) from which it is separated by a narrow membranous ring.

The labrum is an elongate triangular sclerite. Its anterior surface is convex, while its posterior surface is flat and contains a groove which lies above the groove on the basal half of the anterior surface of the labium (lab).

On either side of the clypeus is a narrow prolongation of the frons called the fulcrum, jugum or zygum (fr). The fulcra lie close to the lateral walls of the clypeus, hiding them, but are not united with them except at their bases, where they fuse with the head capsule. The fulcrum is shorter than the clypeus, its anterior margin lying behind the swelling of the tip of the clypeus. Its ventral margin extends to the base of the antenna where it fuses with the base of the maxillary laminae (ml).

The maxillary laminae or gena postica lie below the base of the antennae. Their bases are fused with the genæ and their ventral margins are united with the bucculæ (bu), which are chitinous plates projecting from the anterior ventral side of the head on either side of the base of the labium. The bucculæ serve to protect the posterior membranous portion of the base of the labium.

The rostrum, vagina or labium (lab) articulates with the anterior ventral region of the head between the bucculæ and is made up of four segments, the terminal segment at its tip bearing numerous sensory organs. The labium contains, as stated above, a dorsal groove in which lie the setæ (s). The edges of the groove, distal to the overlying labrum, overlap, forming a closed tube, thus giving the enclosed setæ more support (Pl. LVI, f. 8 s.). At its basal end the groove becomes very shallow; the labium becomes filled with muscles, tracheæ and nerves, and the setæ in this portion of the labium gradually come to lie



within the labrum, whose edges meet beneath and confine the setæ (Pl. LVI, f. 8 s. and Pl. LVI, fs. 21-24's). They then pass back through the articulating membrane, which lies between the labrum and clypeus, and between the lateral walls of the clypeus. The walls of the clypeus at its tip, turn under, and their edges interlock forming a narrow pair of supporting lobes above which the setæ pass. Upon emerging from these lobes the maxillary setæ (m) spread apart to receive the tip of the pharynx and the canal from the salivary pump, both of which enter the setæ at this point.

The setæ represent the mandibles (md) and the maxillæ (m). The maxillæ are fluted and interlocked so as to form two tubes, these being the upper or suction canal, and the lower or salivary canal (Pl. LV, f. 2). The mandibles are slightly shorter than the maxillæ and their tips are barbed. Their function is that of piercing the plant tissue and holding the setæ in place, while the tips of the maxillæ, which are acute and fluted, probe the plant tissues, take up the plant juices, and eject the saliva. The setæ, as stated, pass back into the head capsule and separate at their junction with the pharynx, going to either side of it. Their bases widening out form points of attachment for the controlling muscles.

The antennæ (ant) are composed of six segments. The third and fifth are ring joints (Pl. LVII, f. 16, r.), or reduced segments; therefore the antenna as a whole appears to be composed of only four segments. The fifth segment, or second ring joint, allows great freedom of motion to the terminal segment. The second and fourth segments are long and slender. The proximal segment is called the scape or radícula (sa). It is large and has a stalked base, which enlarges at its connection with the head to form a universal joint. The terminal segment is spindle shaped and covered with numerous sensory hairs. The other segments possess sensory hairs, but not as specialized as those of the terminal segment.

The compound eyes (e) are large and composed of many facets, and project prominently from the head. The ocelli are two in number.

The posterior portion of the head or the collum is set into the collar of the prothorax and is joined to it by a membranous neck.

*Thorax*

*Prothorax*.—The prothorax is a large chitinous segment whose sclerites are solidly fused together, with the exception of the episternum and epimeron which are separated for a short distance by the coxal cleft (b).

The notum (no) overlaps the prescutum, scutum, and a portion of the scutellum of the mesothorax dorsally; and the pleural region projects over a portion of the anterior part of the mesothorax laterally (Pl. LV, f. 1 and 4). The tergum or notum is of one piece, its sclerites being indistinguishably fused together. Its anterior portion is more or less irregular due to the attachments of the muscles of the fore leg to its inner surface. The union of the notum and pleuron forms a well defined ridge.

The Pleuron (pl) is divided, as stated above, by the coxal cleft into the epimeron (epm) and episternum (eps). The cleft extends only a short distance into the pleuron terminating in a groove. Above this the pleuron bulges out forming a larger cavity for the expanding muscles of the fore leg. This region of the pleuron is called the omium (om).

The sternum (st) is a small area lying between, and anterior to the coxal cavities, and is indistinguishably fused with the pleuron. The portion of the sternum projecting backward between the coxal cavities is called the mucro (mu). The anterior portions of the coxal cavities are formed by the inner surfaces of the epimeron, episternum, and the sternum; and are closed posteriorly by the extensions of the prothorax epimeron and sternum, together with the anterior portion of the mesosternum.

The legs show the usual five divisions into the coxa (co), trochanter or fulcrum (fr), femur (fe), tibia (t), and tarsus (ta), (Pl. LVI, f. 13). Since the fore legs are typical, although they are proportionately smaller, one description will be sufficient. At the base of the coxa hidden within the coxal cavity is a narrow plate called the trochantin (Pl. II, f. 9 ti). The coxa is a large swollen segment lying largely within the coxal cavity and is freely movable. The trochanter or fulcrum is a small segment which forms a ginglymus articulation with the coxa and is obliquely joined to the side of the femur. The femur is long and more or less spindle shaped; the tibia articulates with it by a ginglymus joint and is long and slender. The tarsus is composed of three segments. The first segment is called

the Metatarsus (meta), and the terminal segment the ungula (u). This bears divergent claws called unguicula (ua) beneath each of which lies a pulvillus (pu) modified to form a concave adhesive pad (Pl. LV, f. 3).

*Mesothorax*.—The mesothorax is attached to the prothorax by the intersegmental membrane, and the two segments are easily separated, thus uncovering the anterior area of the scutellum and the scutum and prescutum. The covered areas, or the scutum and prescutum, are also called the dorsulum.

The scutum (sc) is divided longitudinally by a wide median furrow. In the scutum, on either side of the median furrow are two irregular longitudinal impressed lines (d), which are possibly homologous with the parapsidal furrows of the Hymenoptera. If this be the case, then the area lying between the two last mentioned impressed lines would be the prescutum (psc), while the areas lateral to the lines would be the scutum (Pl. LVI, f. 10).

Lying posterior to the scutum and separated from it by a transverse ridge is the scutellum (sct), which is triangular in outline and projects posteriorly over the metathorax and the first abdominal segment. On the lateral edge of the scutellum is a ridge called the frenum (fm) (Pl. LVI, f. 10).

The postscutellum (psct) of the mesothorax forms the anterior wall of the phragma (phr) situated between the meso and the metathorax, while the prescutum (psc) of the metathorax forms its posterior wall. Both of these sclerites are only slightly visible externally (Pl. LVI, f. 10).

The fore wings are characteristic of the suborder Heteroptera being partly membranous and partly coriaceous. Their bases articulate with the mesonotum by means of small chitinous plates called ossicula or axillaries.

The membranous and coriaceous portions of the fore wings are separated by a more or less broken oblique suture called the sutura membranæ (s-m). The coriaceous portion is marked off into three areas by two longitudinal sutures (Pl. LVIII, f. 19). These areas are as follows: the clavus (cl), which lies next to the mesoscutellum when the wings are in repose; the corium (cr) which lies between the two sutures; and the embolium or costal area (em), which lies beyond the second suture. The first suture or the one which marks off the clavus is called the sutura clavi or anal furrow (s-c). The suture separating the corium from

the embolium is called the median furrow (m-f). The margin of the clavus, which when the wing is at rest lies along the lateral edge of the mesoscutellum, is called the margo scutellaris (m-s), while the margin of the clavus beyond the tip of the mesoscutellum, is called the commissura (cm).

There are three angles in the coriaceous portion, used in classification. These are as follows: the internal angle, angulus internus (a-i) formed by the meeting of the sutura membranae and the sutura clavi; the angulus clavi (a-c), which lies between the sutura clavi and the commissura; and the angulus scutellaris (a-s), which is formed by the meeting of the commissura and the margo scutellaris.

The coriaceous portion of the wing has an inconspicuous venation to which the following names have been given. The costa (ca) is the longest vein, lying nearly parallel to the costal margin of the wing. The subcosta (sca) and radius (ra) lie posterior to the costa, their basal halves being coalesced. Behind or posterior to the coalesced subcosta and radius, lies the median vein (me) connected by a short cross vein (r-m) near its tip with the radial sector. The cubitus (cu) lies within the clavus; and the first anal vein (a) lies along the margo scutellaris except at its base where it extends into the clavus.

The anterior part of the mesopleuron is hidden under the prothorax. It is partially divided into two sclerites, the epimeron and the episternum, by the coxal cleft over the insertion of the mesocoxa. A third plate which is a marked off portion of the epimeron lies at the base of the fore wing and is wholly hidden by the prothorax. It is called the basalar plate (ba). A chitinous plate called the prealar bridge (o) connects the pleuron and the scutum near the juncture of the mesothorax with the prothorax. Below this plate lies the mesothoracic spiracle (sp) in the intersegmental membrane between the meso and prothorax. Posterior to the basalar plate is an invaginated triangular apodeme (ap) whose position is indicated externally by a cavity. A continuation of one of the angles of this cavity marks off part of the dorsal border of the pleuron causing it to appear as a sclerite. A membranous area extends from the base of the fore wing to the prealar bridge, and separates the scutum from the pleuron and its plates.

The sternum is of one piece solidly fused with the episternum. The coxal cavities are formed by the inner surfaces of the

epimeron, episternum and sternum anteriorly, and posteriorly by the anterior margin of the metasternum and metæpisternum.

*Metathorax.*—The notum of the metathorax is well developed and is composed of three sclerites. The prescutum (psc), which has already been described, forms the posterior wall of the phragma between the meso and metathorax, and in its normal position is only slightly visible from the exterior. The scutum (sc) and scutellum (sct) are fused and the visible portions appear as an elongate triangular sclerite on either side of the mesoscutellum which hides the middle portion. The postscutellum (psct) lies behind this sclerite and is fused with it, its central portion being hidden beneath the projecting mesoscutellum.

The pleuron (pl) is partially divided by the coxal cleft into a large epimeron or pleurum and a very small episternum, the latter being indistinguishably fused with the sternum. At the upper end of the cleft lie the two light yellow scent glands (sg) separated by a pit which extends into the body cavity and into which flows the fluid secreted by the glands. Lying above the scent glands and hidden in the folds between the meta and mesothorax is the metathoracic spiracle. On either side of the dorsal margin of the metapleuron is a longitudinal grooved area called the cenchrus (Pl. LV, f. 4, cc and Pl. LVI, f. 10, cc), in which there lies a ridge, located on the ventral side of the costal margin of the fore wing.

The hind wings or alæ (hw) are joined to the metathorax although their bases appear to lie mostly above the mesopleuron when viewed laterally. Their bases articulate with the fused scutum and scutellum, whose posterior margin is continuous with the posterior margin of the wing. The alæ articulate with the metanotum by means of numerous small chitinous plates called ossicula or axillaries.

The wing is wholly membranous and distinctly veined. The venation given is the purely systematic one. The costa primaria (ca-p) is the large vein lying just posterior to and parallel with the costal margin in the basal half of the wing (Pl. LVIII, f. 20). The costa subtensa (ca-s) lies below the costa primaria and is more or less parallel with it. Near the distal end of the costa subtensa is a short incomplete transverse vein which nearly reaches the costa primaria. This is called the Hamus (ha). The distal ends of the costa primaria and subtensa are connected

by a short vein, the costa connectens (ca-c). From the union of the costa primaria and costa connectens the costa apicalis (ca-a) extends outward toward the apex of the wing. Behind the costa apicalis and nearly parallel with it lies an unnamed vein which is usually unbranched although in an abnormal specimen a short branch vein has been noticed arising from it and extending outward between it and the costa apicalis. From the union of the costa subtensa and the costa connectens extends the costa decurrens (ca-d), a strongly curved vein. Behind the costa decurrens lie two nearly straight, short veins called the costa lineatæ (ca-l). Behind the costa lineatæ lie three veins in the anal area, the costa radiantes (ca-r). The first is not attached to the base of the wing while the second and third are so attached.

### *Abdomen*

The abdomen is broadly joined to the thorax and its anterior portion is overlapped by the metathorax to such an extent that the spiracle situated in the pleural region of the first abdominal segment is completely hidden beneath the metapleuron. The first six segments of both male and female bear a pair of spiracles.

The first four and part of the fifth segments of the abdomen show clearly the marking off into four typical regions. The notum (no) is the flat, black, dorsal portion on which the wings rest. The pleural areas or connexivum which form the sides of the trough in which the wings lie when at rest are situated one on either side of the dorsal region, and extend to the prominent lateral edges of the abdomen. The sternal area is that forming the ventral and lateral portions of the abdomen. The spiracles (sp) are located near the dorsal edges of the sternum. The sclerites of the posterior portion of the fifth segment, and of the segments following, are more or less closely fused together and are specialized for reproduction in both males and females.

There are nine segments in the abdomen of the male. The seventh is not visible under normal conditions, but together with a large part of the eighth segment, is retracted within the sixth segment. The seventh segment is highly specialized for this purpose, being merely a collar of chitin which telescopes over the base of the eighth segment. The eighth or genital segment is also highly specialized, its sclerites being solidly

fused together, except dorsally where the chitin is almost membranous just anterior to the rectal cauda (rc). Its shape is also greatly modified. The dorsal aspect presents a large pit or cavity, above which lies the rectal cauda and the genitalia. The chitinized tip of the rectal cauda is the much modified ninth segment. The rectal cauda projects posteriorly from the dorsal wall of the eighth segment, which is called the pygidium (pg). The basal half of the rectal cauda is membranous above and below, but slightly chitinous laterally. Its posterior half, which lies folded and hidden within the basal portion, is membranous except the tips which are chitinized, and open and close as do the edges of a purse. Beneath the basal portion of the rectal cauda lies the œdeagus, those chitinized portions of the male genital organs through which pass the membranous structures connected with the ejaculatory duct. Posterior to the œdeagus lie two movable appendages or styli (1a). The ventral portion of the eighth segment which bears internally the lateral appendages and contains the œdeagus is called the hypopygium (pp).

Dorsally, the abdomen of the female presents ten segments. The tenth, which forms the chitinous lips of the rectal cauda, is hidden within the ninth, except when extruded, and is widely separated from the ninth by the membranous rectal cauda. The dorsal portion of the ninth segment is called the pygidium. Ventrally, the ten segments are not so easily recognizable, especially when the abdomen is extended, as the segments are variously modified for protective and reproductive purposes. Attached to the insides of the dorsal and ventral portions of the eighth abdominal segment are two pairs of chitinous appendages, the lateral appendages or styli, armed with stiff spines or hairs. These lie above and protect the soft portions of the genitalia when in repose. These appendages may function as claspers in copulation, but actual observation of this function will be necessary to determine this point. The ventral portion of the eighth abdominal segment is called the hypopygium.

## BIBLIOGRAPHY.

1861. **Fieber, Franz Xaver.** Die Europäischen Hemiptera.  
 1883. **Geise, Otto.** Die Mundtheile der Rhynchoten, Archiv f. naturg. vol. XLIX, pp. 315-373, pl. x.  
 1885. **Wedde, Hermann.** Beiträge zur Kenntniss des Rhynchotenus, Archiv f. naturg. (2) LI, pp. 113-143, pl. vi and vii.  
 1890. **Sharp, David.** On the structure of the Terminal Segment in Some Male Hemiptera. Trans. of the Ent. Soc. of Lond. pp. 399, pl. xii, xiii, xiv.  
 1892. **Smith, John B.** The Structure of the Hemipterous Mouth. Science vol. XIX, No. 478, pp. 189, fig. 1-5.  
 1896. **Marlatt, C. L.** The Hemipterous Mouth. Ent. Soc. of Wash. vol. 3, pp. 241-250, fig. 21-23.  
 1899. **Heymons, Richard.** Beiträge zur Morphologie und Entwicklungsgeschichte der Rhynchoten, Nova. Acta. vol. LXXIV, pl. xv-xvii.  
 1908. **Comstock, J. H. and Needham, J. G.** The Wings of Insects. Amer. Natural. vol. XXXII, p. 252.  
 1908. **Chittenden, F. H.** The Common Squash Bug. U. S. D. A. Bureau of Ent., cir. 39.  
 1911. **Muir, F. and Kershaw, J. C.** On the Homologies and Mechanism of the Mouth-parts of Hemiptera. Psyche, vol. XVIII, No. 1, p. 1, pl. 1-5.  
 1911. **Bugnion, E. and Popoff, N.** Les Pièces Buccales des Hémiptères (Première Partie). Arch. de Zoo. Exp. et Général. 5e Série, Tome vii, pp. 643 à 674, pl. xxv à xxvi.  
 1912. **Muir, F. and Kershaw, J. C.** The Development of the Mouthparts in the Homoptera, with Observations on the Embryo of Siphanta. Psyche, vol. XIX, No. 3, p. 77, fig. 1-4.

## LETTERING OF FIGURES.

Numbers 1-10 denote number of the segment. Subscripts 1, 2, 3, pro-, meso-, metathorax, respectively.	e	eyes.
a	em	embolium.
a-c	epm	epimeron; mesothoracic epm = scapula; metathoracic epm = pleurum.
a-i	eps	episternum.
a-s	f	frons.
ab	fe	femur.
ant	fm	frenum.
ap	fr	fulcrum, jugum or zygum.
b	fw	fore wing.
ba	g	<del>gula</del> gena ; gu = gula.
bc	hw	hind wing, ala.
bu	la	lateral appendages, styli.
c	lab	labium, rostrum, vagina.
ca	lbr	labrum.
ca-a	m	maxillary setæ.
ca-c	m-f	median furrow.
ca-d	m-s	margo scutellaris.
ca-l	md	mandibular setæ.
ca-p	me	median vein.
ca-r	ml	maxillary laminæ, gena postica.
ca-s	mta	metatarsus.
cc	mu	mucro.
cl	n	salivary canal.
cm	no	notum.
co	o	prealar bridge.
cr	oc	ocelli.
cu	occ	occiput.
d	om	omium.



p	suction canal.	s-m	sutura membranæ.
pg	pygidium.	sa	scape.
phr	phragma.	sc	scutum.
pl	pleuron; abdominal pleuron = connexivum.	sca	subcosta.
pp	Hypopygium.	sct	scutellum.
psc	prescutum.	sg	scent glands.
psct	postscutellum.	sp	spiracles, stigmata.
pu	pulvillus.	st	sternum.
r	ring joints.	t	tibia.
r-m	connecting vein between ra and me.	ta	tarsus.
ra	radius.	ti	trochantin.
rc	rectal cauda.	tr	trochanter, fulcrum.
s	setæ.	u	ungula.
s-c	sutura clavi, anal furrow.	ua	unguicula.
		v	vertex, cranium.

## EXPLANATION OF PLATES.

## PLATE LV.

- Fig. 1. Lateral view of head, thorax and first segments of the abdomen.  
 Fig. 2. Cross section of the mandibular and maxillary setæ.  
 Fig. 3. Lateral view of a tarsal claw and the adhesive pad or modified pulvillus lying beneath it.  
 Fig. 4. Lateral view of the meso- and metathorax, as seen looking obliquely backward, the prothorax being removed and the wings raised and the abdomen abnormally extended to show the spiracle on the first segment.  
 Fig. 5. Dorsal view of the abdomen. The female genitalia are not extended.

## PLATE LVI.

- Fig. 6. Maxillary setæ showing fluted and piercing tips; (see fig. 2 cross section of maxillary setæ).  
 Fig. 7. Mandibular setæ showing barbed and piercing tips.  
 Fig. 8. Cross section of labium at the tip showing how the setæ are supported.  
 Fig. 9. Coxa and trochantin.  
 Fig. 10. Dorsal view of the meso- and metathorax with the wings extended.  
 Fig. 11. Lateral view of the male genitalia extended.  
 Fig. 12. Ventral view of the male genitalia normally retracted.  
 Fig. 13. Typical leg.  
 Fig. 14. Lateral view of female genitalia normally retracted.

## PLATE LVII.

- Fig. 15. Dorsal view of male genitalia extended.  
 Fig. 16. Antenna.  
 Fig. 17. Ventral view of the insect showing female genitalia.  
 Fig. 18. Lateral view of female genitalia extended.

## PLATE LVIII.

- Fig. 19. Fore wing.  
 Fig. 20. Hind wing.  
 Figs. 21-24. More or less diagrammatic.  
 Fig. 21. Cross section of second segment of the labium, showing the position of the setæ.  
 Fig. 22. Cross section at the tip of the first segment of the labium, showing the position of the setæ.  
 Fig. 23. Cross section at about the middle of the first segment of the labium, showing the position of the setæ.  
 Fig. 24. Cross section at the base of the labrum, showing how the setæ are supported.

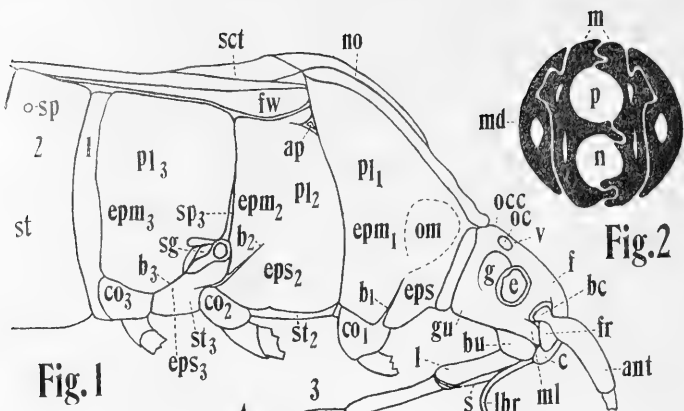

Fig. 1

Fig. 2

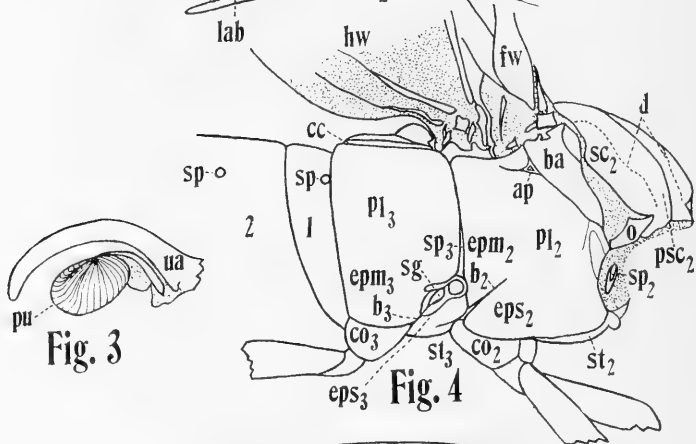

Fig. 3

Fig. 4

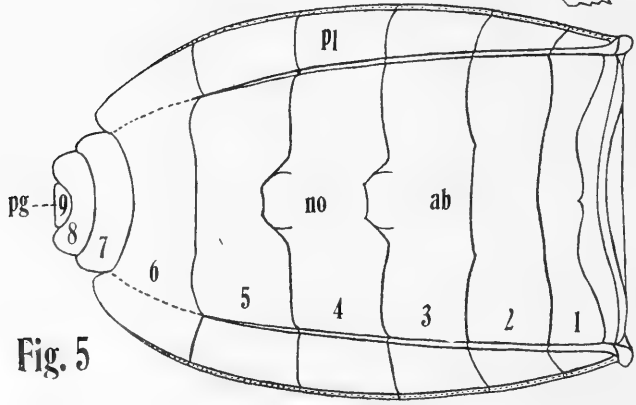

Fig. 5



Fig. 6

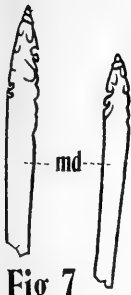

Fig. 7

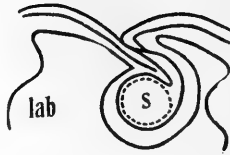

Fig. 8



Fig. 9

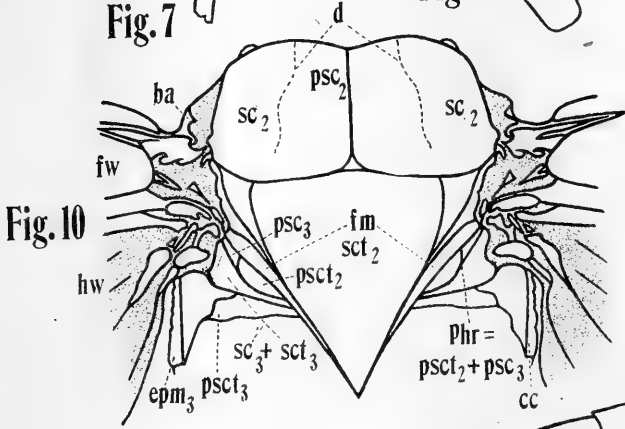

Fig. 10

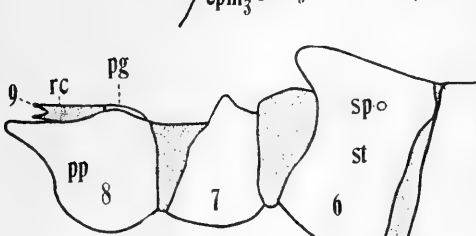

Fig. 11

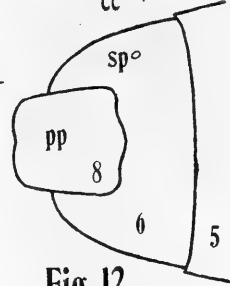

Fig. 12

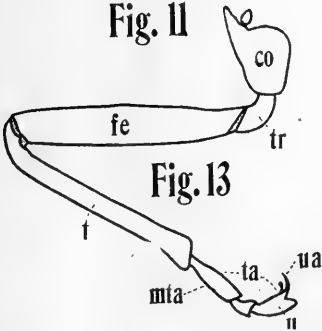

Fig. 13

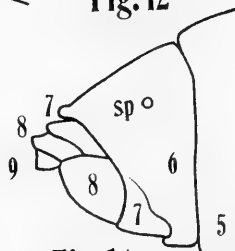

Fig. 14

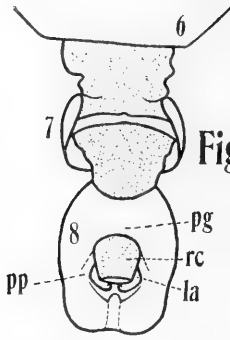

Fig. 15

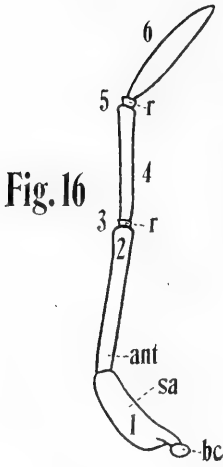

Fig. 16

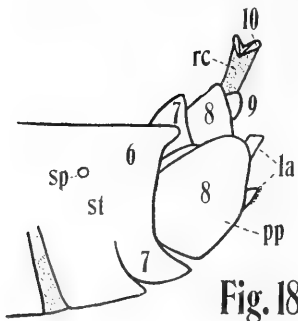

Fig. 18

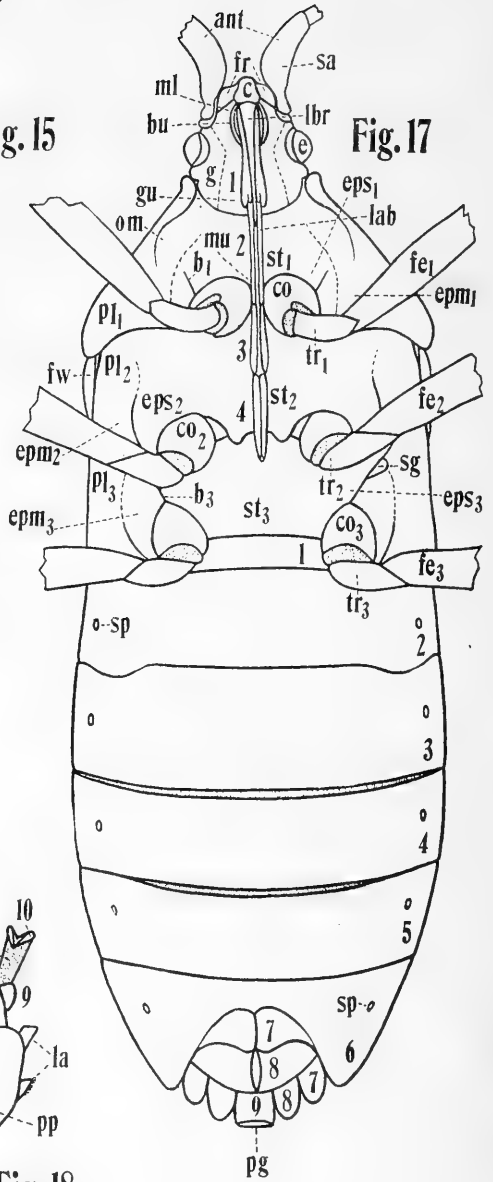

Fig. 17

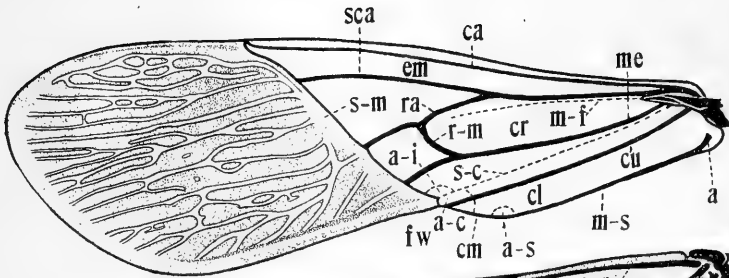

Fig. 19

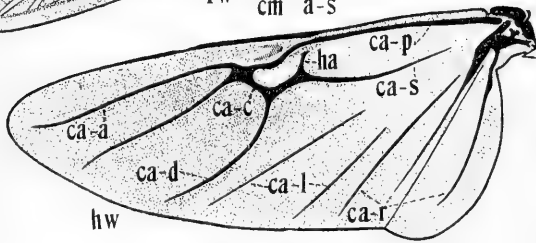

Fig. 20

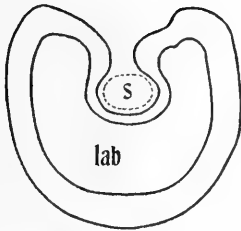

Fig. 21

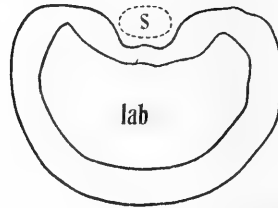

Fig. 23

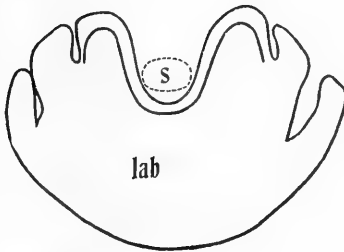

Fig. 22

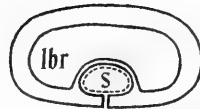

Fig. 24



## THE DIPTERAN FAUNA OF BERMUDA.

By CHARLES W. JOHNSON.

Since publishing a list of the Diptera of Bermuda in 1904, (Psyche, vol. XI, pp. 76-80), I have received a number of specimens from Professor Trevor Kincaid, collected in the summer of 1905, and from Mr. Frank Morton Jones, collected December, 1908-May, 1909, and Dr. Reynold A. Spaeth, collected in the summer of 1910. The material thus obtained at various seasons of the year together with the notes kindly furnished by Mr. Jones, greatly increase our knowledge of the Diptera of the Islands. The study of this material has brought out many interesting points in distribution, some of the species derived from the mainland having become either slightly or decidedly differentiated.

The previous list contained about fifty species. Little of the data has been repeated, although all of the species are included in the following list, which contains about ninety-five species.

### TIPULIDAE.

**Tipula costalis** Say. "This fly was abundant at Paget Marsh in February and March, but seemed to completely disappear later." (F. M. Jones).

**Dicranomyia liberta** Osten Sacken. July 7, at light, (Kincaid), Feb. 14 (F. M. Jones).

**Gonomyia (Leiponeura) pleuralis** Will. This seems to be the most common Tipulid and the one previously recorded as *Dicranomyia distans*, Osten Sacken. It was taken by Professor Kincaid, July 5 and 20, and by Mr. F. M. Jones, Feb. 19 and May 6 and 8.

**Limnophila insularis** sp. nov. Fig. 2.

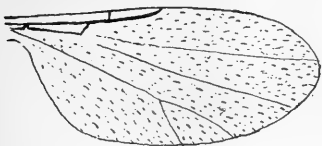

Fig. 1.

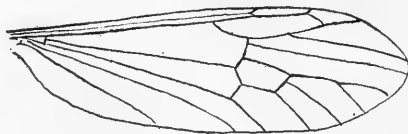

Fig. 2.

This species has a general resemblance to *L. recondita* Osten Sacken. The antennæ in both sexes are of equal length, light yellow, flagellum dark brown, the verticilli much shorter than in *L. recondita*. Head blackish, covered with a greyish bloom. Thorax shining brown, pleura dull yellow with a greyish bloom. Abdomen dark brown,

genitalia yellow. Halteres yellow, knob somewhat infuscated. Legs yellowish, tarsi brownish toward the ends. The wings are noticeably shorter and broader toward the base than in *L. recondita*, the præfurca is shorter and the marginal cross vein at the middle of the anterior branch of the second vein is close to the tip of the first longitudinal vein. Length, ♂ 6mm. ♀ 7mm.

Two specimens. ♂, March 10, ♀, May 1, 1909, (F. M. Jones).

PSYCHODIDÆ.

*Psychoda alternata* Say. Nine specimens were received from Mr. Jones. These were collected by Mr. Mowbray, May 15.

*Psychoda* sp. A larger species was collected by Prof. Kincaid and retained by him for study.

CHIRONOMIDÆ

*Chironomus cristatus* Fabricius. July 26 (Kincaid); Paget Marsh, March 10, (F. M. Jones); near Hamilton, June 26 (Spaeth).

*Orthocladius* sp. July 15 (Kincaid).

*Metricnemus knabi* Coquillett. Eight specimens, February 1 (F. M. Jones).

*Ceratopogon fur* sp. nov. Fig. 1.

Female: Head black, proboscis brown, palpi black, antennæ black, covered with a thick grayish pubescence, apparently with fourteen joints. Thorax black, subshining, hairs grayish, scutellum dark brown, abdomen dull black, thickly covered with grayish hairs. Legs brown, tip of the tarsi and claws black, posterior metatarsi as long as the following joints. Halteres black, the stalks short and thick, the knobs proportionately large. Wings smoky, strongly pubescent, venation as shown in the figure, the third and fourth longitudinal veins obsolete toward the basal portion of the wing. Length, Imm.

Two species, Warwick Marshes, April 16 (F. M. Jones).

The two specimens were attached to a small dragon fly, (an Agrionid); with the mouth parts extended into the sutures near the base of the wings apparently in the act of biting. This is the second time that the writer has seen a *Ceratopogon* attached to an insect. The first example was also taken by Mr. Jones, the flies being attached to the wings of a *Chrysopa*. This specimen was loaned to Dr. E. P. Felt in connection with his studies of the Cecidomyiidae, as a species of the latter family has been recorded by Mrs. Annie T. Slosson as also attaching itself to the wings of a *Chrysopa*. (Ent. News, VII, 238, 1896).

*Ceratopogon* sp. July 12 and 29 (Kincaid).

CULICIDÆ.

*Stegomyia calopus* Meigen, (*Stegomyia fasciatus* Fabr.) The "yellow fever mosquito," June 25-29 (Kincaid); Jan. 22 and Feb. 18, May 6, and 10, 1909 (F. M. Jones).

*Aedes sollicitans* Walker, (*Culex sollicitans* Walk.). The salt marsh mosquito, July 6-12 (Kincaid); Walsingham, Feb. 16, Apr. 8 (F. M. Jones).



**Aedes taeniorhynchus** Wiedemann. (*Culex taeniorhynchus* Wied.).  
July 7-23 (Kincaid).

**Culex quinquefasciatus** Say, (*C. fatigans* of Theobald not Wiedemann;  
*C. cubensis* Bigot). Record by Theobald from collections made  
by Dr. Eldon Harvey, July 1899.

MYCETOPHILIDÆ.

**Sciara** sp. June 25 (Kincaid).

CECIDOMYIDÆ.

**Cecidomyia** sp. June 25 (Kincaid).

**Cecidomyia** sp. June 25 (Kincaid).

BIBIONIDÆ.

**Dilophus breviceps** Loew. Warwick Swamp, April 16, (♂ ♀). "In  
sweep net, in great numbers on one occasion only." (F. M. Jones).

**Scatopse pygmaea** Loew. June 28 and 30 (Kincaid).

**Scatopse atrata** Say. Recorded by Prof. Verrill.

STRATIOMYIDÆ.

**Hermetia illucens** Linne. July 1 (Kincaid); May 13 (F. M. Jones).

**Odontomyia bermudensis** sp. nov.

Female: This species is closely related to *O. cincta* Oliv. and might be considered by some only a variety, but the apparent constancy of the seven specimens before me seems to warrant their separation. The two principal characters which readily distinguish this species are the conspicuous black stripes extending from the humeri to the base of the wings, dividing the green lateral stripes of the thorax from the green pleura, and the dark brown color of the larger vein, this color also extending over the costal and marginal cells and the base of the wing. Minor characters are the greater amount of black on the head, the black of the vertex being often connected with the large black orbital spots of the front, from which extend narrow curved lines to the frontal suture, and a narrow frontal stripe, which is also often present. The black markings of the abdomen are much larger, covering fully two thirds of the surface, while in *O. cincta* the black rarely exceeds one half. Six of the specimens have a dark yellow scutellum, but this may be a discoloration, as it occasionally appears in *O. cincta*. Length 10 to 12mm.

Six specimens, May 9 and 11 (Jones); one specimen, July 26 (Kincaid). "Not rare on the flowers of wild carrot, especially along the borders of the Warwick Marshes" (F. M. Jones).

TABANIDÆ.

**Tabanus atlanticus** sp. nov.

Female: Face white with white hairs, above the base of the antennæ slightly yellowish; front with grayish pollen and brown hairs, callosity large, shining black, with a short, slightly roughened line extending upwards; palpi light yellow with black hairs, proboscis brown; antennæ yellow, with tufts of black hairs on the upper and of white hairs on the under sides of the first and second joints, third joint not angulate, annuli brown. Thorax gray with four obscure

brown stripes, hairs whitish; pleura mottled with bluish-black and covered with whitish pollen and hairs; scutellum grayish. Abdomen brown with a lighter posterior margin on each segment, the entire surface with a white pubescence. Legs yellow, under side of the posterior femora and tips of all the tibiae and tarsi brown, front coxae with long, white hairs; halteres light yellow. Wings hyaline, stigma and cross-veins clouded with brown. Length, 13mm.

The ♂ differs but little from the ♀, except that the facets on the upper two-thirds of the eye are double the size of those on the lower third. The stripes on the thorax are obsolete. Length 10mm.

Three specimens collected by Professor Kincaid, July 10 and 30.

**Tabanus nigrovittatus** Macquart.

In writing to Mr. Jones regarding a larger horse-fly than this species, he says: "This is undoubtedly the 'large horse-fly' you asked me to look out for; the carriage-drivers assured me that no larger species occurs here. It is said to be locally abundant in the summer time, but up to May 20 I saw only one living example; the other specimen I got from a local collector who confirmed the drivers' statement." It seems, therefore, probable that the reference to a larger species, (*Psyche* vol. XI, p. 77) applies also to this species.

SCENOPINIDAE.

**Scenopinus nubilipes** Say. One specimen, May 15 (F. M. Jones).

ASILIDAE.

**Asilus?** sp. Recorded by Professor Verrill.

DOLICHOPODIDAE.

**Sciapus chrysoprasius** Walker. Not rare, March 20, 30 and May 12 (F. M. Jones).

**Sciapus pallens** Wiedemann. Three specimens, April 17, May 18 and 19, resting on the white walls. (F. M. Jones).

**Diaphorus contiguus** Aldrich. Seven specimens, June 30 to July 26 (Kincaid).

**Chrysotus picticornis** Loew. Three specimens July 15 (Kincaid). Common. Spanish Point, July 5 (Spaeth).

**Chrysotus bermudensis** sp. nov.

Front shining green, face with silvery white pollen; antennæ black, small. Thorax and scutellum shining green, slightly covered with a yellowish pollen; pleura greenish black, with whitish pollen. Abdomen shining with a narrow bronze band at the base of each segment. Legs including the front coxæ yellow, middle and posterior coxæ black; a preapical band on the posterior femora, and the extreme tips of the tarsi dark brown. Halteres, tegulæ and cilia light yellow, wings grayish hyaline. Length, 2mm.

Three females, June 20, July 26 (Kincaid). Holotype in the author's collection; one paratype in the Museum of Comparative Zoology. This species is closely related to *C. pallipes* Loew, but seems readily separated from that species by the dark preapical band on the posterior femora.

## PIPUNCULIDAE.

- Pipunculus insularis** Cresson, (Trans. Amer. Ent. Soc., vol. 36, p. 317, 1911). Hamilton parish, May (S. Brown); July 29 (Kincaid); Agar's Island, June 18, and Spanish Point, July 5 (Spaeth).
- Pipunculus albisetia** Cresson, (Trans. Amer. Ent. Soc., vol. 36, p. 318, 1911). Hamilton Parish, May. (S. Brown); Jan. 27 (F. M. Jones).
- Allograpta obliqua** Say, "Abundant throughout the winter," Dec. 11 to Jan. 25 (F. M. Jones); Agar's Island, June 18 (Spaeth).
- Toxomerus marginatus** Say. (*Mesogramma marginatum* Say, of the previous list). "Very abundant and present throughout the winter and spring (Dec. 8 to May 3). A specimen was bred April 1, from a larva found in the flowers of the Bermuda blue-eyed grass." (F. M. Jones). On the road from Hamilton to Grasmere (Spaeth). The larvae are aphidivorous.
- Eristalis tenax** Linne. "The first specimen was taken February 18; afterwards not rare on flowers, but never abundant." (F. M. Jones).
- Eristalis æneus** Scopoli. (*Lathyrrophthalmus æneus* Scop.). "Most abundant on flowers along the cliffs of the south shore, where it was present throughout the winter" (F. M. Jones). Specimens bear the following dates: December 14, 24; January 19; February 6 and March 4.

## SARCOPHAGIDAE.

- Sarcophaga georgina** Wiedemann? Both Professors Walker and Verrill referred the large flesh fly of the Island to *S. carnaria* Linne. Among the series collected by Messrs. Davis, Kincaid and Jones there is not a specimen referable to that species. They represent the large species with reddish genitalia which I have referred doubtfully to *S. georgina*.
- Sarcophaga assidua** Walker. Numerous specimens agree with the description of this species. Feb. 24, April 16 and May 5 (F. M. Jones); Spanish point, July 5 (Spaeth); July 6 (Kincaid).
- Sarcophaga** sp? Probably two closely related species. The present unsatisfactory condition of our Sarcophagidae precludes the possibility of accurately determining the species.
- Helicobia helicis** Townsend. Common, April 18 and 26 (F. M. Jones). Spanish Point, July 5 (Spaeth).
- Sarcophaga** sp. Recorded by Dr. Dahl. I was in hopes of finding the common *S. imbecilla* v. d. W. of the West Indies among the material studied.

## MUSCIDAE.

- Musca domestica** Linne. The common house-fly is abundant throughout the year. June 20 (F. M. Jones); Agar's Island, June 18, and Spanish Point, July (Spaeth).
- Stomoxys calcitrans** Linne. The biting house fly or cattle fly. Abundant with the common house-fly, June 20 (F. M. Jones); Agar's Island, June 18 (Spaeth); July 11 (Kincaid).
- Synthesiomyia brasiliiana** B. & B. July 29 (Kincaid).
- Calliphora vomitoria** Linne. Recorded by Prof. Verrill.

**Lucilia sericata** Meigen. Abundant. Dec. 25 to May 12 (F. M. Jones); July 12-29 (Kincaid); Spanish Point, July 5 (Spaeth). *L. latifrons* Schiner is a synonym.

**Lucilia caesar** Linne. Recorded by Prof. Verrill.

**Lucilia problematica** sp. nov.

Male: Front linear as in *L. caesar*, black, orbits whitish pollinose; face black, whitish pollinose, the oral margins and antennæ reddish brown, arista black. Thorax and abdomen bronze black shining, with a slight whitish pollen especially on the sides and on the pleura. Two post-acrosticals. Femora and tibiæ brown and the tarsi blackish. Squamæ and halteres yellow, wings brownish hyaline. Length 7mm.

Female: Similar to the male, front, as in *L. caesar*, one-third the width of the head.

Holotype June 30 (Kincaid); allotype March 1899 (Montgomery), in the author's collection. This interesting species has been in my collection for some time awaiting more material. The first specimen (♀, antennæ wanting) was collected by Mr. Thomas L. Montgomery in March, 1897. A teneral specimen (♂) was taken by the late C. Abbott Davis, July 11, 1903. These were submitted to the late D. W. Coquillett at the time I was preparing my previous list, but he declined to name them without more material. The third specimen (♂) was taken by Prof. Kincaid, June 30, 1905, and a fourth specimen (♀ teneral) by Mr. Frank M. Jones, March 1, 1909. It is close to *L. caesar* in every respect but color; the entire absence of green or blue, however, seems to preclude placing it in that species. I had hoped that a larger series would show variations approaching that species, but while *L. caesar* was mentioned by Prof. A. E. Verrill, the large series of *Lucilia* brought from the Islands by Messrs. Montgomery, Davis, Kincaid and Spaeth, contained only *L. sericata*.

#### ANTHOMYIDAE.

**Ophyra aenescens** Wiedemann. July 6 (Kincaid); December 26 (F. M. Jones).

**Fannia pusio** Wied. (*F. femorata* Loew) May 9 (F. M. Jones); July 6 (Kincaid).

**Fannia polychæta** Stein. This is based on *Anthomyia lepida* Meig., recorded by J. Matthew Jones in 1876. It is a doubtful species, referred with a question to this species.

**Limnophora narona** Walker. (*L. cyrtoneurina* Stein) collected by C. A. Davis, July 14.

**Mydæa** sp? One imperfect specimen, July 17 (Davis).

**Phyllogaster cordyluroides** Stein. June 30 and July 12 (Kincaid).

**Phorbia fusciceps** Zetterstedt. Common, December 26 (F. M. Jones); June 30 and July 29 (Kincaid); Agar's Island, June 18; on the road from Hamilton to Grasmere, June 26; Spanish Point, July 5 (Spaeth). This species infests onions and other vegetables, and is undoubtedly the fly referred to by Verrill as "*Anthomyia ceparum*," "onion fly."

**Coenosia** sp? July 6 (Kincaid).

- Lispa albitarsis** Stein? Spanish Point, July 5 (Spaeth). A female agrees with this species except that the palpi are blackish.
- Fucillia marina** Macquart (*F. fucorum* of authors, not Fallen). In great number on piles of sea-weed, March 6 (F. M. Jones).

## SCATOPHAGIDÆ.

**Scatophaga** sp? Recorded.

## BORBORIDÆ.

- Leptocera fontinalis** Fallen, (*Limosina fontinalis*). July 2 (Kincaid).
- Leptocera venalicia** Osten Sacken. May 3 (F. M. Jones). Supposed to have been introduced into Cuba by the slave trade.
- Leptocera illota** Williston. Spanish Point, July 5 (Spaeth).
- Leptocera** sp. Three specimens of a smaller species from a pile of seaweed, February 4 and March 6 (F. M. Jones). The specimens are imperfect.

**Borborus minutus** sp. nov.

Male: Front covered with light brownish pollen, two dark brown stripes extending upward from the base of the antennæ and over the vertex, the stripes bearing a narrow whitish line above the antennæ, face brown, cheeks whitish pollinose, antennæ black. Thorax light brownish pollinose with three dark brown stripes, the middle one double the width of the others, scutellum light brown, the disc and apex slightly darker, pleura brownish pollinose. Abdomen dull grayish black. Legs black, the posterior metatarsis about double the width of the following joint. Halteres yellow. Wings grayish hyaline, veins dark brown. Length 2mm.

Holotype, Spanish Point, July 5 (Spaeth), in the author's collection. Two paratypes, Horse Neck Beach, Mass., July 8, 1896, in the collection of the Boston Society of Natural History. The latter were collected by Dr. Garry de N. Hough, and were in my collection for a number of years. I have adopted a manuscript name proposed by Dr. Hough.

## SCIOMYZIDÆ.

**Tetanocera kincaidi** sp. nov.

Male: Face and inferior orbits white, with a brown stripe on the cheek extending from the eye to the oral margin; front yellow, the frontal vitta and a transverse stripe extending from the base of the antennæ to the orbits brown, frontal orbits narrow, white; antennæ yellow, the bristles and hairs on the second joint and the arista black. Thorax yellow, with two narrow dorsal lines and broad lateral stripes of brown; pleura light yellow with a broad brown stripe; scutellum yellow with four black marginal bristles. Abdomen brown, lateral margins and the genitalia yellow. Halteres light yellow. Legs yellow, a spot on the under side of the middle and posterior femora somewhat beyond the middle, tips of the tibiæ and the tarsi blackish, due in part to the blackish hairs, middle coxæ with a tuft of black bristles below, front of the anterior coxæ bearing three bristles. Wings similar to *T. spinicornis* Loew, but proportionately broader and the reticulations less profuse, with five unequally arranged square hyaline spots in the marginal cell beyond the end of the first vein. Length, 5mm.

Female: Similar to the male, but with an obsolete dorsal line on the abdomen. Length 6mm.

Ten Specimens. Holotype, July 29, allotype June 26, 1905 (Kincaid) and three paratypes, May 30 (Mowbray); January 12 and February 5 (F. M. Jones) in the author's collection. Paratypes also in the Museum of Comparative Zoology, and in the Collections American Entomological Society.

With only two poor specimens before me this was referred to *T. spinicornis* in my previous list. It closely resembles that species but can be readily separated by the wings as described above, the single, not double spots on the under side of the posterior femora and the larger and less acute third joint of the antennæ. It is also slightly larger.

The species also resembles *T. setosa* Coq. but the spots on the under side of the posterior femora and the five unequally arranged hyaline spots in the marginal cell beyond the end of the first longitudinal vein distinguish it from that species.

**Tetanocera (Dictya) umbrarum** Linné (*T. pictipes* Loew, Monog. N. Amer. Diptera, I, 111, 1862). Two specimens, March 20 (F. M. Jones); July 15 (Kincaid).

#### SAPROMYZIDÆ.

**Sapromyza saroria** Williston. July 6 and 11 (Kincaid); Jan 6, April 10 and May 4 "On the under side of palmetto leaves in a swamp." (F. M. Jones).

#### ORTALIDÆ.

**Euxesta abdominalis** Loew. June 30 (Kincaid). Sweep net, Warwick Marshes, December 11, also March 5 (F. M. Jones).

**Euxesta annonae** Fabricius. June 26 (Kincaid).

**Euxesta pusio** Loew. June 26 (Kincaid).

**Chaetopsis fulvifrons** Macquart (*Urophora fulvifrons* Macq. Dipt. Exot., Suppl. V, 125, pl. VII, fig. 8, 1855). July 29 and 30 (Kincaid); March 20 (F. M. Jones). This is probably the same as the *C. aenea* of my previous list, as recorded by J. Matthew Jones in 1876. It differs from the true *C. aenea* in lacking the frontal cross-bristles and in having only three or four frontal orbital bristles.

**Chætopsis debilis** Loew. Spanish Point, July 5 (Spaeth). This may prove to be only a variety of *C. fulvifrons* Macq. as the color of the basal segments of the abdomen and the bands on the wings, are both apparently variable characters.

**Ceratitis capitata** Wied. "Fruit fly."

This fly which was introduced sometime prior to 1870 is still on the Islands but in very limited numbers owing to the vigorous campaign that has been waged against it. The authorities deserved great credit for their perseverance in endeavoring to exterminate this insect and we hope that in the near future they may again be able to resume the raising of the various fruits affected. There is little doubt that this vigorous action has for many years checked the western movement of this great fruit pest.

Having written to Mr. F. M. Jones in May, 1909, to ascertain if the fruit fly was still on the Islands, he replied: "In regard to the fruit fly (*Ceratites*); several years ago a regular crusade against this insect was undertaken and is being continued. All of the Surinam cherry trees were cut down, also most of the sweet orange trees and peach trees. Inspectors were appointed in each parish and authorized to visit every tree and strip off the unripe fruit,—oranges, lemons, sapadillas, loquats, sugar-apples, etc.; pawpaws were ordered to be gathered before turning yellow, under the penalty of having the trees chopped down. All this was in an effort to entirely exterminate the insect, it has undoubtedly greatly reduced its numbers for I failed to find a specimen, though I searched all kind of fruits where I could find any which had escaped inspectors. I heard of the fly as still present this spring. The crusade has not the support of the people and trees are concealed from the inspectors when possible, so that probably when the vigilance is relaxed the insect will appear again. There are several wild fruits which should be examined as possible breeding places. Sorry I could not get you some specimens."

Expressing to my friend Dr. R. A. Spaeth a desire to obtain some specimens of the "fruit fly" he spoke to Col. W. R. Winter who bred some specimens which I received through the kindness of Professor E. L. Mark. The letter accompanying the specimens contains so much of interest pertaining to the habits of the fly that I have taken the liberty of publishing it in part.

"With reference to the experiments, several punctured peaches placed in isolation cages, developed flies in from seven to ten days from the time in which the larvæ entered the soil, as I had not the actual date of the depositing of the eggs, I did not trouble to keep an exact record beyond noting the dates of the larvæ leaving the fruit and the appearance of the fly."

"Two peaches in perfect condition were left on an exposed branch of the tree and watched, but owing to the scarcity of flies it was not until 4 P. M. on the 13th of July that a fly appeared and punctured one of them; after ten minutes I killed the fly. The peach was carefully examined and one puncture only was found. On the 17th the fruit was found to be soft around the puncture and was gathered. It was placed in a gauze covered glass jar on two and a half inches of clear, dry sand. On the 24th at 10 A. M. the maggots were observed going into the sand, many of them being visible through the sides of the glass, they having gone down between the sand and the glass. On the 27th the peach was removed and examined. Two dead maggots were found in it. The pupæ were carefully separated from the sand and twelve more were found, these were placed in dry soil in an isolation cage made especially for this experiment. The flies appeared as follows: two on the 1st of August at 7 and 10 A. M. Three on the 2nd, before 4 P. M. Two on the 3rd, before 7 P. M., and on the 4th, before 9 A. M. Carried no further as all flies fed on arsenate of lead which was placed in the cage and were found dead on the 5th at 7 A. M. Weather very hot and dry, no rain, temperature averaging 82°.

**Aciura insecta** Loew. June 26 (Kincaid); Spanish Point, July 5th (Spaeth).

**Ensina picciola** Bigot, (*Trypeta humilis* Loew). Abundant in sweep-net, December 8 and 29 and May 17 (F. M. Jones). Road from Hamilton to Grasmere June 26 and Spanish Point July 5 (Spaeth).

## SEPSIDÆ.

**Sepsis violacea** Meigen. "Common January 21 and April 29 (F. M. Jones); June 30 and July 29 (Kincaid); Spanish Point, July 5 (Spaeth).

**Piophilha casei** Linné. The cheese fly. Recorded by Prof. Verrill.

## EPHYDRIDÆ.

**Mosillus nana** Walker? (*Ephydra nana* Walker, Trans. Ent. Soc., London, N. Ser. IV, 234, 1857). July 30 (Kincaid); Spanish Point, July 5 (Spaeth).

**Ephydra austrina** Coquillett. One specimen collected by C. A. Davis.

## OSCIDINIDÆ.

**Hippelates plebeius** Loew. June 28 and 30 (Kincaid); Agar's Island, June 18 (Spaeth).

**Hippelates pusio** Loew. July 12 (Kincaid).

**Oscinis coxendix** Fitch. Common. June 30 and July 12-18 (Kincaid); February 4 (F. M. Jones); near Hamilton, June 26 and Spanish Point, July 5 (Spaeth).

**Oscinis trigramma** Loew. July 11, 15 and 26 (Kincaid).

**Oscinis umbrosa** Loew. Common, June 25 to July 29 (Kincaid).

## DROSOPHILIDÆ.

**Drosophila adusta** Loew. July 25, 29 (Kincaid); February 4 (F. M. Jones).

**Drosophila ampelophila** Loew. January 7 (F. M. Jones).

**Drosophila repleta** Wollaston, (*D. punctulata* Loew, Berl. Ent. Zeits., VI, 232, 1862; *D. adspersa* Mik, Wien. Ent. Zeitzg. V. 328, 1886.) January 1 and May 6 (F. M. Jones).

**Paratissa pollinosa** Williston, July 10 (Kincaid); December 24 and March 6, on sea-weed (F. M. Jones).

## AGROMYZIDÆ.

**Phytomyza** sp. January 27, February 24 (F. M. Jones).

**Agromyza æneiventris** Fallen. July 1 (Kincaid).

**Agromyza pusilla** Meigen. July 5 (Kincaid).

**Agromyza maculosa** Malloch. May 17 (F. M. Jones).

**Desmometopa m-nigrum** Zetterstedt, May 9 (F. M. Jones).

**Milichiella lacteipennis** Loew, (*Ophthalmomyia lacteipennis*). July 6, 12 and 28 (Kincaid); Spanish Point, July 5 (Spaeth).

## BIBLIOGRAPHY OF THE WORKS PERTAINING TO THE DIPTERA OF BERMUDA.

1859. The Naturalist in Bermuda by J. Matthew Jones, page 123.

1876. Visitors' Guide to Bermuda by J. Matthew Jones, page 143.

1889. Observations on the Insects of Bermuda by Dr. P. R. Uhler; In the Bermuda Islands, by Angelo Heilprin, pages 152-158.

1892. Land Fauna of the Bermuda, by Dr. Fred Dahl, Plankton Expedition, vol. 1, A, page 109.

1901-02. The Bermuda Islands, by Prof. A. E. Verrill, Trans. Connecticut Acad. Arts and Science, vol. XI, pages 740-749.

1904. A Revised List of the Diptera of Bermuda, by Charles W. Johnson, Psyche, vol. XI, pages 76-80.



THE TAXONOMIC VALUE OF THE CHARACTERS OF THE MALE  
GENITAL ARMATURE IN THE GENUS  
TETRANYCHUS DUFOUR.

By H. E. EWING.  
Oregon Agricultural College, Corvallis, Or.

INTRODUCTION.

The red spiders of the genus *Tetranychus* Dufour have always offered a knotty problem for systematists working in the order Acarina. When these mites were first noticed they were found on such a multitude of host plants, and showed such a great variation in color that the early workers considered the genus as being made up of a great many species or varieties. Later it was found that certain well known forms could have a great variety of hosts, also that there was a considerable variation in size and color among individuals on a single host plant. Then there was a tendency to lump the forms together into a very few species, although confusion as to synonymy still remained. In 1877 Professor A. T. Tozzetti called attention to the systematic value of the characters of the mouth-parts and of the tarsal appendages. Later Professor A. Berlese made use of some very important characters, the variations of the specialized setae on the palpal thumb. In 1900 Mr. N. Banks in his, "Red spiders of the United States," showed that the characters used by both of these authors were of special value in helping to separate our American forms. It is to Mr. Banks that we should give the credit for first straightening out many of the synonymous and wrongly determined species found in our country. But as yet, both in this country and in Europe, there is much confusion in regard to the identity and synonymy of some of our best known and most injurious species.

After examining hundreds of specimens from many parts of the United States, with magnifications up to 2000 diameters, and using an oil emersion lens, the present writer has found that the genital armature of the male is excellently adapted for systematic purposes.

The genital armature of the male may be considered as being composed of the penis, its attachments, and the slit-like opening through which it is protruded. For our purposes the penis alone

will be considered, as it is well chitinized, quite visible, and offers great variations among different species, while only a few exist among individuals of a single species taken from the same host plant.

GENERAL STRUCTURE OF THE PENIS AND EXPLANATION OF TERMS USED IN REFERENCE TO ITS PARTS. (See Figure.)

*Inner lobe*—The imbedded or attached part of the penis. It is much less chitinized than the penis proper.

*Shaft*—The free part of the penis. It is much more strongly chitinized than the inner lobe.

*Basilar lobe*—The enlarged proximal part of the shaft. It is not always present.

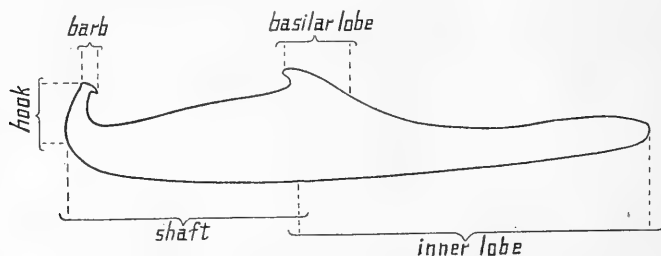

FIG. 1. Penis of male of *Tetranychus telarius* Linn., as seen from the right side, X 1800; showing the various parts delineated and labeled.

*Hook*—The dorsally curved distal part of the penis. It is frequently absent.

*Barb*—The flattened or knobbed or bent tip of the penis.

KEY TO THE MALES THUS FAR EXAMINED.

- I. 1. Penis long, tapering, without hook.
  - II. 1. Penis without basilar lobe; long, seta or spine-like.
    - III. 1. Shaft less than 0.04 mm. in length, frequently doubly curved..... *T. weldoni* n. sp.
    - III. 2. Shaft over 0.06 mm. in length, with but a single curve..... *T. longipes* Banks.
  - II. 2. Penis with swollen part at the base of the shaft (basilar lobe).
    - III. 1. Shaft strongly curved; without barb. *T. flavus* n. sp.
    - III. 2. Shaft less curved; with flattened barb..... *T. borealis* n. sp.
- I. 2. Penis short, stouter, with hook.
  - II. 1. Hook without barb.
    - III. 1. Hook bent at an angle of from 30° to 50° to the axis of shaft..... *T. mytilaspidis* Riley
    - III. 2. Hook bent at an angle equal to at least 90° to axis of shaft..... *T. pratensis* Banks
  - II. 2. Hook with prominent, flattened, recurved barb..... *T. telarius* Linn.

## NOTES ON OLD SPECIES AND DESCRIPTIONS OF NEW ONES.

In these notes three new species are for the first time here delineated. Before long the writer hopes to publish complete descriptions of these together with illustrations of those structures having special systematic importance.

***Tetranychus telarius* Linn.**

*Acarus telarius* Linn.—Fn. Suec., 481, No. 1974 (1761).

This species appears to have the following American synonyms:

*Tetranychus sexmaculatus* Riley (?)—Insect Life, Vol. II., p. 225. (1890).

*Tetranychus 2-maculatus* Harvey—Ann. Rep't. Maine Agri. Exp. Sta., part IV., p. 133, Pl. III. (1892).

*Tetranychus gloveri* Banks—The Red Spider of the United States. Tech. Ser. No. 8, Div. Entom., U. S. Dep't. Agri., p. 76. (1900).

This is our most common and most widely distributed species of red spider. It is also the most common species found in Europe. I give the following description of the penis of the male:

Penis short, stout. Inner lobe long, rod-like; longer than the shaft, and somewhat bent. Shaft thick, stout, short, much stouter at its base than at its distal end where it bears the prominent hook. Basilar lobe present, on the upper side of the shaft; it is small, protrudes slightly, and is hook-like in shape. Hook short, stout, extending dorsally; three or four times as broad at its base as it is at its apex; it forms an angle of over 90° with the apex of the shaft. Barb present at the end of the hook, flattened and recurved.

That our well known *T. 2-maculatus* Harvey is synonymous with *T. telarius* Linn. there can be but little doubt. I have sent specimens to Professor A. Berlese, of Italy, and after comparing them with the European species, he writes that they are the same. I have sent specimens to Dr. A. C. Oudemans, of Netherlands, and he states that they equal *T. telarius* L. I have received named female specimens of European individuals of *T. telarius* Linn. from Dr. Oudemans, which were collected from English elm (*Ulmus campestris* L.) at Amsterdam, October 1910. I have compared these females with the females of our *T. bimaculatus* Linn. I find in these specimens the presence of the same six bristles near the base of the tarsal pedicel of leg I. The four tenent hairs are similarly arranged and shaped in every respect as they are in our species. The tarsal pedicel is similar to our species. The tarsal claw is six cleft, and exactly like those I have examined in America.

In the case of the palpal characters I find the same claw, thumb, finger, and sense hair; and each with the same form, relative size, and position as in our species. The thumb also bears the same three bristles; and one of the terminal spines is present. I find difficulty in getting a specimen in the right attitude to show both of the terminal spines properly.

The females show the structures of the genital and anal areas to be the same as in our species. The plate in front of the vulva is the same, and has the common two bristles. The anal papilla is the same as in our species, and is flanked on each side by two bristles as in our species. These bristles are of the same size, and are situated as in our species.

In this country Mr. Banks and others have recognized a form which has passed under the name of *T. telarius* Linn. I have compared our American forms of *T. telarius* Linn. with our *T. bimaculatus* Harvey, and I will state that after examining hundreds of specimens of both supposedly distinct species from many States (East, West and Middle) in this country, I can find no structural difference between the two. Mr. Banks, in his "Red Spiders of the United States," represents the thumb of the palpus of *T. bimaculatus* Harvey as bearing but one distal digit, a long seta, and a basilar spine; the thumb of *T. telarius* Linn. as bearing three distal digits, two small setae, and no basilar spine. By means of treatment with chloral hydrate solution or other clearing agencies, and by use of magnifications of over 2000 diameters, I find that there are more appendages to the thumb in both cases than Banks has represented. I find in both cases that the palpal thumb bears a large stout digit at its tip, above this two small, diverging spines or digits. Near the base in both cases is the spine which Banks has figured for *T. bimaculatus* Harvey. Toward the tip of the thumb and below the big finger is a large, curved seta also shown in Banks' figure of *T. bimaculatus* Harvey. Behind the basilar spine I find in all instances two more prominent bristles not figured in either Bank's drawing of *T. bimaculatus* Harvey or his drawing of *T. telarius* Linn.! Also I find that the tarsal claw in both cases is six-cleft instead of being four cleft as stated in Bank's paper!

There are some other points which I should like to mention in regard to the synonymy of these two species, but for the present I shall stop with these.

*Tetranychus sexmaculatus* Riley may be the same as *T. telarius* Linn. I have received many specimens of this species, sent by Professor H. J. Quayle, from Southern California. I find that the females agree with the females of *T. telarius* Linn. in every minute detail of structure. I have transferred live individuals to the common host plants of *T. telarius* Linn. Here they have not thrived successfully. In most cases they would not establish themselves. Unfortunately I have never examined a male of *T. sexmaculatus* Riley, and since so much depends upon the characters of the male genital armature we cannot be sure of the synonymy of the two species until a male specimen is examined.

*Tetranychus gloveri* Banks appears to be the same as *T. telarius* Linn. I have received scores of individuals of *T. gloveri* Banks, on cotton, from Georgia, sent by E. L. Worsham. These agree in all respects with my specimens of *T. telarius* Linn. collected from many places in the United States, and with the specimens of *T. telarius* Linn. received from Europe. Professor A. Berlese has examined specimens of *T. gloveri* Banks from cotton, and has considered it as being the same as *T. telarius* Linn.

***Tetranychus weldoni* n. sp.**

I have received many specimens of red spiders from G. P. Weldon labeled *T. bimaculatus* Harvey. For a long time I have considered that they were this species, which is, as I have shown, a synonym of *T. telarius* Linn. Recently I have found that the male is different from the male of the *T. telarius* Linn.

Female: Similar in all respects to the female of *T. telarius* Linn.

Male: Different from male of *T. telarius* L. in characters of penis and spur on palpus. Spur on palpus not so pointed as in *T. telarius* Linn. Penis very long, rod-like; equal to a third the length of the body. Inner lobe short, rod-like, slightly swollen at its anterior end. Shaft, rod-like, not setiform; gradually tapering as you pass backward; posterior one half turned upward; tip narrowly rounded, not pointed. Basilar lobe absent. Hook absent. Barb absent.

From Grand Junction, Colorado; on apple, prune, and cotton wood; by G. P. Weldon.

***Tetranychus borealis* n. sp.**

Female: Similar to the female of *T. telarius* Linn. but smaller, and never orange or red. The inner prongs of the tarsal claw are stouter than the inner prongs of the tarsal claw of *T. telarius* Linn.

Male: Similar to the male of *T. telarius* Linn., except for the penis. Penis long, straight. Inner lobe about equal to basilar lobe in length. Shaft shaped like a slender rod. Basilar lobe very pronounced, cone-shaped, equal to about one fourth the length of the shaft. Hook absent. Barb knob-like.

From Coast Range Mountains, Benton Co., Oregon; on *Spirea* sp.; by the writer.

This form is very closely related to another species, the description of which follows.

***Tetranychus flavus* n. sp.**

For over a year I have been studying a form of red spider which is a serious orchard pest in Oregon. It especially is injurious to apples when they are growing above an elevation of 1000 feet above sea level. In Hood River Valley I have found this form so serious as to discolor the leaves of whole orchards of apples, and in some instances as to cause defoliation late in the summer. When fall comes and the trees drop their leaves, these mites all become a pale yellow in color and collect in masses about the trunks of trees and the cracks of the ground for a region of several feet from the tree bases. Here they pass the winter, and become active again in the spring when the trees put out their foliage. At first I considered this species as but a form of our common *T. telarius* L. After studying these two forms for two seasons in the laboratory, I find that they must be considered as distinct species. This species is even more closely related to the one just described, *T. borealis* n. sp. It may be described as follows:

General appearance similar to *T. borealis* n. sp.; also similar to *T. telarius* Linn., but the individuals are smaller. Color of immature forms green or yellow; of adults green or yellow, with black markings not pronounced. Adults are never orange or red. In the winter when deprived of food supply all instars yellow. General structures similar to those of *T. telarius* Linn., but the tarsal claw in most instances is only five-cleft, the two inner prongs being united. In *T. telarius* Linn., the tarsal claw is, I find, six-cleft; however, it has been represented by others as being four-cleft. In the case of the female of *T. flavus* the anal spines are situated farther forward than in *T. telarius* Linn., and also nearer the margins of the genital slit or opening. This species differs from *T. borealis* n. sp. in the tarsal characters which are nearer those of *T. telarius* Linn., and in having no barb to the penis.

The penis of this species is entirely different from the penis of *T. telarius* Linn. It is long and spine-like. In length it is equal to a third or fourth of the entire length of the body. Inner lobe of penis not prom-

inent, slightly swollen at its anterior end; in size, smaller than the basilar lobe of shaft. Shaft long, curved, and resembling the sting of a wasp; varying greatly in curvature, generally bending downward, then upward, or it may have but a single curve, or it might be straight. Basilar lobe, large, subcylindrical, equal to over one fourth of the total length of the entire shaft. Hook and barb absent.

Generally distributed over Hood River Valley, Oregon; on apple trees especially; observed and reported by many people. Found in some places in the Willamette Valley, Oregon; on apples; by the writer. Probably present throughout the Pacific Northwest above altitudes of 1000 feet.

#### ***Tetranychus pratensis* Banks.**

*Tetranychus pratensis* Banks—Proc. Entom. Soc. Wash., Vol. XIV, p. 97. (1912).

I have examined specimens of this species, and find that the tarsal appendages are very peculiar. I find that there are two claws as stated by Banks, but only one, the outer, is simple. The inner claw is bent downward very near its base, and beyond this bend it is three cleft. On each side of the tarsal claws is a short projection from which extends a pair of tenent hairs. The penis of the male may be described as follows:

Inner lobe slightly over one half as long as the shaft of the penis. Shaft stout, somewhat similar to the shaft in *T. telarius* Linn.; enlarged slightly at its base so as to form the basilar lobe. Hook pronounced; bent at an angle of about 90° to the axis of the shaft. Barb absent.

From Pullman, Washington; on timothy; by G. R. Hyslop.

#### ***Tetranychus mytilaspidis* Riley.**

*Penthalodes mytilaspidis* Riley—Hubbard, Orange Insects, p. 216. (1885).

This very characteristic red spider differs from most of our species in having the bristles of the body arising from prominent tubercles. In many respects it is about as far removed from *T. telarius* Linn. as any of the species of the genus. In the characteristics of the male genital armature it appears to be rather closely related to *T. telarius* Linn. The penis may be described as follows:

Inner lobe about one and a half times as long as the penis proper; not swollen at its anterior end. Shaft very short, and stout. A basilar lobe present in the form of a stout, more or less hook-like, protuberance on the dorsal side of the shaft. In this respect the penis is like that of *T. telarius* Linn. Hook very large, stout; bent at an angle of from 30° to 50° degrees to the axis of the shaft. Barb absent, but the distal part of the hook is bent out considerably.

Generally distributed in Southern California on citrus trees, also found on deciduous trees. A serious pest of stone and pomaceous fruit trees in certain parts of Oregon.

***Tetranychus longipes* Banks.**

*Tetranychus longipes* Banks—Proc. Entom. Soc. Wash., Vol. XIV., p. 27. (1912).

This species is so different from most of the other species in the genus, that it might well be made the type of a new genus. It has strong affinities with the genus *Bryobia*; in the general shape of the body, in the length of the anterior pair of legs, in the possession of the horn-like setae at the anterior end of the cephalothorax. I have examined the tarsal appendages of leg I, and find that with 2000 diameters magnification they are very complicated, and do not consist of two simple claws as Banks states. There is one large simple claw to the tarsus. Above this and apparently fused with it is a chitinous projection with many parallel hairs forming a comb. On either side of the tarsal claw is a pulvillus-like structure, each of which has several projecting tenent or other hairs.

I have observed but one male specimen of this species, and this specimen was very much dilapidated. What I have taken to be the penis may be described as follows:

Penis very large and long; much longer than the penis of any other species examined. Inner lobe about one third as long as the shaft, broadest at its base. Shaft long, curved, seta-like. Basilar lobe, hook, and barb absent.

From Springer, New Mexico; on grass (*Agropyron*); by C. N. Ainslie. From Holtville, California; by Wildermuth.



X  
A SYNOPSIS OF THE DESCRIBED NORTH AMERICAN SPECIES  
OF THE DIPTEROUS GENUS TIPULA L.

By W. G. DIETZ, M. D.

The following synopsis is not offered to fill the proverbial long felt want, but rather that it may facilitate and lessen the labor of the student who undertakes the study of the above mentioned genus. It is based almost entirely on the original descriptions with the exception of those of Fabricius, and for these I have had to depend upon those of Wiedemann.\*

Many of these fall short of completeness. Some, like those of Walker's, as was his custom elsewhere, are woefully defective. Fortunately not a few of these have been authentically recognized and wherever such was the case and representative material was at hand, I have drawn upon this source of information. It will readily be seen that this synopsis is not merely a synoptical table in the usual sense and hence, some explanatory remarks are deemed necessary. To give more certitude to the identification of a given species, the usual differential diagnosis is followed by a short detail description. In the latter, especial stress has been laid upon the structure and formation of the hypopygium—ninth segment—and the eighth abdominal segment of the male, though in many instances no information on these points was available. All references to the apical appendages of the male hypopygium have been omitted, important and almost absolute their consideration becomes in the separation of otherwise very closely allied or similar forms, as this would have led far beyond the scope of this paper. It must be remembered that all references to the eighth and ninth—hypopygium—abdominal segments refer to the male, unless otherwise stated.†

In the use of the synopsis, a certain margin must be allowed for the interpretation of terms used. I have, as nearly as possible made use of the identical language of the authors in their descriptions and in the translations from the Latin have kept close to the sense of the writer. What to one observer might

\* Aussereuropäische zwei flügelige Insecten. Vol. I.

† The term "ninth tergite" and "ninth sternite" in the text are the equivalents of "upper and lower lamella," respectively, used by writers.

appear as a fascia, might merely be looked upon as a spot by another and vice versa. Under the heading, "Wings Spotted," species may have been included which might with equal propriety have been placed under "wings unicolorous" and the reverse. Whenever I have been conscious of such being the case, I have endeavored to remedy the difficulty by cross-references. To those who expect this synopsis to be an easy road to the goal, disappointment will come. To determine the relative position of a given form and then by close study of the original description and whenever possible, of the type, the student should be enabled with certain limitations, to determine whether a given form is described or not. To the critic this paper will furnish a rich field, more so perhaps, than the time and labor bestowed upon it should warrant.

Following the synopsis, I have added a list with habitat and bibliography of these species not contained in Prof. Aldrich's catalogue.

- |    |  |                       |
|----|--|-----------------------|
| 1. | Wings normal in size in both sexes.....  | 2                     |
|    | Wings reduced in size, or vestigial, at least in the female.....   | 165                   |
| 2. | Wings spotted or striped.....  | 3                     |
|    | Wings unicolorous; at most, costal margin and stigma fuscous, or a white, hyaline spot before the stigma, more rarely another behind it; veins may be margined with fuscous.....   | 87*                   |
| 3. | Wings spotted, marbled or clouded.....   | 4                     |
|    | Not as above, but the costal margin, fifth longitudinal vein and posterior cross-vein more or less broadly margined with fuscous, apex of wing frequently infuscate; generally a pale hyaline vitta in the second basal cell.....  | 79                    |
| 4. | With pale transverse fascia.....   | 5                     |
|    | Without such a fascia.....   | 24                    |
| 5. | Wings conspicuously variegated with dark fuscous.....  | 6                     |
|    | Wings not, or inconspicuously variegated with fuscous.....   | 15                    |
| 6. | Fascia behind the stigma.....  | 7                     |
|    | Fascia before the stigma.....  | 10                    |
| 7. | Fascia angulate.....   | 8                     |
|    | Fascia not angulate.....   | 9                     |
| 8. | Joints of flagellum bicolorous. Yellow, thoracic vittæ gray; abdomen with dorsal stripe, ninth tergite narrowly emarginate in the middle; with two, rather sharp teeth from the middle of the posterior margin, lateral angles produced; ninth sternite very deeply and broadly divided; pleural plates distinct. Length 12-13mm. Eight sternite entire.....                                     | <i>angulata</i> Loew  |
|    | Joints of flagellum unicolorous. Mesonotum with about six fuscous, somewhat irregular lines, the middle pair more widely separated anteriorly; abdomen trivittate; eight sternite entire; hypopygium medium-sized, ninth tergite with rather broad V-shaped emargination, its margin with several teeth; ninth sternite with V-shaped emargination; pleural plates distinct. Length 14-23 mm.... | <i>trivittata</i> Say |

\*There may be an indistinct fuscous spot over the origin of the praeurca. The whitish spot before the stigma is called ante-stigmal spot, in the text.

9. Fascia does not extend beyond the fourth posterior cell; joints of flagellum bicolorous. Brown; three mesonotal stripes, margined with darker brown; abdomen trivittate; posterior margin of ninth tergite with two triangular projections, between which is a deep, narrow U-shaped incision; ninth sternite with deep V-shaped incision; pleural suture distinct. Length 14-19 mm..... *aspersa* Doane  
Fascia reaches the posterior wing margin; joints of flagellum fuscous. Brown; antennæ long; mesonotal vittæ very broad; abdomen trivittate posterior margin of segments yellowish; hypopygium small, ninth tergite with a small, ninth sternite with deep and rather broad incision. Length 12 mm. (♂)..... *decora* Doane
10. Fascia V-shaped, broken; joints of flagellum not bicolorous. Brownish-yellow, mesonotal vittæ broad. Abdomen spotted, trivittate; ninth tergite tumid, posterior margin with broad crescent-shaped incision, in the middle of which is a small semi-circular incision; posterior margin of ninth sternite bearing a pair of leaf like appendages. Length 20 mm. (♂)..... *albimacula* Doane  
Fascia not distinctly angulate..... 11
11. Joints of flagellum unicolorous; thoracic vittæ not margined..... 12  
Joints of flagellum bicolorous; thoracic vittæ margined; posterior cells 1-3 infusate. Dark-yellowish; mesonotal vittæ broad; abdomen conspicuously trivittate. Length 14 mm. (♀)..... *fuliginosa* Say
12. Posterior cells 1-3 more or less white. Gray; mesonotal vittæ broad; abdomen with three stripes; ninth tergite with median impression and slight incision; posterior margin of ninth sternite with a broad, blunt triangular process; pleural suture present. Length 17 mm.....  
*vittatapennis* Doane  
*albovittata* Doane sgn. .... 13
13. Posterior cells 1-3 not white..... 13  
Posterior margin of abdominal segments not paler. Brown; metanotum with three gray lines, margined with fuscous. Abdomen with dorsal stripe; ninth tergite with deep, broad V-shaped incision; ninth sternite with deep, very narrow incision. No pleural suture. Length 11 mm. (♂)..... *cylindrata* Doane  
Posterior margin of abdominal segments paler..... 14
14. A white spot in middle of first basal cell. Yellowish; mesonotum with four brown stripes. Abdomen trivittate; eight sternite produced and narrowed behind, with shallow, rounded incision; hypopygium large, ninth tergite with a slight depression and two very small points; ninth sternite with shallow, rounded incision containing a pair of processes; nearly all the veins bordered with whitish. Length 17 mm...  
*spectabilis* Doane  
First basal cell without a white spot. Brown; mesonotum gray with five brown stripes; abdomen trivittate; ninth tergite with deep median furrow, posterior margin with small V-shaped incision; ninth sternite with broad deep incision containing two tumid processes. Length 18-25 mm..... *incisa* Doane
15. Apex of wings blackish; a broad whitish, subapical fascia. Yellow, thorax trivittate; abdomen with dorsal line and indistinct lateral lines. Length 15 mm. (♀)..... *apicalis* Loew  
Apex of wings not blackish..... 16
16. Joints of flagellum bicolorous. Median vitta of thorax obsolete, lateral vittæ very distinct, fuscous; abdomen pale, last two segments and posterior margin of the remaining ones, dark fuscous; hypopygium large, ninth tergite prolonged posteriorly into a median, laterally compressed, bladelike process; ninth sternite with broad V-shaped incision, prolonged anteriorly into a narrow slit, from the base of which project two long setæ. Length 9-12 mm..... *fasciata* Loew  
Joints of flagellum unicolorous..... 17
17. Antennæ wholly fuscous..... 18  
Antennæ not wholly fuscous..... 19

18. Origin of praefurca fuscous; mesonotum with six brown stripes, median pair broad, conspicuous. Brown; lateral and posterior margin of abdominal segments paler; eight sternite with median, short, two lobed appendage; hypopygium small, elongate, ninth tergite with deep V-shaped incision; ninth sternite narrowly divided in almost its entire length. Length 11 mm. (♂).....*tristis* Doane  
 Origin of praefurca not fuscous; mesonotum with three dark stripes, each of which is divided by a light brown line. Brown; lateral margin of abdominal segments broadly, posterior narrowly paler; ninth tergite with deep, narrow V-shaped incision; no pleural suture. Length 13 mm. (♂).....*marina* Doane
19. A fuscous spot at beginning of praefurca.....20  
 Without such a spot.....22
20. Wings brownish, darker towards the apex, a faint spot in first basal cell, a whitish spot in posterior margin of axillary cell. Yellow; mesonotum with four stripes; abdomen trivittate, lateral stripes faint; eight sternite produced and narrowed posteriorly; hypopygium large, ninth tergite produced into two long, somewhat flattened triangular processes; ninth sternite with lateral appendages and posterior margin with two small median ones. Length 17 mm. (♂) *armata* \*Doane  
 Wings not so marked.....21
21. Yellow, a whitish spot beyond the stigma. Mesonotal vittæ more or less distinct; eight sternite semicircularly incised; ninth tergite divided by a median suture into two subrectangular processes; ninth sternite large, with downward projecting spatulate processes. Length 13 mm. (♂). 12 mm. (♀).....*derbyi* †Doane  
 Brownish yellow, no white spot beyond the stigma. Thorax with three brown stripes; abdomen with three distinct brown stripes, posterior margin of segments whitish; eight sternite with rounded incision of the posterior margin, lateral angles with triangular, hooked appendages; ninth tergite with broad, deep V-shaped incision; posterior margin of ninth sternite with broad U-shaped incision, containing a pair of tumid appendages. Length 15 mm. (♂).....*occidentalis* Doane
22. All posterior cells more or less white. Light brown; mesonotum with four rather broad vittæ; abdomen with broad dorsal vitta; eight sternite narrowed posteriorly, emarginate at apex; ninth tergite small with deep V-shaped incision and narrow median depression; ninth sternite almost divided by a deep, U-shaped incision, containing a pair of tumid appendages. Length 11 mm. (♂).....*acutipleura* Doane  
 Some or all posterior cells not tinged with white.....23
23. Gray, fourth posterior cell except its apex, occupied by a fascia-like spot, † first posterior cell with a spot in the middle and extreme apex white. Thorax whitish, vittæ slightly darker, not margined; abdomen trivittate. Length 14 mm.....*subfasciata* Loew  
 Brown, posterior cells not white; the white fascia extends from before the stigma through outer parts of basal cells to the posterior margin. Mesonotum quadrivittate; anterior margin of abdominal segments darker brown; ninth tergite short, broad, with inconspicuous median ridge, posterior margin slightly emarginate, lateral angles ending in short, downward projecting processes; ninth sternite with broad, rounded incision, lateral angles with two lobed appendages. Length 10 mm. (♂).....*incurva* Doane

\*see also 60.

†Would perhaps more properly be placed under species: "wings unicolorous, a large white spot before the stigma."

‡This spot can hardly be called a fascia.

24. Wings marked with pale and fuscous spots, or the latter only.....25\*  
 Wings marked with pale spots only.....65
25. A spot at base of basal cells.....26  
 Without such a spot.....34
26. Thoracic vittæ margined with fuscous.....27  
 Thoracic vittæ not margined.....33
27. Joints of flagellum bicolorous; abdomen of female very much elongated.  
 Abdomen with lateral stripes; hypopygium small, ninth tergite short,  
 rather broadly emarginate, ninth sternite more narrowly emarginate.  
 Length 15½ mm. (♂). 19-20 mm. (♀).....*langiventris* Loew  
 Joints of flagellum unicolorous.....28
28. Color cinereous.....29  
 Color brown.....32
29. Entire wing with dark fuscous and white spots.....30  
 Not so marked.....31
30. Fourth posterior cell almost entirely white; ovipositor serrulate ben-  
 neath; abdominal stripes indistinct. Length 23-24 mm.....*tesselata* Loew  
 First and fourth posterior cells white at base only. Abdomen with  
 fuscous dorsal vitta and lateral lines; hypopygium small; ninth tergite  
 small. Length 17 mm.....*septentrionalis* Loew
31. Basal joints of antennæ yellowish-brown; abdomen yellowish with three  
 brown stripes; wing veins, except in basal portion margined with  
 fuscous. Length 30 mm. (♀).....*leucophaea* Doane  
 Basal joints of antennæ grayish-fuscous; abdomen yellowish fuscous,  
 stripes indistinct; hypopygium rather large, ninth tergite rather  
 broadly emarginate posteriorly, the emargination with a small exci-  
 sion in the centre; ninth sternite with large V-shaped incision. Length  
 15-17 mm.....*truncorum* Meigen
32. Thoracic vittæ very wide; pleura with indistinct, brown spots. Pleural  
 suture of hypopygium present, though indistinct. Posterior margin  
 of ninth tergite yellowish, with two black, triangular, downward pro-  
 jecting processes on its under surface; posterior margin of ninth ster-  
 nite with deep, rectangular incision. Whitish spots in all the cells.  
 Length 20-33 mm.....*pacifica* Doane  
 Mesonotum with six brown stripes; pleura gray with an oblique, brown  
 stripe. Hypopygium without pleural suture or pleural plates; ninth  
 sternite deeply and broadly emarginate. Length 20mm. (♂).....  
*subcinerea* Doane
33. Larger. Length over 20mm, testaceous.....*retorta* V. d. Wulp  
 Smaller, not exceeding 16 mm. Grayish black; posterior margins of ab-  
 dominal segments yellowish. Hypopygium large, blackish, append-  
 ages yellowish. Wings grayish-fuscous, base of first and fourth pos-  
 terior cells, whitish. Length 11 mm. (♂).....*ternaria* Loew
34. Thoracic vittæ margined.....35  
 Thoracic vittæ not margined.....52
35. Joints of flagellum unicolorous.....36  
 Joints of flagellum bicolorous.....47
36. A fuscous spot at end of longitudinal veins.....†37  
 Wings not so marked.....39
37. Larger, length 16 mm. and over.....38  
 Smaller, length 10 mm. (♂). Brown; ninth tergite with a broad crescent  
 shaped emargination. Ninth sternite with a very deep V-shaped inci-  
 sion. Neither pleural suture or pleural plates present. Basal half  
 of fifth vein broadly bordered with fuscous anteriorly. Length 10  
 mm. (♂).....*simplex* †Doane

\*olympia, see under 93. uncinata, see under 138. Simulata pratorum, see Appendix.

† pubera Loew., see 57; rupicola, see 50, and abluta, see 58, belong here.

‡ The female has rudimentary wings and should have been placed under 165—species with rudimentary wings in the female—.

38. Thoracic dorsum with two velvety black spots each side behind the transverse suture. Fuscous spot at beginning of praefurca well marked. Abdomen orange-yellow above. Hypopygium small; neither pleural suture nor pleural plates; ninth tergite with a small semi-circular emargination in its posterior margin; ninth sternite with deep, oval emargination. Length 33-36 mm. . . . . *abdominalis* Say  
 Thoracic dorsum not as above. The fuscous spot at beginning of praefurca inconspicuous. Abdomen tawny with fuscous median stripe. Hypopygium of moderate size; ninth tergite broadly emarginate in the middle and narrowly incised laterally on its posterior margin; posterior margin of ninth sternite with a deep V-shaped emargination. Length 20mm. (♀) . . . . . *camiscibilis* Doane  
*cantaminata* Daum sgn.
39. One or more posterior cells at least in part white. . . . . 40  
 Posterior cells not at all white. Body blackish; abdominal segment tipped with pale. Wings brownish towards the apex, a white spot at the exterior margin, surmounted by a fuscous spot. Length 11 mm. (♀) . . . . . *parvii* Kirby
40. First posterior cell only, white at base. Pale ochraceous. Hypopygium large, ninth tergite rounded, black. Length 11 mm. (♂) . . . . . *latipennis* Loew
- More than one posterior cell white at base. . . . . 41†
41. Lateral appendages of the ninth sternite (below the pleural appendages) without a lower pendulous, or claw like arm. Hypopygium elongated, posterior margin of ninth tergite produced in the middle in a short, broad three pointed downward-projecting tooth; ninth sternite broadly emarginate posteriorly, from the middle of which arise two long strap-like appendages. Length 18 mm. . . . . *madera* Doane  
 Lateral appendages with a lower pendulous, or claw-like arm. . . . . 42
42. Lateral appendages with only two arms. . . . . 43  
 Lateral appendages with three arms. . . . . 45
43. Lower arm of lateral appendage slender, membranous, nearly straight. Hypopygium large, ninth tergite with two pendulous processes at its posterior margin. Abdomen with a fuscous stripe each side. All posterior cells more or less white. Length 11½ mm. . . . . *fallax* Loew  
 Lower arm of pendulous appendage more strongly chitinized, claw-like, tip blackish. . . . . 44
44. Lower arm of lateral appendages short, broad, flat. Grayish brown; pleura with an interrupted brown line running from neck to base of wings; postero-lateral margins of abdominal segments grayish. Eight sternite three-lobed; posterior margin of ninth sternite with downward projecting, three toothed process; two long, slender blade like processes arise from the base of the incision of the posterior margin of the ninth sternite. Wings brownish with whitish hyaline spots in all the cells. Length 15 mm. . . . . *rohweri* Doane  
 Lower arm of lateral appendages long, slender. Subtestaceous; first posterior cell almost entirely, fourth at base, white; ninth tergite without pendulous processes. Length 12-14 mm. . . . . *grata* Loew

\*May not belong to the genus *Tipula*.

†The differentiation of the seven species under this heading, are based on the table given in Prof. Doanes' paper, entitled "*Tipula fallax* and others." Psyche Vol. XIII, pp. 160-166. In wing pattern, they, together with *Tip. hebes*, resemble each other very much and *Tip. fallax* of the West and *Tip. hebes* of the East may be looked upon as typical.

45. The two upper arms of lateral appendages consist of two small, subequal, spine-like processes. Brown; pleura hoary, a brown line running from upper angle of mesopleura to neck; abdomen yellowish-brown, darker posteriorly; ninth tergite about twice as long as wide, posterior lateral angles ending in short, blunt points; posterior margin of ninth sternite with a pair of long twisted, heavily chitinized processes. Wings brownish with a few indistinct, whitish spaces. Length 15 mm. (♂ and ♀)..... *coloradensis* Doane  
First and second arms of lateral appendages very different in size and shape..... 46
46. The blade-like processes arising from the posterior margin of the ninth sternite long, slender, sinuous. Brown; pleura grayish, with a brownish line reaching from neck to base of wing; abdomen yellowish-brown with three interrupted, brown lines. Hypopygium much elongated; extreme tip of ninth tergite produced downward into two short, sharp, curved claws; posterior margin of ninth sternite deeply notched and provided with two long, slender, sinuous, blade-like processes. Wings brownish with several whitish, hyaline spots in nearly all the cells—wing pattern scarcely distinguishable from fallax—Length 15 mm..... *alia* Doane  
The blade-like processes shorter, more triangular. Brown; abdomen with broad median and narrow lateral stripes; ninth tergite a little longer than wide, posterior margin with a pair of short, black, downward projecting processes; ninth sternite completely divided, from the incision arises a pair of rather long, thin, sharp-pointed, blade-like processes; bases of first and fourth posterior cells whitish, discal cell almost wholly white. Length 13 mm..... *neucomeri* Doane
47. First posterior cell white at base..... 48  
First and fourth posterior cells white at base..... 49  
First posterior cell not white at base..... 50
48. Smaller, 13-15 mm., ovipositor not serrulate beneath. Yellowish; pleura spotted with brown. Hypopygium large, ninth tergite large, longer than wide, narrowed posteriorly, its apex with a strongly chitinized, black, downward directed short, toothed process; ninth sternite with deep narrow incision, containing two long, slender, pointed, sickle-shaped processes; the lateral angle of the incision with a long, pendulous process. Length 13-15 mm..... *hebes* Loew  
Larger, 21 mm. Testaceous; abdomen with three fuscous stripes, lamellæ of ovipositor serrulate beneath. Wings grayish-fuscous, fourth and fifth posterior cells somewhat paler at their bases and along the vein separating the same. Length 21 mm..... *serrulata* \*Loew
49. Color gray, median line of thorax not fusiform. Abdomen trivittate; wings grayish-fuscous, no white spots along posterior wing margin. Length 19½ mm..... *discolor* †Loew  
Color yellow, median line of thorax fusiform. Abdomen trivittate, ultimate segments nearly black. Hypopygium small, ninth tergite very small, sub-orbicular; wings pale brown with about four whitish spots. Length 12 mm..... *canadensis* Loew
50. Longitudinal veins fuscous at tip; femora with a whitish band a short distance before the tip. Brown; pleura grayish brown, with an irregular line and spots dark fuscous. Ninth tergite somewhat tumid, margin reflexed and with a pair of inconspicuous, black edged teeth; pleural suture complete, ninth sternite almost hidden by eighth sternite posterior margin with two broad appendages. Length 25 mm.....  
*rupicola* †Doane  
Longitudinal veins not fuscous at tip, femora without preapical white band..... 51

\*Type minus flagellum, joints of same may be unicolorous.

†Joints of flagellum toward the base pale brown, black at base, outer joints entirely dark fuscous.

‡ Should have been placed under 37.

51. Dark cinereous; abdomen sordid testaceous, indistinctly trivittate, last two segments blackish, lateral margins of segments whitish. Hypopygium small, ninth tergite reniform. Wings grayish-fuscous, a small white spot at the posterior margin of the second basal cell, discal cell and base of fourth posterior cell indistinctly whitish. Length 14 mm.  
*centralis* Loew
- Yellowish; thorax reddish; abdomen trivittate. Hypopygium moderately large, ninth tergite membranous posteriorly, deeply emarginate in the middle, sides deflected in the form of rounded lobes; ninth sternite entire, a somewhat ellipsoidal shaped process arises from its posterior margin. Wings strongly tinged with yellow. Length 10-24 mm. . . . . *flavescens* Fabr
52. Joints of flagellum unicolorous. . . . . 53  
Joints of flagellum bicolorous. . . . . 60
53. Color grayish. . . . . 54  
Color not grayish. . . . . 57
54. Three white spots along the posterior wing-margin; middle thoracic vitta obsolete anteriorly. Abdomen testaceous, lateral margins and last segments fuscous; hypopygium subcarinate below; wings grayish. Length 9-13 mm. . . . . *fragilis* ♂ Loew  
*suspecta* ♀ Loew
- Posterior wing margin without three spots. . . . . 55
55. Scutellum and metathorax shining; former yellow with a brown line in the middle. Abdomen brownish yellow, hind margin of segments and interrupted dorsal stripe brown; hypopygium rather large, ninth tergite broader than long, posterior margin with a crescent shaped emargination; ninth sternite nearly completely divided; pleural suture almost extending to the anterior margin. Wings pale gray, veins of apical portion white margined. Length 7-16 mm. . . . . *beatula* O. S.
- Scutellum and metathorax not shining. . . . . 56
56. Abdomen shining, sutures brown, wings with three clearly defined fuscous spots along the costal margin. Length 18 mm. . . . . *frigida* Walker
- Abdomen trivittate; wings with three fuscous spots along the costal margin near the apex. Length 12 mm. . . . . *resurgens* Walker
57. Pubescens of body very conspicuous. Testaceous; thoracic stripes not very distinct. Hypopygium very large; ninth sternite large, barbed at the posterior margin with golden yellow hair. Wings grayish fuscous, anterior branch of second longitudinal vein abbreviated; most of the veins margined with fuscous; all posterior cells white margined. Length 18 mm. . . . . *pubera* \*Loew
- Pubescens of body not conspicuous. . . . . 58
58. A whitish spot before and behind the stigma. . . . . 59  
Wings not so marked. Brown; mesonotum with four brown stripes; abdomen with lateral stripes, latero-posterior margins of segments yellowish; eight and ninth segments separated above by a deep furrow; lateral margins of ninth tergite drawn out into a blunt point posteriorly, ninth sternite divided by a deep quadrate incision. Veins in apical part of wing white margined, and tipped with fuscous; similar to *commiscibilis* (*contaminata*). Length 22 mm. (♀) . . . . . *abluta* †Doane
59. The white spot before the stigma extends to base of fourth posterior cell; abdomen trivittate. . . . . 60  
The white spot before the stigma does not extend to the posterior cells. Brownish yellow. Mesonotum with four broad, brown stripes; abdomen with broken, brown lateral stripe; ninth tergite with deep, median furrow and rather deep V-shaped incision, the apex of which bears a short triangular black tipped tooth; ninth sternite with broad, deep U-shaped incision which contains a pair of large, tumid yellow haired appendages. Veins with indistinct whitish border. Length 16 mm. . . . . *californica* Doane

\* Should have been placed under 37.

† Should have been placed under 37.



60. Yellow; mesonotum quadro-vittate. Hypopygium large, ninth tergite produced into two long flattened sub-triangular processes; ninth sternite produced laterally into rather long very acute triangular appendages. The white spot extends through the fourth posterior cell to the posterior margin. Length 17 mm. (♂)..... *armata* \*Doane  
 Brown; mesonotum with three brown stripes; pleura slate colored. Posterior margin of abdominal segments paler; posterior margin of ninth tergite depressed shining black with median, short blunt process; ninth sternite with rounded emargination, containing a pair of rather long, tumid appendages. Wings gray with three conspicuous, white spots. Length 15-23 mm..... *albonotata* Doane
61. Abdomen pale yellowish, posterior margin of segments dark fuscous... *fasciata* †Loew  
 Abdomen not so marked..... 62
62. Gray; ovipositor with a large, oval piceous and shining shield above, terminated by two movable, lanceolate, serrated and ferruginous lobes; penultimate joint (of abdomen) with two long, slender spines beneath; length 21-22 mm..... *arctica* †Curtis  
 Not gray; ovipositor not so constructed..... 63
63. Fuscous; abdomen ferruginous with two fuscous stripes; thorax with pale brown stripes. Wings brownish with several whitish spots and three fuscous spots near the costal margin. Length 16 mm. (♂)..... *platymera* Walk  
 Yellowish species; abdomen trivittate..... 64
64. Thorax grayish, or yellowish gray; all the joints of flagellum bicolored. Hypopygium very large, pleural pieces greatly elongated, linear. Three or four fuscous spots near the anterior margin, fourth and fifth posterior cells partly white. Length 13-14 mm..... *macrolabis* Loew  
 Mesonotum light yellow with four brown stripes. Ninth tergite (♀) nearly concealed beneath the eight. Wings tinged with brown, a brown spot in the anterior margin of first basal cell, origin of prae-furca and over the stigma, an incomplete whitish band before the stigma extends to base of fourth posterior cell. Length 19 mm. (♀) *varia* Doane
65. Joints of flagellum bicolorous..... 66  
 Joints of flagellum unicolorous..... 69
66. Cinereous, thoracic vittæ distinct..... 67  
 Yellowish, thoracic vittæ concolorous, indistinct; apical third of wing infusate..... 68
67. White spots at end of veins; mesonotum with two brown lines, confluent anteriorly; wings dusky, three or four white spots along central veins, stigma margined white; abdomen blackish; apex of femora blackish. *maculalipennis* Say  
 No white spots at end of veins; thoracic stripes margined; abdomen yellowish-gray with three dark stripes, hypopygium small, ninth tergite small, ovate; ninth sternite absent (?). Wings pale fuscous with four pale spots; base of first and fifth posterior cells white. Length 14 mm..... *balioptera* Loew
68. The white spot before the stigma extends across the wing and attains the posterior margin. Hypopygium large, ninth tergite broadly and profoundly emarginate, the lateral angles extended into sharp points; ninth sternite nearly concealed by the large, protuberant eighth sternite, pleural plates present, small, the lower angle of the right pleural plate prolonged into a two pronged process. Length 17 mm. *speciosa* Loew  
 The white spot does not extend beyond the base of the fourth posterior cell. Smaller, and wings paler than in *speciosa*. Length 15-16 mm. *submaculata* Loew

\*See also under 20.

†See under 16.

‡Type specimens minus antennæ.

§Indistinctly seen in *T. valida*, Loew; antennæ wanting in *T. versi-color*.

69. Thoracic stripes not margined.....\*70  
 Thoracic stripes margined.....76
70. Apical third of wing infuscate; yellowish-gray; abdomen trivittate, lateral margin and posterior margin of segments whitish; ovipositor with a semi-tubular process each side at base. The white spot in front of the stigma extends across the wing and attains the posterior margin; base of third posterior cell white. Length 19-20 mm.....  
*valida* †Loew
71. Apical third of wings not infuscate.....71  
 Abdomen black or orange colored.....72  
 Abdomen not so colored.....73
72. Abdomen blackish, posterior margin of segments yellow. Black; hypopygium small, posterior margin of ninth tergite depressed with two median, longitudinal, shining black ridges; ninth sternite with a broad deep incision. Wings grayish-brown, rhomboidal, discal and fourth posterior cells almost wholly white. Length 14 mm. (♂).....  
*helvocincta* Doane
- Abdomen orange-yellow with three black, longitudinal stripes. Wings brownish, yellowish toward the costa, with about four whitish spots, first and fourth posterior cells whitish at base. Length 15½ mm. (♀)  
*versicolor* †Loew
73. Posterior cells not at all white. Head and thorax blue-black; stripes of latter indistinct; abdomen brownish yellow, first segment black, with brown lateral stripes; ninth tergite with broad, deep, crescent shaped incision; ninth sternite with deep, V-shaped incision, almost separating the segment; pleural plates distinct. Wings with four indistinct, whitish spots. Length 16 mm. (♂).....*nigrocorporis* Doane
- One or more posterior cells at least partially white.....74
74. Abdomen with median stripe. Brown; thorax with five stripes, § lateral pair confluent before and behind; a lateral black spot on each abdominal segment; whitish spots along costal border distinct, those of disc indistinct, a small brown spot near the tip. Length 20 mm.....  
*dorsimacula* Walker
- Abdomen without median stripe.....75
75. Posterior cells one and four white at base. Pale ochreous. Hypopygium moderate, ninth tergite short with two linear processes in the middle of the posterior margin, eight sternite protuberant, emarginate at apical margin and with lateral, leaflike process each side; ninth tergite with apical V-shaped emargination, pleural suture short. Wings grayish, apex a little darker, with about four not very distinct, whitish spots. Length 12 mm.....*pallida* Loew
- First posterior cell only, white at base. Grayish; thorax grayish white. Wings with several whitish spots. Length 12 mm. (♀).....*ignobilis* Loew

\**T. impudica* see 121.

†Mr. C. P. Alexander informs me that he has seen the type of *T. valida*, a female, in the Loew collection at Cambridge and that it is identical with specimens of *T. calva*, in my collection, determined as such by Prof. Doane. The type of the latter species was a male. Specimens of both species—determined as such by Prof. Doane and Mr. C. P. Alexander respectively—apparently agree in all particulars, except in coloration of the flagellar joints, which are distinctly bicolored in *calva* and nearly fuscous in *valida*. There is also a difference in the apical appendages of the two species. Loew does not mention the narrowly infuscate posterior transverse, and apical posterior of fifth veins.

‡Type, a female, minus antennæ.

§ In all probability it should read: thoracic stripes concolorous, margined.

76. Posterior cells one and four white at base. Yellowish; abdomen with three fuscous stripes; hypopygium small; ninth tergite nearly divided, lobes rounded, posterior margin of each bidentate, ninth sternite with deep V-shaped emargination, containing two hairy pendulous appendages. Wings brownish with about four conspicuous, whitish spots. Length  $14\frac{1}{2}$ -18 mm. .... *serta* Loew
77. Posterior cells one and four not white at base. .... 77
77. First and fifth posterior cells white at base. Brown, mesonotum with four brown stripes; abdomen with narrow lateral stripes; hypopygium small, ninth tergite terminating in a median, short and rather acute point. Wings grayish with faint, whitish spots, stigma surrounded by white, a large white spot covers tips of basal cell and base of discal and fourth and fifth posterior cells. Length 14 mm. ( $\sigma^7$ ). .... *subtenuicornis* Doane
78. First posterior cell only, white\* at base. .... 78
78. Wing spots distinct, posterior margin of wing not white, legs robust. Abdomen trivittate; hypopygium not large, ninth tergite short, broad, emarginate posteriorly, ninth sternite broadly and very deeply emarginate, the emargination filled by a membrane, from the posterior border of which arises a slender process which ends in two large, fleshy lobes, which are emarginate at the apex. Wings brownish, a large whitish spot, common to anal and axillary cells. Length  $14-22\frac{1}{2}$  mm. .... *angustipennis* Loew
- Wing spots very indistinct, posterior margin of wings whitish, legs slender; thoracic vittæ subconfluent; abdomen with black median stripe; hypopygium large with two large, pendulous appendages. Length  $7\frac{1}{2}$  mm. .... *appendiculata* Loew
79. Joints of flagellum unicolorous. .... 80
- Same as all the joints of flagellum bicolorous. .... 81
80. Pleura without oblique, fuscous stripe. Brown; mesonotum with three grayish-brown fuscous bordered vittæ, abdomen with broad, interrupted, brown lateral stripes, lateral margins of ninth tergite produced into short, blunt points, posteriorly; all posterior cells margined with brown. Length 16 mm. ( $\sigma^7$ ) .... *fulwilineata* Doane
- Pleura with oblique fuscous stripe. Yellowish; posterior border of abdominal segments whitish; discal cell subovate, first posterior cell without subhyaline stripe. Length 13 mm. ( $\sigma^7$ ) .... *subeluta* Johnson
81. Median vitta of wing attains the apex. .... 82
- Median vitta of wing does not attain the apex. .... 85
82. Costal stripe sinuous posteriorly. Thoracic stripes not sharply defined; abdomen with lateral fuscous stripes; hypopygium small, ninth tergite rounded posteriorly with a rounded, median process terminating its posterior margin, ninth sternite with a very deep V-shaped incision; second posterior cell small, fourth and fifth white at base. Length  $12\frac{1}{2}-16\frac{1}{2}$  mm. .... *bella* Loew
- Costal stripe not sinuous posteriorly. .... 83
83. The hyaline vitta of the wing passes through the first posterior cell to the apex; abdominal segments without dark fuscous, transverse line before the posterior margin, the latter and lateral margin of segments paler. Length 14 mm. ( $\varphi$ ) .... *eluta* Loew
- Hyaline vitta does not pass through the first posterior cell to the apex; dark transverse line before the posterior margin of the abdominal segments .... 84

\*In the male of *angustipennis* this cell is frequently not white.

84. Larger, 20-28 mm; costal border broader and more deeply fuscous; the median vitta begins about the middle of the second basal cell, basal half of anal and axillary cells whitish hyaline. Hypopygium small, exposed part of ninth tergite short, posterior margin with a median broader and two lateral, clawlike processes, ninth sternite divided to near its base by a narrow suture, posterior margin sub-triangularly emarginate, the lateral angles end in a scroll-like protuberance, pleural suture present. Length 19-25½ mm. . . . . *caloptera* Loew  
 Smaller, 19-20 mm. Costal border less intensely fuscous, the median vitta begins near the base of the second basal cell; anal and axillary cells grayish fuscous, slightly paler at the base. Hypopygium small, ninth tergite produced posteriorly into a large, lobelike process, almost as long as the exposed part of the body of the segment, ninth sternite deeply divided to near its base; pleural suture present. Length 14-20 mm. . . . . *strepens* Loew
85. The white spot before the stigma extends across the wing in form of an irregular fascia and nearly reaches the posterior margin; part of costal border posterior to subcostal cell, paler. Length 13 mm. (♀) . . . . .  
*fraterna* Loew
- The white spot does not extend beyond the base of the fourth posterior cell. . . . . 86\*
86. Abdomen without fuscous stripes; hypopygium small, ninth tergite produced posteriorly into a large, lobe-like process, at each side of the posterior margin arises a pencil of long, stiff bristles, ninth sternite deeply and rather widely divided to near its base; pleural suture present. Length 12-20 mm. . . . . *tricolor* Fahr  
 Abdomen with fuscous, lateral stripes. Length 15¼ mm. (♂) . . . . .  
*vitrea* V. d. Wuip
87. All the veins with a more or less distinct brown border. Gray, thoracic vittæ bordered with fuscous; abdomen fuscous; eight sternite distended by a tumid appendage on the ventral side of the ninth sternite, the latter with deep V-shaped incision and median suture; pleural plates present; posterior margin of ninth tergite with two close-set, black tipped projections. Wings almost hyaline with an indistinct whitish stripe in the first basal cell. Length 11 mm. . . . . *meridiana* Doane  
 Not all the veins bordered with fuscous. . . . . 88
88. Posterior cross vein and apical part of fifth longitudinal vein narrowly bordered with fuscous. . . . . 89  
 Posterior cross vein and apical part of fifth vein not so marked. . . . . 94
89. Thoracic stripes margined with fuscous. Brown; joints of flagellum unicolorous, dark brown; abdomen with lateral fuscous stripes, hypopygium rather large, black, no pleural suture or pleural plates, posterior margin of ninth tergite with two slender processes. Ninth sternite with deep, broad incision and median yellow line. Wings almost hyaline, the indistinct whitish band in front of the stigma, extends to base of fourth posterior cell. Length 17 mm. (♂) . . . . .  
*albocaudata* †Doane
- Thoracic stripes not margined. . . . . 90  
 Color yellow. . . . . 91  
 Color fuscous. . . . . 92

\*No mention of "a white spot before the stigma" is made by the author of *T. vitrea*.

†Specimens in my collection determined by Prof. Doane and agreeing with his description, show a well marked, strongly curved pleural suture.

91. Abdomen with more or less distinct fuscous stripes, lateral margins of segments broadly whitish. Joints of flagellum bicolored. Hypopygium large, eighth sternite truncate, the posterior margin with a median broad, rectangular process, lateral angles with a pair of long, rather narrow, flattened appendages; ninth tergite prolonged into two long, blunt processes; ninth sternite nearly concealed by the eight sternite; pleural plates distinct, but pleural suture nearly obliterated above. The white spot before the stigma extends to base of fourth posterior cell. Length 21 mm. (♂)..... *calva* \*Doane  
 Abdomen not striped longitudinally, posterior margin of segments yellow. Joints of flagellum approximately unicolorous, brown; posterior border of eighth sternite emarginate with two bunches of reddish yellow hair; ninth tergite produced and narrowed posteriorly, posterior margin with crescent-shaped incision, with a median pair of short, black triangular downward projecting teeth; ninth sternite divided by a membranous area, posterior margin with two pairs of small appendages. Wings hyaline, the white antestigmatic band reaches almost to the posterior border. Length 11mm. *flavomarginata* Doane
92. Small cross vein margined with fuscous; flagellum dark brown; abdomen with two broad dark brown stripes, lateral and posterior margins of segments grayish; the posterior lateral corners of the ninth tergite drawn out into a short blunt process (♀); Wings almost hyaline, hypopygium similar to that of *albocaudata*. Length 19 (♀)..... *cognata* Doane
93. Small cross vein not margined with fuscous..... 93  
 A spot over the base of the second submarginal and first posterior cells and a spot over the origin of the praefurca brown. Flagellum brown; mesonotum with four darker brown stripes, ninth tergite terminating into two short blunt processes. Wings with a brownish tinge. Length 15 mm. (♂)..... *olympia* Doane syn. *cancinna* Doane
- Without spots over base of second submarginal and first posterior cells and over origin of praefurca. Joints of flagellum unicolorous; mesonotum with three brown stripes; posterior lateral angles of eight sternite with large appendages; posterior margin of ninth tergite with rounded incision, in the middle of which are two short, sharp points; ninth sternite divided by a deep, broad, U-shaped incision, containing a pair of pendulous appendages; pleural suture complete. Length 15mm. (♂), 23mm (♀)..... *ungulata* Doane
94. Wings with dark costal stripe.....95†  
 Wings without such a stripe, though costal margin may be a trifle darker than the rest of the wing..... 99
95. Joints of flagellum bicolorous; costal stripe margined posteriorly by a subhyaline stripe. Abdomen dark yellowish, segments with a short, transverse fuscous line behind the anterior margin of segments 3-6 and a very small fuscous dot on the sides of all segments; hypopygium small, ninth tergite rounded posteriorly, impressed before and slightly notched in the middle of the posterior margin; ninth sternite compressed in its basal half into a carina; pleural suture distinct. Length 13-16mm..... *costalis* †Say.  
 Joints of flagellum not distinctly bicolorous, outer joints at least fuscous. Abdomen with fuscous stripe..... 96
96. Costal stripe interrupted before the stigma by an indistinct hyaline spot. Length 19mm (♀)..... *cunctans* Say.  
 Costal stripe not interrupted..... 97

\*See foot note on *valida*, under 70.

†*T. clara* probably belongs here. See 103.

‡Because *costalis* being preoccupied in the genus *macramaxtix*, Mr. C. P. Alexander has changed *T. costalis* to *T. Sayi*, a view which I cannot share, hence shall here retain *Say's* name.

97. Gray, posterior margin of abdominal segments grayish-brown. Hypopygium moderately large, ninth tergite broadly and deeply emarginate, the margin notched in the middle, lateral angles produced into a process, subtruncate at the apex, ninth sternite deeply divided by a U-shaped incision, the latter containing a medium lobe-like process, lateral margins of the incision emarginate, the upper angles bearing a long pendulous process. Wings light grayish fuscous. Length  $14\frac{1}{2}$ - $15\frac{1}{2}$ mm ..... *infuscata* Loew
98. Not gray, posterior margin abdominal segments not paler.....98  
 Reddish yellow, smaller. Head and thorax whitish pollinose. Hypopygium very small, compressed. Wings pale fuscous, first basal cell and margin of second a trifle paler. Length 13mm ( $\sigma$ ) ... *casta* Loew\*  
 Brown, larger. Thorax gray with four brown stripes; posterior margin of eighth sternite† with a median tuft of yellow hair between a pair of irregularly shaped, six-sided, box-like appendages; ninth tergite with the posterior-lateral angles produced into two broad, truncate projections; posterior margin of ninth sternite with rounded incision containing a pair of horn-like projections. Length 16-20mm.....  
*flavocauda* Doane
99. A vitreous spot before the stigma.....100  
 Without such a spot.....154‡
100. Spot lunate, extending to or beyond the discal cell.....101  
 Spot small, never extending beyond the second longitudinal vein.....145
101. Joints of flagellum distinctly bicolorous.....102§  
 Joints of flagellum approximately unicolorous.....110
102. Fuscous species; abdomen with three darker stripes; eight sternite with a median process.....103  
 Yellowish species, costal and subcostal cells yellowish.....104
103. Costal and subcostal cells brown. Mesonotum with four darker vittæ; posterior margin of abdominal segments paler; ninth tergite short, incised in the middle. Wings hyaline, anterior margin of anal cell fuscous, the whitish line before the stigma which extends into the base of the fourth posterior cell, very indistinct. Length 16-22mm.....  
*pellucida* Doane.  
*clara* || Doane, Syn.  
 Costal, subcostal and anterior margin of anal cells tinged with yellow. Mesonotum with three dark vittæ; lateral and posterior margins of abdominal segments paler; hypopygium small, ninth tergite with deep crescent-shaped incision, ninth sternite with deep U-shaped incision, which contains two long, tumid appendages. The white spot before the stigma reaches the extreme base of the fourth posterior cell. Length 20-27mm.....  
*inermis* Doane.
104. Abdomen with three dark, fuscous stripes, valves of ovipositor short, blade-like.....105  
 Abdominal stripes, if any, faint; if distinct, but one dorsal stripe.....106
105. Posterior margin of ninth tergite with a short, rather broad, two pointed process, posterior margin of eighth sternite with fringe of yellow hair and two strong, curved reddish bristles; ninth sternite with median depression, in which lie the tips of two short appendages; the white spot before the stigma reaches the posterior border of the discal cell. Length, 15-18mm.....  
*megaura* Doane.

\* Probably the male of *cunctans* Say., and according to Osten Sacken, synonymous.

†Original description says, "tergite," evidently a misprint.

‡Not infrequently the space before or surrounding the stigma is paler than the general color of the wing.

§Antennæ of *T. clara* not described by its author.

||Prof. Doane does not mention the antennæ.

- Posterior margin of ninth tergite with a small, subquadrate median emargination, the external posterior angles extend as upturned, hornlike processes, ninth sternite nearly concealed by the eighth, bearing on each lateral posterior angle an incurved, clawlike process. The white spot scarcely reaches the extreme base of the fourth posterior cell. Length 12mm. . . . . *bicornis* Loew Mss.
106. Thoracic vittæ and dorsal stripe of abdomen distinct; length 10 mm. . . . . *puncticornis* Macg.  
 Thoracic vittæ obsolete or indistinct. . . . . 107
107. Joints of flagellum fuscous, yellow at the base; a transverse fuscous line before the posterior margin of the abdominal segments; abdomen with lateral fuscous stripe; white ante-stigmal spot very distinct but extends as a very faint line to discal cell. Ninth tergite quadrate, posterior margin slightly emarginate in the middle with two central, digitiform processes; ninth sternite small; pleural suture present. Length 12-18 mm. . . . . *tephrocephala* Loew
- Joints of flagellum yellow, fuscous at the base; abdominal segments without transverse striae before the posterior margin; lateral angle of eight sternite with a single or a pencil of two or three setæ; lateral angle of ninth tergite ending into a sharp point. . . . . 108
108. Thoracic vittæ obsolete; posterior margin of abdominal segments gray; the white ante-stigmal spot does not enter the fourth posterior cell. Length 15 mm. (♂). Ninth sternite emarginate, the emargination containing two pendulous processes. . . . . *translucida* Doane  
 Thoracic vittæ not obsolete, though indistinct; posterior margin of abdominal segments not paler. . . . . 109
109. The white ante-stigmal spot does not reach the posterior margin of the discal cell. Ninth sternite as in *translucida*, no white spot beyond the stigma. Length 16 mm. (♂). . . . . *cincticornis* Doane  
 The white ante-stigmal spot extends into the base of the fourth posterior cell. Ninth sternite as in *translucida*; a white spot beyond the stigma. Length 15-17 mm. . . . . *cuspidata* Doane
110. Yellowish species . . . . . 111  
 Brownish-yellow species . . . . . 124  
 Grayish or fuscous species. . . . . 129  
 Blackish species (Northern). . . . . 142
111. The ante-stigmal spot does not extend into the discal cell. Mesonotum with three broad, dark brown vittæ; abdomen trivittate; eight sternite produced and narrowed posteriorly; ninth tergite very small, produced into two blunt processes posteriorly; ninth sternite large, lateral angles produced into long, tapering, twisted, hornlike processes. Length 13-14 mm. . . . . *streptocera* Doane  
 The ante-stigmal spot extends into or across the discal cell. . . . . 112
112. Posterior margin of some or all abdominal segments paler. . . . . 113  
 Posterior margin of abdominal segments not paler. . . . . 118
113. Posterior margin of all the segments paler. . . . . 114  
 Some segments without pale posterior margin. . . . . 117
114. Abdomen with three well marked brown stripes. Mesonotum with five brown lines; joints of flagellum brown, darker at the base; lateral angles of eight sternite with two incurved reddish bristles; ninth tergite with deep broad, crescent-shaped incision; ninth sternite with deep V-shaped incision, below which is a whitish, oval process. Wings hyaline ante-stigmal spot very indistinct, but reaches the base of the fourth posterior cell. Length 18-22 mm. . . . . *bisetosa* Doane  
 Abdomen yellow, darker posteriorly but without longitudinal stripes; flagellum brown; ninth tergite with deep V-shaped incision. . . . . 115  
 Abdomen reddish yellow, three indistinct stripes. *T. lamellata*, see 119.

115. Abdominal segments 6-8 mostly black. Mesonotum trivittate; ninth sternite with deep incision, containing a pair of yellow appendages; wings hyaline, a faint brown spot over origin of praefurca, ante-stigmal spot broad, distinct, reaches base of fourth and side of fifth posterior cell. Length 15-20 mm. .... *retusa* Doane  
Abdominal segments 6-8 not black. .... 116
116. Mesonotal stripes and ante-stigmal spot distinct. Eighth sternite very large with median, rectangular projection of the posterior margin; ninth sternite with deep U-shaped incision, containing a long, rather broad tumid process; pleural plates distinct; fifth vein narrowly bordered with brown. Length ( $\sigma^7$ ) 22 mm. .... *spatha* Doane  
Mesonotal stripes and ante-stigmal spot very indistinct. Eighth sternite long, narrowed posteriorly; posterior margin of ninth sternite with two processes, each bearing a tuft of hair, lateral margins with two pairs of appendages. Length ( $\sigma^7$ ) 12 mm. .... *splendens* Doane
117. Ante-stigmal spot extends to posterior margin of wing; posterior margin of abdominal segments 1-7 pale yellow. Joints of flagellum brown, yellow at the base. Mesonotum with three broad, reddish brown stripes. Abdomen trivittate, segments 8-9 wholly brown. Wings nearly hyaline. Length ( $\varphi$ ) 20 mm. .... *albofascia* Doane  
Ante-stigmal spot does not reach the posterior margin of wing. Abdomen with three stripes, posterior margin of segments 4-8 white; ninth tergite with deep, median impression bearing at its end a rather broad, sharp pointed process; ninth sternite with deep, white bordered incision which contains two pendulous appendages. Wings hyaline, a whitish spot beyond the stigma and two whitish, indistinct streaks just behind the sixth longitudinal vein. Length ( $\sigma^7$ ) 19 mm. .... *albocincta* Doane
118. A whitish spot beyond the stigma. Joints of flagellum darker at the base; three broad mesonotal stripes; three indistinct abdominal stripes; lateral angles of eight sternite with a pair of rather broad appendages; ninth tergite thick swollen with median shallow furrow, posterior margin produced each side into a blunt, swollen process, deeply emarginate between the processes; ninth sternite with rounded incision which is filled by two long triangular appendages. Wings hyaline; the ante-stigmal spot extends into the base of the fourth posterior cell. Length 21 mm. ( $\sigma^7$ ) .... *hirsuta* Doane  
Without whitish spot beyond the stigma. .... 119
119. Mesonotal vittae obsolete or very faint; abdominal stripes and ante-stigmal spots ill defined or indistinct. .... 120  
Ante-stigmal spots at least distinct. .... 121
120. Larger, 18-20 mm., thorax yellow, shining, no stripes. Flagellum brown; posterior margin of eight sternite\* with two tufts of long hair; hypopygium large; posterior margin of ninth tergite with slight median incision, lateral angles produced into short, slender acute points; ninth sternite with rather deep incision containing a pair of short appendages. Wings hyaline. .... *lucida* Doane  
Smaller, 12-13 mm. Flagellum brown; thorax not shining, stripes very faint brownish. Ninth tergite nearly completely divided, each side terminating into a point, bent at right angle to upper surface. Ninth sternite long, posterior margin with two small processes, each bearing a tuft of hair. Wings hyaline. .... *lamellata* Doane
121. Abdomen with three black stripes; ante-stigmal spot distinct; flagellum dark fuscous. .... 122  
Abdomen without such stripes; thoracic stripes very faint; ante-stigmal spot distinct extending to base of fourth basal cell. .... 123

\*In the description it says "tergite," no doubt by misprint.



122. Ante-stigmal spot extends into the bases of the fourth and fifth posterior cells, one or two irregular whitish hyaline spaces in anal and axillary cells. Mesonotum with four brown lines; posterior margin of abdominal segments gray; ninth tergite short, divided by deep median incision; ninth sternite with deep, median incision. Wings with grayish tinge. Length 15-25 mm. . . . . *impudica* Doane
- Ante-stigmal spots extends into fourth posterior cell only; no hyaline spots in anal and axillary cells. Mesonotal vittæ very distinct; ninth tergite rather short, with deep broad, V-shaped emargination; ninth sternite with triangular emargination, the anterior end of which is almost circular; eight sternite with nearly semi-circular emargination; pleural plates distinct. Length 13-18 mm. . . . . *praecisa* Loew
123. Joints of flagellum light brown, darker at the base; eighth sternite not emarginate. Ninth tergite with median furrow, lateral angles slightly produced; ninth sternite divided by a rather wide membranous portion, posterior margin with a pair of two parted appendages. Wings hyaline. Length 12 mm. . . . . *rusticola* Doane
- Joints of flagellum fuscous; eighth sternite with shallow, broad rounded incision. Hypopygium large, ninth tergite of moderate length, narrowly emarginate in the middle, apical margin of each side very slightly emarginate; ninth sternite widely and very deeply emarginate, with a broad, subtriangular process each side. Length 18 mm. . . . . *biarmata* Doane
124. Posterior margin of abdominal segments paler. . . . . 125  
Posterior margin of abdominal segments not paler; abdomen more or less distinctly trivittate. . . . . 126
125. Mesonotum yellowish with three broad brown stripes; median fuscous vitta of abdomen broad; posterior margin of eighth sternite with two median short projections; median third of ninth tergite yellow, rest brown, with broad, deep incision and median depression; ninth sternite with very broad, deep U-shaped incision, lateral margin with a pair of short processes; pleural plates distinct, produced into a long, two pointed process; ante-stigmal spot indistinct and does not reach the base of the fourth posterior cell. Length 9-11 mm. . . . . *atrisumma* Doane
- streptocera* Doane, see under 111.  
*impudica* Doane, see under 122.  
*fulviodus* Doane, see under 140.  
*albivittata* Doane, see under 117.
126. Mesonotum with four brown stripes; eighth sternite produced, not emarginate; with a rather broad, elongated round tipped flap; ninth tergite short, divided by a deep V-shaped incision; ninth sternite elongated, deeply incised, lateral margin with long, slender pointed process. Ante-stigmal spot broken, extends into base of fourth posterior cell. Length 19 mm. (♂) . . . . . *pyramis* Doane
- Mesonotum with three or five brown stripes or lines; eighth sternite emarginate at apex; ninth sternite deeply divided. . . . . 127
127. Ninth tergite small, bi-emarginate at the apex. Mesonotum with three brown stripes; scutellum yellow with median brown line; emargination of ninth sternite filled with two appendages, each terminating in a pair of backward projecting claws. Wings hyaline with slight brownish tint, stigma inconspicuous; ante-stigmal spot distinct, extends into the base of the fourth posterior cell. Length 18-27 mm. . . . . *planicornia* Doane
- Ninth tergite broadly or deeply emarginate; ante-stigmal spot reaches the base of the fourth posterior cell. . . . . 128
128. Mesonotum with three broad, brown stripes; ante-stigmal spot distinct; abdominal stripes indistinct. Emargination of eighth sternite very broad, rounded; posterior margin of ninth tergite with broad and shallow emargination, the latter with yellow border and bearing in the middle a pair of blackish, triangular teeth; emargination of ninth sternite U-shaped and containing a pair of tumid appendages. Length (♂) 16 mm. . . . . *sylvicola* Doane

- Mesonotum cinereous, with three median brown lines and two lateral, broader brown stripes; ante-stigmal spot very faint. Emargination of eight sternite very slight, rounded; emargination of ninth tergite very deep, V-shaped, latero-posterior angles sharp-pointed; lower angle of pleural plates produced into a short, blunt point. Length 12-15 mm. .... *biuncus* Doane
129. Posterior margin of abdominal segments paler. .... 130
130. Posterior margin of abdominal segments not paler. .... 137\*
130. With whitish spot beyond the stigma. .... 131
- Without such a spot. .... 133
131. Ante-stigmal spot extends through discal, fourth and fifth posterior cells to the posterior margin of the wing. Mesonotum cinereous with five brown stripes; three abdominal stripes, lateral one broader, base of first segment whitish; eight sternite produced, slightly emarginate at the apex; ninth tergite small with broad, V-shaped emargination bordered posteriorly by a yellowish, less coriaceous margin; ninth sternite deeply divided, lateral margin angulated in such a way, that the emargination is widest at the base and narrowed about the middle. Length 12-14 mm. .... *usitata* Doane
- Ante-stigmal spot does not reach the posterior margin; thorax trivittate. 132
132. Mesonotum light brown; abdomen with three longitudinal, brown stripes. Posterior margin of eight sternite broadly emarginate, the posterior margin with a fringe of thick, long, yellow hair; ninth tergite with narrow, median incision; posterior margin of ninth sternite whitish with deep median incision, on each side of which are two small appendages. Ante-stigmal spot indistinct, extends into the base of the fourth posterior cell, discal cell four times as long as wide. Length 13-14 mm. .... *barbata* Doane
- Thorax gray; abdomen without longitudinal stripes. Scutellum dark yellow; eighth sternite simple, not emarginate; hypopygium small, somewhat compressed laterally, ninth tergite small with V-shaped emargination; ninth sternite widely and very deeply divided and from the base of the emargination arises a median, digitiform, hairy process, directed horizontally backwards. Wings yellowish hyaline, veins brown, the ante-stigmal spot is inconspicuous and extends into the base of the fourth posterior cell. Length 10-14 mm. ....
133. Eighth sternite deeply divided; abdomen with three stripes. .... 133
- Eighth sternite not emarginate. .... 135
134. The lateral margins of the eight tergite end in long, slender processes; a broad blunt process arises from the base of the emargination. Mesonotum with four brown stripes; abdominal stripes indistinct; ninth tergite terminates in two short, median blunt processes; ninth sternite with deep U-shaped incision. The ante-stigmal spot distinct, interrupted at the praefurca, extends into the base of the fourth posterior cell. Length 15 mm. .... *calcarata* Doane
- Lateral margins of eighth sternite do not end in long processes; from the emargination arise two tufts of hair; ninth sternite deeply incised. .... 135
135. Mesonotum with four distinct stripes; ninth tergite with broad, shallow emargination. Abdominal stripes indistinct anteriorly, lateral margins of segments gray. Ante-stigmal spot extends into the base of the fourth posterior cell. Length 15-21 mm. .... *aequalis* Doane
- Mesonotum with three brown stripes; ninth tergite with broad, deep V-shaped incision. Abdominal stripes more distinct; ninth sternite with broad, deep depression; pleural suture very short. Ante-stigmal spot indistinct, extends into the base of the fourth posterior cell. Length 9 mm. (♂). .... *alta* Doane

\*Except fulvinodus, see under 140.

136. Mesonotum with three broad stripes, posterior margin of eighth sternite with two short acute processes; posterior margin of ninth tergite with narrow median and two broader crescent shaped incisions; ninth sternite with deep U-shaped incision, containing two tumid appendages. Ante-stigmal spot indistinct, not entering the fourth posterior cell. Length (♂) 15 mm. .... *subtilis* Doane
- Mesonotum with four, rather broad stripes; eighth sternite with a median rather broad process. Ninth tergite short, incised in the middle; ninth sternite with deep and rather broad incision. Wings hyaline; costal, subcostal and the anterior margin of the anal cells and stigma, brown; ante-stigmal spot indistinct, extends into the base of the fourth posterior cell. Length 16-22 mm. .... *clara* Doane, syn. *pellucida* Doane. (See also under 103.)
137. Small, 10 mm., general reddish-brown color; thoracic stripes obsolete.\*  
Posterior margin of segments and last three segments of abdomen dark brown. Wings light brown, veins dark brown; ante-stigmal spot reaches the posterior side of the discal cell. .... *jejuna* Johnson
- Generally larger species, color fuscous or gray. .... 138
138. Whitish streaks in anal, axillary and 2-5 posterior cells; a fuscous spot on basal transverse vein. Mesonotum with four stripes; abdomen with three rather indistinct lines; posterior margin of eight sternite with a small appendage, lateral angle with a pair of larger appendages; ninth tergite ending in two rather acute points. Wings brownish tinted, ante-stigmal spot extends into base of fourth and side of fifth posterior cells. Length 19-22 mm. .... *unicincta* Doane
- Wings without whitish streaks, no fuscous spot on basal transverse vein. .... 139
139. Eighth sternite incised. .... 140
- Eighth sternite not incised; ninth tergite and ninth sternite deeply incised. .... 141
140. No white spot beyond the stigma; ninth tergite with two small crescent-shaped incisions. Brown; mesonotum with three broad brown stripes; scutellum and metanotum with narrow brown line; abdomen trivittate lateral margin of the emargination of the eighth sternite with a pair of broad, two pointed appendages; ninth sternite divided, posterior lateral angles with a pair of elongated appendages, which again are provided with a pair of slender, long, twisted and pendulous appendages. Wings with brownish tinge, ante-stigmal spot extends into the base of the fourth posterior cell. Length 19-21 mm. .... *acuta* Doane
- A white spot beyond the stigma, posterior margin of ninth tergite with Y-shaped incision. Mesonotum with three brown stripes each of which is divided by a gray line; abdomen trivittate, posterior margin of segments yellowish; ninth sternite with rounded incision, containing a pair of whitish appendages. Wings hyaline, ante-stigmal spot very faint, broken, extends into base of fourth posterior cell. Length 12 mm. .... *fulvinodus* †Doane
141. Gray, mesonotum with three vittæ the median indistinct, a median yellow line from transverse suture to base of abdomen, anterior margin of segments of the latter paler. Hypopygium small. Wings hyaline, with slight grayish tinge, very faint lighter streaks in nearly all the cells, stigma surrounded by an indistinct whitish cloud, which is incompletely connected with a whitish spot in the base of the discal cell. Length 10-14 mm. .... *dorsolineata* Doane
- Fuscous; mesonotum with five, rather broad stripes, lateral ones connected anteriorly; abdomen trivittate; eighth sternite large, posterior margin bearing two pairs of appendages; hypopygium large; incision of ninth sternite contains a pair of rather long, somewhat curved, tumid, pendulous appendages. Wings with light brownish tinge, ante-stigmal spot extends into base of fourth posterior cell. Length 14-17 mm. .... *australis* Doane

\*No stripes mentioned in the description.

†Should have been included under 125.

142. Antennæ long, reach base of third abdominal segment ( $\sigma^7$ ); front and occiput with median black line.....143  
 Antennæ of male do not reach beyond the base of the abdomen; front and occiput without median black line.....144
143. Joints of flagellum of male very slightly constricted in the middle, three mesonotal vittæ, margined with black; abdomen with black stripe each side. A yellow stripe extends from below the humerus to base of wing and scutellum; margins of median thoracic vittæ widely diverging anteriorly; margin and lower side of scutellum yellowish; hypopygium large; eighth sternite with black hair; posterior margin of ninth tergite with a pair of conical, blunt processes. Wings pale gray, the ante-stigmal spot not connected with the discal spot; a spot beyond the stigma. Length 14-18 mm.....*strigata* Coq
- Joints 4-7 of male flagellum, strongly constricted in the middle; lateral vittæ of mesothorax obsolete, the median stripe gray, bordered with black; Abdomen sparsely clothed with short, pale yellow hair, yellow with median black vitta; hypopygium rather small, eighth sternite with sparse, short yellowish hair; ninth tergite without apical processes. White spots of wing indistinct. Length 11-13 ( $\sigma^7$ ) to 15-19 ( $\varrho$ ) mm.....*cineracea* Coq
144. Thorax with many short white hairs on its dorsum; wing spots rather distinct. Abdomen black, thinly covered with short, pale yellowish hair; base of ventral surface at least, and sometimes the hind margin of some of the segments, yellow; ventral surface of eighth sternite with pale yellow hair; hypopygium and wing-spots similar to *strigata*. Length 12-15 mm.....*tenebrasa* Coq
- Thorax without white hairs, wing spots indistinct. Mesonotal vittæ black. Abdomen black, hind margins of segments, except the first, and lateral margins yellow, sparsely covered with very short, yellowish hair; hypopygium small; hind margin of ninth tergite destitute of processes. Length 14 mm. ( $\sigma^7$ ).....*gelida* Coq
145. Fuscous species ..... 146  
 Colored otherwise ..... 149
146. Abdomen striped ..... 147
147. Abdomen without longitudinal stripes, posterior margin of abdominal segments paler\* ..... 148
- Posterior margin of abdominal segments not paler, the three longitudinal stripes black. Mesonotum with six brown lines, the median stripes broad, laterals narrow. Eighth sternite with two deep folds or depressions; posterior margin of ninth tergite with two very small points; ninth sternite with median, whitish line, lateral angles with long, slender processes; wings hyaline, one or two indistinct, whitish peristigmal spots and a similar spot in the discal cell. Length 12 mm. ( $\sigma^7$ ).....*stalactoides* †Doane
- Posterior margin of abdominal segments paler, dorsal stripe paler. Antennæ wholly brown; mesonotum gray, three very broad fuscous vittæ; lateral margin of abdominal segments paler; hypopygium small, ninth tergite with median, short rectangular process, the lateral angles of which are produced into sharp, black points; ninth sternite deeply and narrowly incised; wings with brownish tinge, middle portion somewhat whitish-hyaline; ante-stigmal spot indistinct. Length 14 mm. ( $\sigma^7$ ).....*diluta* Doane

\*Posterior margin of abdominal segments very indistinctly paler in *dejecta* Fab.

†Appears closely allied to *cineracea*, Coq.

148. Antennæ wholly fuscous; mesonotal vittæ margined. Eighth tergite scarcely visible except at the sides; eight sternite entire, not emarginate; ninth tergite with two short, blunt marginal teeth; ninth sternite with deep V-shaped incision. Wings light fuscous. Length 10-12 mm ..... *dejecta* Fab  
*fumosa* Doane syn
- Antennæ brown, basal joints yellowish; mesonotum with four brown stripes, not margined. Abdomen brown, basal segments yellowish; eight sternite very large, very slightly emarginate, lateral angles with irregular shaped appendages; ninth tergite large, the lateral angles produced into long, somewhat curved, hornlike processes, which are concave within; posterior margin between these processes with two acute, triangular teeth; ninth sternite divided by a deep, broad membranous depression; pleural plates distinct. Wings hyaline. Length 17 mm. (♂)..... *tergata* Doane
149. Head and thorax yellow. Joints of flagellum fuscous; mesonotal vittæ very faint. Abdomen yellow at base brownish posteriorly; eighth sternite produced; narrowed posteriorly, with shallow, broad emargination, lateral angles with a pair of conical processes, bearing a pair of long, curved bristles; ninth tergite with deep median furrow, posterior margin with a pair of short, broad, blunt teeth, ninth sternite with deep, shield-shaped incision the sides of which bear a pair of rectangular plates. Wings hyaline, stigma indistinct, brown; ante-stigmal spot faint. Length 18 mm. (♂)..... *bifalcata* Doane
- Head and thorax not yellow.....150
150. Head and thorax shining black. Antennæ wholly black; thorax margined with yellow; abdomen shining, sides and posterior margins of segments yellow, eighth sternite not emarginate, hypopygium small, ninth tergite small, short and almost concealed by the reflected, upper appendages; ninth sternite with suture-like incision, the posterior margin emarginate. Wings pale brown, ante-stigmal spot small but distinct. Length 9-16 mm..... *spermax* O. S.
- Head and thorax not shining black.....151
151. Head subfuscous, thorax paler; antennæ yellowish-brown, base of flagellar joints black. Lateral and posterior margin of abdominal segments paler; hypopygium small. Wings pale-brownish, stigma colorous, ante-stigmal spot not very distinct. Length 13 mm.....  
*umbrosa* Loew
- Head and thorax ferruginous.....152
152. Southern species; legs very long, thorax trivittate; posterior margin of abdominal segments paler. Length 16 mm..... *perlongipes* Johnson  
*filipes* Walker syn
- Northern species; legs not unusually long.....153
153. Posterior margin of abdominal segments paler; base of abdomen not paler, the latter with broad dorsal stripe. Length 24 mm. .... *triplex* Walker
- Base of abdomen pale, posterior margin of segments not, or indistinctly paler. Length 16-20 mm..... *duplex* Walker
154. Joints of flagellum distinctly bicolorous; yellowish species.....155
- Joints of flagellum unicolorous.....156
155. Large form; outer joints of flagellum fuscous; thorax with five stripes. Posterior margin of abdominal segments paler. Wings pale tawny, irregularly colorless behind the costal border; veins dark. Length 16 mm. .... *borealis* Walker
- Very small; all the joints of the flagellum bicolorous. Mesonotal vittæ scarcely recognizable. Posterior margins of abdominal segments slightly infuscate, hypopygium small; ninth tergite relatively large, separated from the side pieces by a distinct suture, posterior margin slightly emarginate; ninth sternite with Y-shaped incision; eighth sternite rounded posteriorly, pleural suture present, straight.  
 Length 6 mm..... *annulicornis* Say

156. Color yellow, gray or fuscous.....157  
 Color black; posterior margin of abdominal segments gray.....164
157. Basal joints of antennæ yellow.....158  
 Basal joints of antennæ not yellow.....161
158. Yellowish species.....159  
 Fuscous species.....160
159. Antennæ long, more than half the length of the body, thorax vittate.  
 Abdomen brownish. Wings grayish, stigma pale brown. Length  
 14 mm.....*disjuncta* Walker  
 Antennæ less than half the length of the body; three vittæ of thorax as  
 well as of the abdomen, faintly indicated; eighth sternite extending up  
 on the sides and much produced posteriorly, posterior margin rounded,  
 with lateral, membranous appendages; ninth tergite very large,  
 posterior angle produced into a pair of thick, heavy, slightly curved  
 horns, posterior margin with two broad, flattened teeth; ninth ster-  
 nite almost concealed by the eighth, posterior margin biemarginate.  
 Wings hyaline, costal and subcostal cells and stigma with yellowish  
 brown tinge. Length 17 mm. (♂).....*sternata* Doane
160. Abdomen with broad dorsal stripe, basal part of ninth sternite with  
 prominent carina. Mesonotum with faint trace of two cinereous lines;  
 posterior margin of abdominal segments gray; hypopygium small,  
 posterior margin of ninth tergite with crescent shaped incision; ninth  
 sternite with crescent shaped incision. Wings with brownish tinge,  
 subcostal cell and stigma slightly darker brown. Length 13-16 mm.  
*carinata* Doane  
 Abdomen with lateral and ventral stripes; ninth sternite not carinate.  
 Mesonotum with three indistinct vittæ; posterior margin of abdominal  
 segments paler; ninth sternite ending in two short, blunt points; ninth  
 sternite with deep incision, containing a pair of long, membranous  
 appendages. Wings with slight grayish tinge, stigma and veins brown  
 the fifth posterior cell is not in contact with the discal cell. Length  
 13-15 mm. ....*sulphurea* Doane
161. Gray species ..... 162  
 Fuscous species ..... 163
162. Thoracic stripes margined; lateral and posterior margin of abdominal  
 segments margined with yellowish. First antennal joint gray. Hypo-  
 pygium medium sized; ninth tergite large, convex, narrowed posteri-  
 orly and terminating into a short, rounded process; ninth sternite  
 very large, protuberant, narrowly divided, subcarinate in its basal  
 half, about the middle of the incision is a slight protuberance, densely  
 covered with short hair; pleural suture nearly straight, evanescent  
 posteriorly. Wings pale brownish, somewhat infusate at the apex,  
 veins and stigma brown. Length 8 mm. (♂).....*cincta* Loew  
 Thoracic stripes not margined, lateral ones ill defined; abdomen with  
 fuscous dorsal and ventral stripe. Head and thorax more or less  
 clothed with pale, erect soft hairs. Hypopygium small. Wings with  
 whitish tinge, veins and stigma brown. Length 9-13 mm. ....*besselsi* O. S.
163. Head with two small, tumid processes just above the base of the anten-  
 næ; abdomen with three dark fuscous stripes, posterior margin of seg-  
 ments paler. Mesonotum gray with five fuscous stripes. Hypopy-  
 gium small, ninth tergite with U-shaped incision; ninth sternite with  
 deep narrow incision. Wings with grayish tinge, somewhat darker  
 along the veins and in the middle of the cells, stigma brown, prae-furca  
 short. Length 10-14 mm. ....*biturberculata* Doane  
 Head without processes, dorsal abdominal stripe, if at all, very faint.  
 Antennæ rather long; mesonotum with median black line and two  
 lateral indistinct, paler lines. Eighth tergite concealed except later-  
 ally; hypopygium very small, ninth tergite with wide, crescent shaped  
 incision; ninth sternite with lateral appendages. Wings uniformly red-  
 dish-brown, stigma concolorous, veins brown. Length 9-10 mm. (♂).  
*illustris* Doane

164. Abdomen with distinct, reddish brown dorsal stripe, lateral margins of segments not paler. Mesonotum with three gray vittæ, median indistinct. Hypopygium small, ninth tergite with a broad lobe on each side of the posterior margin; ninth sternite with deep narrow incision, with two pairs of broad appendages. Length 13-15 mm. . . . . *rostellata* Doane  
Abdomen not striped, lateral margin of segments gray. Head and mesonotum velvety black, latter with four rather indistinct grayish lines. Hypopygium small but rather long, ninth tergite deeply incised; ninth sternite with very deep, broad incision. Wings with grayish tinge stigma brown, veins brown, except at base of discal and second submarginal cell where they are white. Length 11-15 mm. . . . . *cervicula* Doane
165. Wings of the male normally developed. . . . . 166  
Wings of both sexes\* reduced in size or rudimentary. . . . . 167
166. Wings of female about one half the size of those of the male. Brownish-yellow; basal three joints of antennæ yellow, remainder dark brown; mesonotum vittate; abdomen with three darker stripes; eighth sternite somewhat crescent shaped, lateral margin with subtriangular appendages; posterior margin of ninth tergite somewhat crescent shaped; ninth sternite almost divided by a deep narrow, U-shaped incision; pleural plates present. Wings hyaline with smoky tinge; a whitish, ante-stigmal spot extends into the base of the fourth posterior cell; a whitish spot beyond the stigma. Length 16-20 mm.; of wings, male 18 mm., female 10 mm. . . . . *Williamsi* Doane  
Wings of female much more reduced. . . . . *simplex*† Doane
167. Wings greatly reduced in size but retaining the wing-form; 4-9 mm. long. . . . . 168  
Wings reduced to mere irregular shaped pads, less than one half the length of the halteres. . . . . 169
168. Brownish yellow, thorax light yellow, stripes yellow (often indistinct). Antennæ brown, basal joints yellow; abdomen with dorsal, lateral and ventral stripes; eighth sternite with broad, shallow median incision, lateral margin with broad subtriangular plates; ninth tergite with broad, circular incision with two short, median triangular processes. Wings distorted, variable in size, veins crowded. Length, male, 15 mm.; wing 5-9 mm.; female, 22 mm.; wing 5-6 mm. . . . . *vestigipennis* Doane  
Cinereous, thorax cinereous with four rather broad, brown stripes. Antennæ brown, basal joints yellow; abdomen with dorsal and lateral stripes. Wings much reduced in size (♀), but little longer than the halteres. Length 26 mm. (♀); wings 4 mm. . . . . *sylvestra* Doane
169. Brown; antennæ wholly brown; thorax with median darker stripe; halteres rather long and slender; abdomen with broad dorsal stripe; hypopygium rather small, ninth tergite with median groove and with deep, broad U-shaped incision containing two short sharp processes; ninth sternite almost completely divided by a narrow deep, V-shaped incision. Length 4-6 mm. . . . . *quaylii* Doane

## APPENDIX.

The following two species were not included in the synopsis:

*T. pratorum* Kirby.

Head and thorax slate colored, the latter with four brown stripes; antennæ fuscous, scape yellow. Abdomen yellow, with a fuscous dorsal stripe; hypopygium black. Wings subfuscous, clouded with white in the male, one or two fuscous spots near the anterior margin, stigma black, 24mm.

Wings of female not clouded with white.

*T. simulata* Walk ♀.

Fuscous, palpi and antennæ black, the latter about one-half the length of the thorax, fuscous, scape tawny, stripes indistinct. Abdomen dull testaceous with fuscous stripe. Wings hyaline with several brown spots, which are darkest along the costa. 20mm.

\* Male of *sylvestra* not known.

† See under 37.

List and Bibliography of the North American species of the genus *Tipula* L. described since the publication of the Catalogue of the North American Diptera, by Prof. J. M. Aldrich.

- acutipleura* Doane. Annals Ent. Soc. of Amer., Vol V, p. 42. San Diego, Cal.  
*albimacula* Doane. Annals Ent. Soc. of Amer., Vol V, p. 51. Arizona.  
*alba* Doane. Psyche, Vol. XVIII, p. 161. Keyport and Olympia, Wash.  
*alta* Doane. Annals Ent. Soc. of Amer., Vol V, p. 44. Landes, Wyoming.  
*aspera* Doane. Annals Ent. Soc. of Amer., Vol. V, p. 51. Pacific Grove, Cal.  
*atrisumma* Doane. Annals Ent. Soc. of America, Vol. V, p. 42. San Diego, Cal.  
*biarmata* Doane. Annals Ent. Soc. of Am., Vol. V, p. 55. Keyport, Wash.  
*bifalcata* Doane. Annals Ent. Soc. of Am., Vol. V, p. 55. San Diego, Cal.  
*biuncus* Doane. Annals Ent. Soc. of Am., Vol. V, p. 58. Southern California.  
*californica* Doane. Annals Ent. Soc. of Amer., Vol. V, p. 49. Palo Alta, Cal.  
*coloradensis* Doane. Psyche, Vol. XVIII, p. 164. Tabernash, Col.  
*commiscibilis* Doane. Annals Ent. Soc. of Am., Vol. V, p. 61.  
Doane. Jour. N. Y. Ent. Soc. IX, 121 (contaminata).  
*cylindrata* Doane. Annals Ent. Soc. of Am., Vol. V, p. 46. San Diego, Cal.  
*derbyi* Doane. Annals Ent. Soc. of Am., Vol. V, p. 47. Stanford University, Cal.  
*flavicomis* Doane. Annals Ent. Soc. of Am., Vol. V, p. 57. Montana.  
*flavocanda* Doane. Annals Ent. Soc. of Am., Vol. V, p. 60. San Diego, Cal.  
*flavomarginata* Doane. Annals Ent. Soc. of Am., Vol. V, p. 46. San Diego, Cal.  
*fulvinodus* Doane. Annals Ent. Soc. of Am., Vol. V, p. 45. Grand Coulee, Wash.  
*fulvilineata* Doane. Annals Ent. Soc. of Am., Vol. V, p. 61.  
Doane. Jour. N. Y. Ent. Soc., IX, 124 (graphica).  
*incurva* Doane. Annals Ent. Soc. of Am., Vol. V, p. 43. Nebraska.  
*jejuna* Johnson. Prof. Boston Soc. Nat. History, Vol. XXXIV, p. 132. Wellesley, Mass.; Riverton, N. J.  
*madera* Doane. Psyche, Vol. XVIII, p. 162. Carte Madera Creek, near Stanford University; Stanford University.  
*marina* Doane. Annals Ent. Soc. of Am., Vol. V, p. 44. Palo Alta, Cal.  
*neucomeri* Doane. Psyche, Vol. XVIII, p. 163. Deer Park, Cal.  
*nigrocorporis* Doane. Annals Ent. Soc. of Am., Vol. V, p. 45. San Diego, Cal.  
*occidentalis* Doane. Annals Ent. Soc. of Am., Vol V, p. 59. San Diego, Cal.  
*olympia* Doane. Annals Ent. Soc. of Am., Vol. V, p. 61.  
Doane. Jour. N. Y. Ent. Soc., IX, 115 (concinna).  
*oropezoides* Johnson. Psyche, Vol. XVIII, p. 131. North Adams, Mass.; Framingham, Mass.; Hazelton, Pa. Dietz.  
*pacifica* Doane. Annals Ent. Soc. of Am., Vol. V, p. 48. Deer Park, Placer Co., Cal.  
*pellucida* Doane. Annals Ent. Soc. of Am., Vol. V, p. 61.  
Doane. Jour. N. Y. Ent. Soc., IX, 104 (clara).  
*planicornia* Doane. Annals Ent. Soc. of Am., Vol. V, p. 52. San Diego, Cal.  
*pyramis* Doane. Annals Ent. Soc. of Am., Vol. V, p. 53. Pyramid Lake, Nevada.  
*quaylii* Doane. Psyche, Vol. XVI, p. 18. Yuba City, Cal.  
*rohrveri* Doane. Psyche, Vol. XVIII, p. 165. Big Horn Co., Wyoming; East Bolter, Can. Dietz.  
*rupicola* Doane. Annals Ent. Soc. of Am., Vol. V, p. 50. Oak Creek Canon, Arizona.  
*rusticola* Doane. Annals Ent. Soc. of Am., Vol. V, p. 47. San Diego, Cal.  
*spatha* Doane. Annals Ent. Soc. of Am., Vol. V, p. 59. Arizona.  
*sternalis* Doane. Annals Ent. Soc. of Am., Vol. V, p. 56. Stanford University, California.  
*subeluta* Johnson. Bull. Amer. Museum Nat. History, Vol. XXXII, p. 42. Everglade, Florida.  
*sylvestra* Doane. Psyche, Vol. XVI, p. 18. Pacific Grove, California.  
*sylvicola* Doane. Annals Ent. Soc. of Am., Vol. V, p. 53. Keyport, Wash.  
*tergata* Doane. Annals Ent. Soc. of Am., Vol. V, p. 56. Pyramid Lake, Nevada.  
*ungulata* Doane. Annals Ent. Soc. of Am., Vol. V, p. 54. San Diego, Cal.  
*vestigipennis* Doane. Psyche, Vol. XV, p. 47. San Francisco, Stanford University, California.  
*vittalapennis* Doane. Annals Ent. Soc. of Am., Vol. V, p. 61.  
Doane. Jour. N. Y. Ent. Soc. IX, 119 (albovittata).  
*Williamsii* Doane. Psyche, Vol. XVI, p. 14. San Francisco, Cal.



## SOME PEMPHIGINÆ ATTACKING SPECIES OF POPULUS IN COLORADO.

By C. P. GILLETTE.

### *Thecabius populimonilis* Riley.

This species was described by Dr. Riley, who recorded it from Greeley, Colorado, and from southern Kansas. He described the alate female of the second generation taken during July, and said that it always occurred solitary in the galls. The description fits the examples that we have taken during the same month.

Thomas in his *Eighth Report as State Entomologist of Illinois*, page 205, copies Riley's description, but adds nothing to it.

Oestland in his *Synopsis of the Aphididæ of Minnesota*, page 24; and Packard in his *Forest Insects*, page 434, list this species.

Cowen in Bulletin 31, Colorado Experiment Station, page 116, listed this species as occurring at Fort Collins and Hotchkiss in Colorado, the latter place being on the western slope of the Continental Divide. Cowen also stated that only one louse seemed to reside in a gall.

Hunter lists this species in his *Aphididæ of North America*.

In the *Journal of Economic Entomology* for 1909, page 356, the writer recorded what seemed to be this species infesting the margins of the leaves of *Populus trichocarpa* at Portland, Oregon, and observed that there was but a single large louse in each gall, all of which were becoming winged, and that the young of these lice were migrating to the young leaves as soon as born, where they were forming new galls for themselves.

In 1910, the University of Nebraska published a manuscript on the "Aphididæ of Nebraska," which included notes on this family prepared by the lamented Thomas Albert Williams, which again copies the original description and extends the range of this species to Squaw Canon, Sioux County, Nebraska, and credits Professor Bruner with recording the species in Idaho and Utah.

Dr. Edith M. Patch, in Bulletin 213 of the Maine Experiment Station (June 1913) has extended the habitat of this insect to the cotton woods of Maine, where she has taken the galls and their inmates upon the leaves of *Populus balsamifera*.

In this Bulletin Dr. Patch has evidently overlooked the fundatrix or stem-mother and her gall, and has described an apterous second generation female instead.

The fundatrix of this species is undescribed and apparently has been unrecognized until the present year (1913).

On June 4, 1910, Mr. L. C. Bragg took a leaf of *Populus angustifolia* bearing the fundatrix gall, but its identity was not suspected until the gall (Plate I, figure 1) was discovered by the writer the past summer and associated with the production of the galls at Manitou and Colorado Springs on June 25th. At these places the galls were taken just as the second generation lice were beginning to leave the galls, which they do soon after birth, to go in search of the very young tender leaves at the tips of the twigs, upon which they locate, one in a place, along a line about midway between the midrib of the leaf and one of its margins, on the under side. The small galls on the tender new leaves were first seen, and a search for the source of the lice producing them resulted in the discovery of one of the pocket-like galls containing the fundatrix and a few of her newly born young, on a full grown leaf well down on the stem. This quickly solved the mystery as to the source of the lice that were producing the galls on the tender new leaves. In the next two hours a handful of these galls with their inmates were collected, and they were located in nearly every case by first finding the galls on the terminal leaves. At this time, most of the stem mothers had not begun to give birth to the young gall makers at Manitou.

The fundatrix gall, Plate I, figure 1, is very similar to the somewhat smaller galls of the later generations, (figures 9 and 10) averaging about 10 mm. in length, and is closed except for a narrow longitudinal slit opening below, which allows the young to escape as they are born. None of these young stay to feed with their mother in the gall.

#### **Description of Fundatrix, Plate I, figure 2.**

General color, slatey gray, due to a white powdery covering everywhere upon the surface of the body, without cottony threads, or with a few, only, about the lateral and posterior margins of the body. Beneath the powder, the body is of a dull, yellowish, olive green; head legs and antennæ blackish; body about 3.50 long by 2.25 broad; antenna (figure 3), .52; hind tibia, .45, hind femur, .55; beak very short, not attaining the second pair of coxæ; joints 3 and 5 of the antenna sub-

equal; joint 4 shortest; joints 1 and 2 and 4 about equal; 1 and 2 together about as long as joint 3; permanent sensoria only, and these are surrounded with cilia.

Described from specimens taken at Manitou and Colorado Springs, Colorado, June 25, 1913, by the writer.

#### **Alate Fundatrigenia.**

This seems undoubtedly to be the form originally described by Dr. Riley, and is distinguished by the sensoria of the antenna in his drawing. Riley shows three transverse sensoria on joints 4 and 5, and this is the common number in the examples we have had for study, while in the later and smaller winged sexupara there are usually no sensoria on joint 5 but the permanent one. On joint 3 (figure 4) there are from six to nine, usually seven or eight, sensoria present and there are three to four, usually three, on joint 4; two to four on joint 5, but usually three; none but the permanent sensorium on joint 6; and a well developed spine near the base of joint 3. Our examples differ from those described by Riley by being somewhat larger, as indicated by the alar expanse, which, in our examples, varies little from 9 mm.; and in the length of the body, which, in our examples, measures from 2.75 to 3.00.

#### **The Apterous Fundatrigenia.**

What I take to be this form are light cinnamon brown in color with head and tarsi black and with more or less darkened antennæ and legs. Length, 3.00; width, 1.90; antenna, .60; hind femora, .55; tibia, .45; beak very short, not reaching the second pair of coxæ; joints 1 and 2, and 4 and 5 of the antenna (figure 6), sub-equal; joint 6 longest; joint 3 nearly as long as joint 6 without the spur; joints 4 and 5, swollen and somewhat bead-like in appearance; permanent sensoria with cilia about their margins.

Described from specimens taken in the foothills near Fort Collins from July 19th to August 14th, and at Manitou August 9th.

On August 9th, I spent the day at Manitou studying this louse. The mature galls that were occupied were found inhabited in each case by one apterous female, probably a *fundatrigenia*; a few, 6 to 10, growing larvæ and pupæ, and a small number of first instar lice; some of the last were migrating to terminal leaves and forming new galls just as the young from the stem-mothers did earlier in the season. The partly grown lice that were staying with the gall-mothers seemed all to be developing into winged individuals. All that were half grown or more gave plain evidence of this, and in one gall I found a winged adult with the apterous mother and numerous pupæ and young lice. The alate louse was a sexupara and is like the many mounted specimens that we have of this form taken in former years and again this year, late in the season.

After about the 10th of August, these alate sexupara have been common in the galls at Boulder, Fort Collins and Manitou, being still common in the galls at the last named place as late as September 20th, when there were still many larvæ and pupæ.

It is difficult to account for all the gall-mothers being apterous in August and September, when we thought that all we had noticed early in the season were winged or pupæ and solitary in the galls. Probably the explanation is that the late part of the second generation, the young from the stem mother, were apterous and remained to give birth to the two forms that occur in the galls from about the last of July on through the summer. These apterous gall mothers are certainly the parents of the alate forms (sexupara) that develop with them in the galls during August and September. The young larvæ were still producing galls at Manitou, August 9th and I found very young galls as late as September 20th at Manitou this year.

#### **Late Apterous Form.**

Described from specimens taken at Boulder, August 31, 1913, by L. C. Bragg, and at Manitou, September 20 by the writer.

Upon some of the sprigs brought from Boulder young lice were still locating on tender new leaves at the tips of the twigs for the formation of new galls, though on most of the twigs terminal buds had formed. Most of these galls contained a single apterous female that was readily distinguished from the other lice in the gall by its being more orange yellow in color. I found from eight to fifteen lice in each gall, staying with their apterous mothers. The former were in many instances, adult, and always winged when fully grown, and were also all sexupara. These gall mothers were still giving birth to a few of the dark colored young that migrate from the parental gall to form new galls on the tender leaves.

The adult apterous females in these galls were different from those found at Manitou and Boulder earlier in the year, by being much smaller and by having five jointed antennæ (figure 7) instead of six in all of the many specimens examined, the fourth joint being short and bead-like, and the entire antenna very much resembling the antenna of the fundatrix. The earlier form also showed a tendency to combine joints 3 and 4 and become 5-jointed. Length of body, 1.80; antenna, .38; joint 3 as long as joint 5 with the spur; otherwise like the earlier form.

#### **Sexupara.**

This form is rather markedly different from the *Fundatrigenia* by being distinctly smaller by having fewer sensoria on the antennæ (figure 5) and by having several lice living together in a gall along with the apterous mother just described.

Length of body, 1.75 to 2.00; wing, 2.60; antenna (figure 5), .60; sensoria:—joint 3, from 4 to 7, but nearly always 5; joint 3, 2 to 4, but nearly always 3; joints 5 and 6 with permanent sensoria only; joint 3, slightly longer than 6, but not as long as joint 6 with the spur included; joints 4 and 5 about equal, permanent sensoria ciliated; sensoria on short transverse lobes or ridges which do not extend nearly around the antennal joints; spur on joint 3 rather weak.

### Sexuales.

The alate sexupara begins giving birth to the sexual forms soon after leaving the galls. Those that escaped from the galls collected August 31st, had given birth to many males and oviparous females in the breeding cage September 1st. The females are greenish in color and measure about .90 in length; the males are pale yellow in color and measure about .60 in length; neither have beaks with which to take food; about 4 to 5 of each are born from one female.

The fact that this species is on the cotton woods from the time of formation of the stem mother gall early in the summer until the development of the sexupara, it seems strongly probable that this species has no alternate host plant. The sexuales must be deposited upon the cottonwood or the stem mother could hardly be upon the leaves of these trees early in the spring.

### SUMMARY OF LIFE HISTORY.

From all the data that we have been able to gather to the present time it seems probable that the life history of this species is about as follows:

The fundatrix hatches upon the cottonwood in the spring from eggs deposited upon these trees the previous fall. These stem mothers locate between the midrib and the margin of one of the early developing leaves and produce almond shaped galls similar to those that are produced on the terminal leaves, by their descendants, later in the season. From this stem-mother gall, the young escape almost as soon as born and locate on the tender new leaves, as did their mother, between the margin and midrib, each louse being solitary and producing an almond shaped gall. Apparently the lice of this second generation all become winged at first, it is certain that many do, and leave the galls, while a portion, especially of the later lice that are born, remain apterous, stay in the galls, and give birth to a third generation. These young, like the young from the stem mother, also migrate to the new leaves to continue the production of galls, each of which harbors but one louse at first, but a portion of the young of this brood remain with the mother in the gall

and become winged sexupara, of which ten to twelve may be found in a single gall with the parent. These winged sexupara begin to emerge in the vicinity of Fort Collins about the first week of August and continue to emerge till the last of September and soon give birth to the sexual forms.

The apterous females (*fundatrigenia* or *virgogenia*), occur in leaf galls, at least from about July 17th to September 20th, a portion of their young also staying in the galls with them and becoming sexupara, and a portion migrating as soon as born to form new galls, as late as September 1st. If this interpretation is correct, the alate *fundatrigenia* in this species seems only to distribute the species from one tree to another, but we have no observations that fully confirms this hypothesis. *The Galls.* (Figures 1, 9, and 10.)

Throughout the summer the galls are started upon the very tenderest young leaves only, by first instar lice which locate on the ventral surface of the leaves. There may be from one to a large number of these galls on the leaves, the entire surface of the leaf being included in gall development very often when the lice are abundant. The galls are paler green than the remaining portions of the leaves; are long oval in general form; commonly 6 to 8 mm. in length, but may be as long as 10 mm., and always upon the upper or dorsal surface of the leaf.

While it is common to find these galls abundant upon the narrow leaved cottonwood, *Populus angustifolia*, in Colorado, we have never taken one of these galls on any of the several varieties of broadleaved cottonwoods which are more common. It is entirely possible, therefore, that the specimens recorded in this paper from other states may belong to a distinct species. The galls sent from California by Professor E. Bethel, George P. Weldon, and A. C. Maxson; from Maine by Doctor Edith M. Patch; from Michigan by Professor R. L. Pettit, and those taken by the writer at Portland, Oregon, were all from broad leaved cottonwoods. On the broad leaved cottonwoods, the galls are usually placed near the leaf margin so that the long diameter of the gall is parallel with the leaf margin.\*

---

\*Since writing the above paper Mr. George M. List has collected additional material of this species for me at Manitou, on October 18th. Some of the galls taken on this date still contain the *virgogenia* and alate sexupara as described above and many sexual males and females. Probably it is only the belated sexupara that deposit their sexual young in the galls. This completes the round of development on the cottonwood except for the egg stage, which doubtless occurs on this tree, also.

The specimens of this species in the collection have been taken as follows.

FUNDATRIX.

Manitou, Colo.,	6-25-13	<i>Populus angustifolia</i>	C. P. Gillette
Colorado Springs, Colo.	6-25-13	" "	C. P. Gillette

FUNDATRIGENIA

Horsetooth Mountain	8-8-09	<i>Populus angustifolia</i>	M. A. Palmer
Spreckles, Cal.	7-27-13	" <i>fremontei</i> (?)	A. C. Maxson
Fort Collins, Colo.	8-11-12	" <i>angustifolia</i>	L. C. Bragg
Fort Collins, Colo.	8-11-13	" "	" "
Vanderbilt, Mich		" <i>candicans</i>	R. L. Pettit
Boulder, Colo.	8-14-12	" "	L. C. Bragg
Sacramento, Cal.	8-1-13	" <i>fremontei</i>	E. Bethel
Horsetooth Mountain	7-19-09	" <i>angustifolia</i>	M. A. Palmer
Boulder, Colo.	8-25-12	" "	L. C. Bragg
Manitou, Colo.	8-9-13	" "	C. P. Gillette
Boulder, Colo.	8-31-13	" "	L. C. Bragg
Manitou, Colo.	10-18-13	" "	G. M. List

SEXUPARA.

Manitou, Colo.	8-9-13	<i>Populus angustifolia</i>	C. P. Gillette
Manitou, Colo.	10-20-08	" "	" " "
Big Thompson Canon	9-18-10	" "	" " "
Boulder, Colo.	8-31-13	" "	L. C. Bragg
Manitou, Colo.	10-18-13	" "	George M. List

SEXUALES.

Manitou, Colo.	10-18-13	<i>Populus angustifolia</i>	George M. List.
----------------	----------	-----------------------------	-----------------

**Cornaphis**, New Genus.

The genus is closely related to *Asiphum* Koch. The wax plates are absent in the fundatrix but are present in the apterous fundatrigenia; the antenna of fundatrix, 5-jointed; of fundatrigenia, 6-jointed; permanent sensoria ciliated. In the type specimens the cubitus is simple, and the fundatrix, fundatrigenia and sexupara all develop in a gall together.

**Cornaphis populi**, New Species.

Producing galls on leaves of *Populus angustifolia*, which are merely a thickened and extended portion of the margin of the leaf which folds upon the upper surface producing a moon shaped, pod-like gall of a paler green color than the surrounding foliage, and often streaked with red. Galls usually measure from 15 to 18 mm. in length, and are about one-third as thick as the extreme length (figures 11 and 12).

I have never seen more than one of these galls on a single leaf, apparently each gall develops three generations of lice within it, the fundatrix and the fundatrigenia which are apterous, and the sexupara which is alate.

On July 15, 1913, the alate form was just beginning to acquire wings about Laramie, Wyoming. At this time, the fundatrix was still in the galls in a vigorous and active condition.

*Description of Fundatrix*, Figure 13.

The general color is a slaty gray, the body being covered everywhere with a fine, white powder; the head, four spots in a transverse row on the pro-thorax, the antennæ and legs, including coxæ, black; beak attaining third coxæ; joint 2 of the antenna (figure 15) about three-fourths as long as joint 3; entire antenna, .40 long; apparently no gland plates on any part of the body; permanent sensoria surrounded with ciliary fringe; length of body 2.75. On the vertex, between the insertions of the antennæ, is a slight tubercle, which is not very prominent in the fundatrix.

**Fundatrigenia**, Figure 14.

Apparently the young of the Fundatrix are all apterous, and their offspring, the third generation, all alate sexupara. The other possibility would be for the stem mother to give birth to two sets of offspring, the earlier ones being apterous individuals which later give birth to the sexupara, and the later ones developing into sexupara directly, which does not seem at all probable.

The adult apterous fundatrigenia is of a light straw yellow color and more or less covered with white powder, but there seem to be no tufts or patches of the waxy secretion upon the body; head including a prominent frontal spine, eyes and tarsi blackish; dorsum of head, usually four patches on the pronotum in a transverse line, legs and antennæ dusky brown; beak attaining third coxæ; antennæ (figure 16) 6-jointed; third joint longest but barely exceeding joint six with the spur; joint 4 shortest, being about half as long as 3; length of body 2.50; antenna, .62. This form lives in the gall with the stem female and other descendants of the year.

Described from specimens taken at Laramie, Wyoming, July 15, 1913.

**Sexupara.**

General color, pale greenish yellow, with dusky head, antennæ and tarsi; thorax a little darker than the abdomen, length 2 to 2.25; length of wing 2.75; length of antennæ (figure 17) .90; median ocellus on a rather prominent tubercle, cauda broadly oval; joints of antenna about as follows: third joint longest, a little shorter than 4 and 5 together; joint 4 a little shorter than 5; joint 6 without spur equal to joint 5; sensoria very indistinct; about 3 to 5 broadly oval sensoria on the distal one-third of joint 3, one near the distal end of joint 4, and also the permanent sensoria on joints 5 and 6; cilia about permanent sensoria rather weak, but always present. The examples studied seem each to be able to give birth to about twelve of the sexuales.





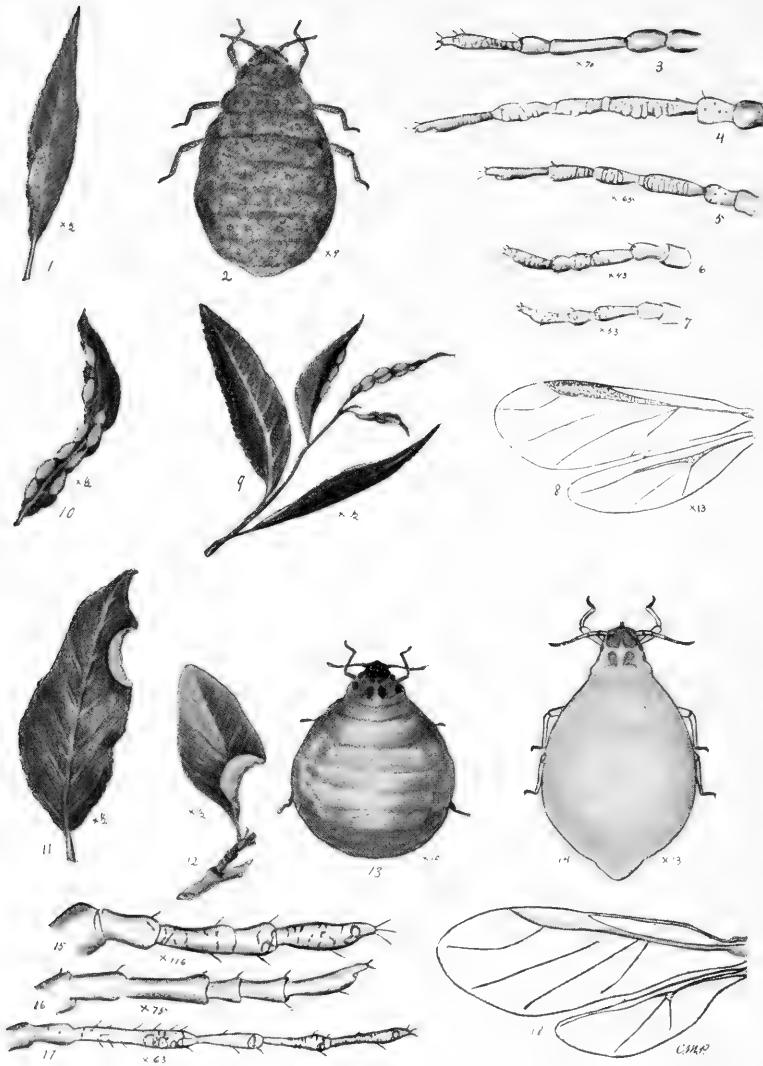

**Sexuales.**

Pale green or yellowish green in color, the males being much the smaller and darker; mouth parts lacking.

We have taken this species as follows:

Monte Vista	6-22-13	Populus angustifolius	C. P. G.	Fundatrix
La Jara	6-23-13	" "	"	"
Ft. Collins	7-10-12	" "	L. C. B.	All stages
Laramie, Wyoming	7-15-13	" "	C. P. G.	"
Wood's Landing, Wyo.	7-15-13	" "	"	"

EXPLANATION OF PLATE.

PLATE LIX.

Figures 1 to 10, *Thecabius monilis*:

- Fig. 1. fundatrix gall.
- Fig. 2. fundatrix.
- Fig. 3. Antenna of fundatrix.
- Fig. 4. Antenna of alate fundatrigenia.
- Fig. 5. Antenna of alate sexupara.
- Fig. 6. Of apterous fundatrigenia;
- Fig. 7. Alate apterous form, parent of sexupara.
- Fig. 8. Wings of fundatrigenia.
- Figs. 9 and 10. Galls, young and fully grown, on narrow leaved cottonwood.

Figures 11 to 18, *Cornaphis populi*:

- Fig. 11. Young, and Fig. 12, a rather mature gall of this species.
- Fig. 13. fundatrix.
- Fig. 14. Fundatrigenia.
- Figs. 15, 16 and 17, antenna of Fundatrix, fundatrigenia, and sexupara respectively.
- Fig. 18. Wings of sexupara.

The enlargements are indicated with each figure. Figures are drawn by Miss Caroline M. Preston.

CORRECTION: Page 486, for Plate I read Plato LIX.



## INDEX OF VOLUME VI.

- Abies*  
*amabilis*, 165, 168, 169.  
*concolor*, 162, 165, 168, 169.  
*grandis*, 162, 165, 168, 169.  
*lasiocarpa*, 163.  
*magnifica*, 162, 165, 168, 169.  
*mariesi*, 169.  
*nobilis*, 161.  
*Acanaloniidæ*, 347.  
*Acarus telarius*.  
*Achilida*, 341, 348.  
*Acinopterus*, 107.  
*Aciura insecta*, 452.  
*Acutalis*, 85, 86.  
*Aedes calopus*, 6.  
*sollicitans*, 444.  
*taeniorhynchus*, 445.  
*Agallia*, 106, 108.  
*Agromyza*, 269.  
*abbreviata*, 271, 285.  
*abnormalis*, 272, 322, 335.  
*æneiventris*, 452.  
*affinis*, 274, 317, 318.  
*amoena*, 279, 278.  
*angulata*, 273, 304, 333.  
*annulipes*, 279.  
*anthrax*, 329.  
*arctica*, 330.  
*bicornis*, 318.  
*borealis*, 271, 280, 331.  
*brevicostalis*, 271, 283.  
*blanda*, 279, 278.  
*burgessi*, 274, 323.  
*cærulea*, 274, 322, 323, 334.  
*californiensis*, 311.  
*canadensis*, 271, 299.  
*capitata*, 297.  
*citrefrons*, 272, 290, 293, 333.  
*coloradensis*, 272, 297.  
*coquilletti*, 271, 295.  
*congregata*, 274, 328.  
*coronata*, 293, 294.  
*curvipalpis*, 318.  
*davisi*, 271, 284.  
*diminuta*, 278.  
*discalis*, 271, 277.  
*dubitata*, 273, 311.  
*exilis*, 278.  
*flaviventris*, 282.  
*flavonigra*, 271, 281.  
*fragariæ*, 273, 306, 307.  
*geniculata*, 297.  
*grossicornis*, 300.  
*inconspicua*, 273, 310.  
*indecisa*, 272, 292.  
*immaculata*, 272, 289.  
*innominata*, 329.  
*insularis*, 274, 318, 319.  
*isolata*, 273, 306.  
*jucunda*, 293, 294.  
*kincaidi*, 285, 334.  
*lateralis*, 293, 294.  
*laterella*, 272, 300.  
*longispinosa*, 271, 276, 280.  
*longipennis*, 272, 296, 297, 299, 333.  
*longiseta*, 274, 326.  
*luctuosa*, 333.  
*maculosa*, 273, 302, 306, 452.  
*magnicornis*, 300.  
*malva*, 293, 294.  
*marginalis*, 283.  
*marginata*, 272, 298.  
*minima*, 274, 328.  
*melampyga*, 271, 280, 281, 282, 283, 332, 333.  
*neptis*, 286, 309.  
*nigripes*, 286.  
*nitida*, 271, 288.  
*orbona*, 279, 278.  
*parvicella*, 271, 284, 287.  
*parvicornis*, 273, 305, 310, 313.  
*picta*, 275.  
*pictella*, 280.  
*platyptera*, 272, 293.  
*plumisetæ*, 274, 324.  
*posticata*, 273, 308.  
*pruinosa*, 272, 291, 334.  
*puella*, 279, 278.  
*pumila*, 279, 278.  
*pusilla*, 271, 278, 279, 280, 452.  
*pusio*, 279, 278.  
*quadrisetosa*, 332.  
*salicis*, 273, 314.  
*schineri*, 274, 316, 326, 327.  
*scutella*, 271, 280.  
*setosa*, 273, 305.  
*simplex*, 273, 315.  
*sorsosis*, 282.  
*strigata*, 278.  
*tæniola*, 308, 309.  
*terminalis*, 308, 309.  
*texana*, 274, 319, 334.  
*tiliæ*, 274, 321, 327.  
*trifolii*,  
*variata*, 271, 277.  
*varifrons*, 272, 292, 329.  
*vibrissata*, 274, 316.  
*virens*, 274, 321.  
*viridula*, 273, 313.  
*waltoni*, 273, 303.  
*websteri*, 274, 325, 327.  
*winnemanae*, 273, 314.  
*xanthophora*, 271, 275, 276, 279.  
*xanthocephala*, 297.  
*Agromyza* Fallen, A Revision of the  
Species in, 269.

- Agromyza, Synoptic Table of, 271.  
 Allograpta obliqua, 447.  
 Ambrosia artemisiæfolia, 321.  
 American Greenbottle Flies, A Study  
 in the Variation in the North, 241  
 Amphiscepa, 343.  
 Anasa tristis, Anatomy, 427.  
 Anopheles, 8.  
 Anopheles albimanus, 6, 16, 18, 19.  
 Antherophagus megalops, 360.  
 Atenuis patescens, 359.  
 Antennal Variation, List of Figures, 236  
 Antennal Variation, A Study in, 233  
 Anthomyia lepida, 443.  
 Anthrax fulvohirta, 215.  
   impiger, 215, 222.  
   molitor, 215.  
 Archasia befragei, 87, 91.  
 Aspidiotus Perniciosus Comst., New  
   Hymenopterous Parasite on, 125.  
 Asilus, 446.  
 Attagenus aboriginalis, 361.  
   sopitus, 362.  
 Bætinæ, 387, 390.  
 Banks, Nathan, article by, 171.  
 Bee-Fly, Life-History of a, 213.  
 Bermuda, Dipteran Fauna of, 443.  
 Betten, Cornelius, article by, 65.  
 Bibliography of May-Flies, 401.  
 Biology of May-Flies, Contribution to  
   the, 371.  
 Biology of Perla Immarginata, 203.  
 Borborus minutus, 449.  
 Bombylius major, 222.  
 Brain, Chas. K., article by, 197.  
 Bryobia, 460.  
 Callidiopsites, 363.  
   grandiceps, 363, 364.  
 Calliphora  
   erythrocephala, 264, 265, 266, 267.  
   viridescens, 258, 264, 265, 266, 267.  
   vomitoria, 264, 265, 267, 447.  
 Calvert, Philip P., article by, 1.  
 Campylenchia curvata, 77.  
 Capnochoa, 365.  
   fuliginosa, 366, 365.  
   secilis, 365.  
 Carynota, 86.  
 Carynota mera, 91.  
 Cecidomyia, 445.  
 Centruchoides, 85.  
 Centrotus cornutus, 94.  
 Ceratitis capitata, 450.  
 Ceratomyza, 331.  
 Ceratopogon fur, 444.  
 Ceresa bubalus, 77, 95.  
   constans, 77.  
   diceros, 77.  
 Cerodontha dorsalis, 331.  
 Cerodontha Rondani, A Revision of the  
   Species in, 269.  
 Chætopsis ænea, 450.  
   debilis, 450.  
   fulvifrons, 450.  
 Chætotoxy of Calliphorinæ, Observa-  
   tions of the, 257.  
 Chironomus cristatus, 444.  
 Chlorotettix, 107, 108.  
 Chrysotus bermudensis, 446.  
   pallipes, 446.  
   picticornis, 446.  
 Cincindela formosa generosa, 222.  
   lepida, 222.  
   scutellaris, 213, 214.  
 Cistela antiqua, 365.  
 Cixiida, 343, 349.  
 Cleveland Meeting, 130.  
 Clisiocampa plumalis, 160.  
 Coccinella, 360.  
   sodoma, 360.  
 Coenosia, 449.  
 Colletes hirta, 222.  
 Cornaphis populi, 491, 493.  
 Cratægus, 233, 235.  
 Crosby, C. R., article by, 155.  
 Culux fatigans, 445.  
   quinquefasciatus, 445.  
   sollicitans, 444.  
   tæniorhynchus, 445.  
 Cyrtolobus, 95.  
 Cyrtolobus vau, 86, 90.  
 Delphacida, 343, 350.  
 Deltoccephalus, 108.  
 Derbida, 349.  
 Dermestes marmoratus, 361.  
   tertiarius, 361.  
 Desmometopa m-nigrum, 452.  
 Determining the Flight of Mosquitos, 5  
 Diaphorus contiguus, 446.  
 Dicranomyia, distans, 443.  
   liberta, 443.  
 Dictyophara, 344, 348.  
 Dicrocephala versuta, 104.  
 Dietz, W. G., article by, 461.  
 Dilophus breviceps, 445.  
   punctulata, 445.  
 Dipterian Fauna of Bermuda, 443.  
 Domyza nigripes, 286, 288.  
 Dræculacephala, 107, 110.  
 Drosophila adusta, 452.  
   ampelophila, 452.  
   repleta, 452.  
 Empoasca, 108, 110.  
 Enchenopa binotata, 77, 85.  
 Ensina picciola, 452.  
 Entomologist in Costa Rica, an, 1.  
 Entylia bactriana, 91.  
 Ephemerinæ, 384, 389, 391.  
 Ephydra austriana, 452.  
   nana, 452.  
 Eristallis æneus, 447.  
   tenax, 447.

- Eutettix, 107, 108.  
 Euxesta abdominalis, 450.  
   annonæ, 450.  
   pusio, 450.  
 Ewing, H. E., article by, 453.  
 Exorista, 241.  
   vulgaris, 242.  
 Exoprosopa, 215.  
   fascipennis, 223.  
 Fannia polychæta, 448.  
   pusio, 448.  
 Flatida, 347.  
 Fossil Beetles from Florissant, The  
   Princeton Collection of, 359.  
 Fucillia fucorum, 449.  
   marnia, 449.  
 Fulgorida, 347.  
 Fulgoridæ, Reference to, 351.  
 Fulgoridæ, The Wing Venation of the,  
   341.  
 Geolycosa, 216.  
 Gillette, C. P., article by, 485.  
 Goniagnathus, 107, 109.  
 Gonomyia pleuralis, 443.  
 Greenbottle Flies, A Study in the Vari-  
   ation in the North American, 241  
 Gypona, 105, 106, 108,  
 Helicobia heliciis, 447.  
 Helicopsyche, 65.  
   borealis, 66, 67.  
   minuscula, 66.  
   sperata, 67.  
 Heptageninæ, 385, 390.  
 Hermetia illucens, 445.  
 Hexagenia, 389.  
 Hippelates plebejus, 452.  
   pusio, 452.  
 Homologies of the Wing Veins of the  
   Membracidæ, 74.  
 Hordeum jubatum, 296.  
 Hymenopterous Parasite on Aspidiotus  
   pernicius Comst., 125.  
 Issida, 348.  
 Jassidæ, summary of wing structure, 112  
 Jassidæ, Wing Venation of the, 103.  
 Jassus, 106, 109.  
 Johnson, C. W., article by, 443.  
 Kolla, 104.  
 Lathyrphthalmus æneus, 447.  
 Leptocera fontinalis, 449.  
   illota, 449.  
   venalicia, 449.  
 Leptocerus, 69, 70.  
 Leptura, 364.  
   antecurrens, 364.  
   leidyi, 364.  
   sphæricollis, 364.  
 Leptophlebia, 392.  
 Limnophila insularis, 443.  
   recondita, 443.  
 Limnophora narona, 448.  
 Limosina fontinalis, 449.  
 Lispa albitarsis, 449.  
 Lochites, 168.  
 Life-History of a Bee-Fly, Parasite of  
   the Larva of a Tiger Beetle, 213.  
 Lucilia augustifrons, 253.  
   australis, 254.  
   barberi, 253.  
   cæsar, 242, 246, 249, 253, 254, 255, 256,  
     261, 448.  
   giraultie, 251.  
   infusca, 254.  
   mollis, 256.  
   morilli, 252.  
   pilatei, 254, 255, 256.  
   problematica, 448.  
   nigripalpis, 252.  
   nobilis, 256.  
   oculata, 255.  
   purpurea, 254.  
   rufipalpis, 256.  
   sericata, 241, 242, 246, 247, 249, 253,  
     257, 258, 261, 262, 264, 266,  
     267, 448.  
   sylphida, 256.  
   sylvorum, 242, 245, 247, 252, 257,  
     260, 261.  
   terræ-novæ, 256.  
   unicolor, 254.  
 Malloch, J. R., article by, 269.  
 Malva rotundifolia, 294.  
 Mansonia titillans, 19.  
 May-Flies, A Contribution to the  
   Biology of, 371.  
 May-Flies, Bibliography, 401.  
 Medeterus  
   brasiliensis, 22.  
   carbonifer, 22.  
   decora, 22.  
   dimidiata, 22.  
   floridula, 22, 24.  
   lateralis, 22.  
   lienosa, 22.  
   rubella, 22.  
   signifer, 22.  
   tenuis, 22, 24.  
 Megastigmus, 155.  
 Megastigmus, 155.  
   aculeatus, 165, 158, 160, 169.  
   albifrons, 167, 169.  
   bipunctatus, 155, 157.  
   borriesi, 169.  
   brevicaudis, 156, 169.  
   canadensis, 168.  
   cecidomyiæ, 168.  
   chloronotus, 155.  
   collaris, 155, 165.  
   cynorrhodi, 165.  
   dorsalis, 155.  
   ficigeræ, 168.  
   flavipes, 166, 169.

- flavus, 165.  
 ilinoensis, 159.  
 lasiocarpæ, 163, 169.  
 nigrovariegatus, 158, 160, 166, 169.  
 pinus, 160, 161, 163, 165, 168, 169.  
 physocarpi, 158, 169.  
 slossonæ, 157.  
 spermotrophus, 161, 163, 169.  
 strobilius, 169.  
 trassversus, 165.  
 tsugæ, 162, 169.  
 vexillum, 165.
- Megastigmus Dalman, Revision of the  
 N. A. Species of, 155.  
 Table of Hosts of, 169.
- Membracidæ, Homologies of the Wing  
 Veins of the, 74.
- Mesogramma marginatum, 447.
- Metcalf, Z. P., article by, 103, 341.
- Metriocnemus knabi, 444.
- Microbembex, 222.  
 monodonta, 222.
- Micrutalis, 86.  
 calva, 75, 90.  
 dorsalis, 87.
- Milichiella lacteipennis, 452.
- Molinnidæ, 68, 70.
- Montgomery, T. H., On the Death  
 of, 129.
- Morgan, Anna M., article by, 371.
- Mosillus nana, 452.
- Mosquitos, Determining the Flight of, 5
- Musca domestica, 447.
- Mydæa, 448.
- Myndus, 344.
- Nabalus albus, 321.
- Napomyza lateralis, 285.
- Neurigona, 22, 25.  
 æstiva, 50.  
 albospinosa, 23, 59.  
 aldrichii, 40.  
 arcuata, 45.  
 australis, 58.  
 bivittata, 51.  
 brasiliensis, 35.  
 carbonifer, 29, 32, 38.  
 ciliata, 56.  
 decora, 44.  
 deformis, 46.  
 dimidiata, 29, 30, 31.  
 disjuncta, 42.  
 flava, 40.  
 floridula, 37, 39, 43.  
 infuscata, 39, 43.  
 lateralis, 53.  
 lienosa, 52.  
 maculata, 36.  
 minuta, 60.  
 nitida, 29, 30, 33.  
 pectoralis, 48, 49.  
 perplexa, 29.  
 perbrevis, 57.  
 quadrifasciata, 22, 29.  
 rubella, 27, 29, 30.  
 setosa, 54, 56.  
 signifer, 34, 35.  
 suturalis, 23, 29.  
 tarsalis, 51.  
 tenuis, 47, 48.  
 tibialis, 55.  
 transversa, 40, 41.  
 tridens, 34.  
 viridis, 43.
- Neurigona, Table of Species, 25, 26, 27.
- Neuropterous Genus Palpares, 171.
- New Application of Taxonomic Prin-  
 ciples, 226.
- North American Species of the Dip-  
 terous Genus Neurigona, A Revi-  
 sion of the, 22.
- Observations of the Chætotaxy of  
 Calliphorinæ, 257.
- Odiina immaculata, 289.  
 ornata, 290.
- Odontocera, 331.
- Odontomyia bermudensis, 445.  
 cincta, 445.
- Ocetis, 71.  
 borealis, 73.  
 fumosa, 71.  
 incerta, 71.  
 testacea, 72.
- Officers for 1913, 127.
- Oncometopia, 106, 107.
- Ophiderma pubescens, 87, 90.
- Ophthalmomyia lacteipennis, 452.
- Ophyra ænescens, 448.
- Ormenis, 343.
- Orthocladius, 444.
- Oscinis coxendix, 452.  
 trifolii, 278.  
 trigramma, 452.  
 umbrosa, 452.
- Palpares:  
 abyssinicus, 179.  
 ægrotus, 183.  
 æmulus, 179.  
 amitus, 178.  
 angustus, 182.  
 annulatus, 183.  
 astarte, 187.  
 astutus, 189.  
 brachypterus, 186.  
 brevifasciatus, 181.  
 bifasciatus, 185.  
 burmeisteri, 180.  
 caffer, 184.  
 calceata, 183.  
 cataractæ, 178.  
 cephalotes, 179, 180.  
 chrysopterus, 183.  
 compositus, 185.



- conspucatus, 186.  
 contaminatus, 186.  
 contrarius, 188.  
 costatus, 179.  
 damarensis, 185.  
 digitatus, 184.  
 dilatatus, 183.  
 dubiosus, 184.  
 elegantulus, 185.  
 falcatus, 188.  
 festivus, 185.  
 flavofasciatus,  
 formosus, 185.  
 furfuraceus, 178, 179.  
 geniculatus, 181.  
 gigas, 177.  
 hamata, 183.  
 hispanus, 182.  
 hildebrandti, 178.  
 immensus, 180.  
 inclemens, 178, 179.  
 incommodus, 179.  
 infirmus, 188.  
 insularis, 178, 182.  
 interioris, 181.  
 kalahariensis, 180.  
 karrooanus, 180.  
 klugi, 181.  
 languidus, 183.  
 latipennis, 179.  
 lentus, 181.  
 leonina, 183.  
 libelluloides, 183.  
 lupina, 183.  
 luteus, 186.  
 manicatus, 182, 183.  
 martini, 177.  
 mcestus, 177.  
 niansanus, 181.  
 nigrita, 182.  
 normalis, 181.  
 nudatus, 178.  
 nyassensis, 185.  
 nyicanus, 178, 179.  
 obscuratus, 178.  
 obscuripennis, 177.  
 obsoletus, 181.  
 oneili, 180.  
 oranensis, 182.  
 ornatus, 183.  
 ovampoanus, 186.  
 papilionoides, 188.  
 pardalinus, 186.  
 pardaloides, 182.  
 pardina, 183.  
 pardus, 188.  
 patiens, 188.  
 percheroni, 183.  
 prætor, 179.  
 radiatus, 179, 180.  
 reticulatus, 181.  
 rieli, 179.  
 rothschildi, 186.  
 rubescens, 179.  
 similis, 180.  
 sobrinus, 178.  
 solidus, 189.  
 sollicitus, 180.  
 sparsus, 179.  
 speciosus, 178, 184.  
 spectrum, 177, 186.  
 stuhlmanni, 185.  
 subducens, 180.  
 sylphis, 183.  
 taborensis, 183.  
 tessellatus, 183.  
 tigris, 183.  
 tigroides, 189.  
 translatus, 186.  
 tristis, 181.  
 ugandanus, 181.  
 umbrosus, 184.  
 varius, 184.  
 venosus, 186.  
 voeltzkowi, 178.  
 walkeri, 177, 182.  
 zebratus, 188.
- Palpares, Explanation of Plates, 191.  
 Palpares, Indian species, 187.  
 Pamexis, 186.  
 Parabolocratas, 107, 108.  
 Paratissa pollinosa, 452.  
 Patch, Edith M., article by, 233.  
 Patrobus, 364.  
 Pemphiginæ Attacking Species of Populus in Colorado, Some, 485.  
 Perla Immarginata, Biology of, 203.  
 Phelpsius, 107, 109.  
 Phorbia fusciceps, 448.  
 Phormia regina, 255.  
 Phylia ferruginosa, 91.  
 Phyllogaster cordyluroides, 448.  
 Physocarpus opulifolius, 158.  
 Phytomyza, 452.  
 Picea bracteata, 161, 169.  
 Pinus Abies nobilis, 161.  
 Pinus ponderosa, 168.  
 Piophila casei, 452.  
 Pipunculus albisetæ, 447.  
   insularis, 447.  
 Plantago major, 282.  
 Platycentrus, 85.  
 Platycotis sagittata, 90, 91.  
 Platymetopius, 106, 108.  
 Polymitarcys, 389.  
 Populus augustifolia, 486, 490, 491.  
   balsamifera, 485.  
   candicans, 491.  
   fremontei, 491.  
   trichocarpa, 485.  
 Populus in Colorado, Some Pemphiginæ Attacking Species, 485.

- Potamanthus, 389.  
 Princeton Collection of Fossil Beetles  
     From Florissant, 359.  
 Proceedings of the Cleveland Meet-  
     ing, 130.  
 Prospaltella perniciosi, 125.  
 Pseudotsuga douglassi, 165, 169.  
     taxifolia, 165, 169.  
 Pseudopyrellia  
     cornicina, 252.  
 Psychoda alternata, 444.  
 Pteromalus aculeatus, 165.  
 Publilia concava, 91.  
 Pyrus, 233, 234.  
     sitchensis, 234, 235.  
     americana, 235.  
 Ranunculus abortivus, 285.  
 Resolutions, On the Death of T. H.  
     Montgomery, 129.  
 Resolutions, On the Death of J. B.  
     Smith, 128.  
 Revision of Agromyza and Cero-  
     dontha, 269.  
 Revision of the North American Species  
     of Megastigmus Dalman, 155.  
 Revision of the North American  
     Neurigona, 22.  
 Rosa rugosa, 160.  
 Sarcophaga assidua, 447.  
     georgina, 447.  
 Sapromyza savoria, 450.  
 Sarcophagula, 447.  
 Scaphoideus, 107.  
     auronitens, 107.  
     jucundus, 107, 108.  
 Scatopse atrata, 445.  
     pygmæa, 445.  
 Scenopinus nubilipes, 446.  
 Schizoneura, 233.  
 Sciapus chrysoprasius, 446.  
 Sciapus  
     chrysoprasius, 446.  
     pallens, 446.  
 Sciara, 445.  
 Scolops, 343.  
 Sepsis violacea, 452.  
 Shelford, Victor E., article by, 213.  
 Smilia camelus, 86, 87, 90.  
 Smith, John B., On the Death of, 128.  
 Smith, Lucy Wright, article by, 203.  
 Sorbus aucuparia, 156.  
 Spangbergiella, 106, 110.  
 Spirea, 458.  
 Spogostylum, 215.  
     anale, 222, 223.  
 Squash Bug, Anatomy of, 427.  
 Stenares, 189.  
     grandidieri, 189.  
     harpyia, 189, 190.  
     hyæna, 189, 190.  
     improbis, 189, 190.  
     irroratus, 189, 190.  
     madagascariensis, 190.  
     sinuatus, 189, 190.  
 Stegomyia calopus, 444.  
     fasciatus, 444.  
 Stictocephala, 85.  
 Stictocephala lutea, 90.  
 Stobæra, 343.  
 Stomoxys Calcitrans Linn, Part II,  
     197, 447.  
 Study in Antennal Variation, A, 233.  
 Synthesiomia brasiliiana, 447.  
 Syntomaspis, 155.  
 Tabanus atlanticus, 445.  
     nigrovittatus, 446.  
 Taxonomic Principles, New Applica-  
     tion of, 226.  
 Telemona ampelopsidis, 77, 90.  
 Telemonanthe, 86.  
     pulchella, 86.  
 Telephorus humatus, 362.  
 Tetanocera  
     kincaidi, 449.  
     pictipes, 450.  
     setosa, 450.  
     spinicornis, 449, 450.  
     umbrarum, 450.  
 Tettigoniella, 104.  
 Tetranychus, The Taxonomic Value of  
     the Character of the Male Geni-  
     tal Armature in the Genus, 453.  
     bimaculatus, 455, 456.  
     borealis, 454, 457, 458.  
     flavus, 454, 458.  
     gloveri, 455, 457.  
     longipes, 454.  
     2-maculatus, 455.  
     mytilaspidis, 454.  
     pratensis, 454.  
     sexmaculatus, 455, 457.  
     telarius, 454, 455, 456, 457, 458.  
     weldoni, 454, 457.  
 Thecabius populimonilis, 485.  
 Tipula  
     abdominalis, 466.  
     abluta, 468.  
     acuta, 479.  
     acutipleura, 464, 484.  
     æqualis, 478.  
     alara,  
         albocaudata, 472.  
         albobocincta, 476.  
         albimacula, 463, 484.  
         albofascia, 476.  
         albonotata, 469.  
         albovittata, 463.  
     alia, 467, 484.  
     alta, 478, 484.  
     angulata, 463.  
     angustipennis, 471.  
     annulicornis, 481.

- anstralis, 479.  
 apicalis, 463.  
 appendiculata, 471.  
 arctica, 469.  
 armata, 464, 469.  
 aspersa, 463, 484.  
 atrisumma, 477, 484.  
 balioptera, 469.  
 barbata, 478.  
 beatula, 468.  
 bella, 471.  
 besselsi, 482.  
 biarmata, 477, 484.  
 bicornis, 475.  
 bifalcata, 481, 484.  
 bisetosa, 475.  
 bituberculata, 482.  
 biuncus, 478, 484.  
 borealis, 481.  
 calcarata, 478.  
 casta, 474.  
 californica, 469, 484.  
 caloptera, 472.  
 calva, 473.  
 canadensis, 46.  
 carinata, 482.  
 centralis, 468.  
 cervicula, 483.  
 cincta, 482.  
 cincticornis, 475.  
 cineracea, 480.  
 clara, 474, 479.  
 cognata, 473.  
 coloradensis, 467, 484.  
 commiscibilis, 466, 484.  
 concinna, 473.  
 contaminata, 466.  
 costalis, 443, 473.  
 cunctans, 473.  
 cuspidata, 475.  
 cylindrata, 463, 484.  
 decora, 463.  
 dejecta, 481.  
 derbyi, 464, 484.  
 diluta, 480.  
 discolor, 467.  
 disjuncta, 482.  
 dorsimacula, 470.  
 dorsolineata, 479.  
 duplex, 481.  
 eluta, 471.  
 fallax, 466.  
 fasciata, 463, 469.  
 filipes, 481.  
 flavicoma, 484.  
 flavescens, 468.  
 flavocauda, 474, 484.  
 flavomarginata, 473, 484.  
 fragilis, 468.  
 fraterna, 472.  
 frigida, 469.  
 fuliginosa, 463.  
 fulvilineata, 471, 484.  
 fulvinodus, 477, 479, 484.  
 fumosa, 481.  
 gelida, 480.  
 grata, 466.  
 graphica, 471.  
 hebes, 467.  
 helvocincta, 470.  
 hirsuta, 476.  
 ignobilis, 470.  
 impudica, 477.  
 incisa, 463.  
 incurva, 464, 484.  
 inermis, 474.  
 infuscata, 474.  
 illustris, 482.  
 jejuna, 479, 484.  
 lamellata, 475, 476.  
 latipennis, 466.  
 leucophæa, 465.  
 longiventris, 465.  
 lucida, 476.  
 macrolabis, 469.  
 maculatipennis, 469.  
 madera, 466, 484.  
 marina, 464, 484.  
 megaura, 474.  
 meridiana, 472.  
 neucomeri, 467, 484.  
 nigrocorporis, 470, 484.  
 occidentalis, 464, 484.  
 olympia, 473, 484.  
 oropezoides, 478, 484.  
 pacifica, 465, 484.  
 pallida, 470.  
 parrii, 466.  
 pellucida, 474, 479, 484.  
 perlongipes, 481.  
 planicornia, 477, 484.  
 platymera, 469.  
 præcisa, 477.  
 pubera, 468.  
 pratorum, 483.  
 puncticornis, 475.  
 pyramis, 477, 484.  
 quaylii, 483, 484.  
 resurgens, 468.  
 retorta, 465.  
 retusa, 476.  
 rohweri, 466, 484.  
 rostellata, 483.  
 rupicola, 467, 484.  
 rusticola, 477, 484.  
 septentrionalis, 465.  
 serrulata, 467.  
 sarta, 471.  
 simplex, 465, 483.  
 simulata, 483.  
 spatha, 476, 484.  
 spectabilis, 463.

- speciosa*, 469.  
*spernax*, 481.  
*splendens*, 476.  
*stalactoides*, 480.  
*sternata*, 482, 484.  
*strepens*, 472.  
*streptocera*, 474, 477.  
*strigata*, 480.  
*subcinerea*, 465.  
*subeluta*, 471, 484.  
*sub-fasciata*, 464.  
*submaculata*, 469.  
*subtenuicornis*, 471.  
*subtilis*, 479.  
*sulphurea*, 482.  
*suspecta*, 468.  
*sylvestra*, 483, 484.  
*sylvicola*, 477, 484.  
*tenebrosa*, 480.  
*tephrocephala*, 475.  
*tergata*, 481, 484.  
*ternaria*, 465.  
*tesselata*, 465.  
*translucida*, 475.  
*trivittata*, 462.  
*tricolor*, 472.  
*triplex*, 481.  
*tristis*, 464.  
*truncorum*, 465.  
*ungulata*, 473, 484.  
*umbrosa*, 481.  
*unicincta*, 479.  
*usitata*, 478.  
*valida*, 470.  
*varia*, 469.  
*versicolor*, 470.  
*vestigipennis*, 483, 484.  
*vitrea*, 473.  
*vittatapennis*, 463, 484.  
*williamsii*, 483, 484.  
*Tipula*, L., Synopsis of the Described  
     N. A. Species of the Dipterous  
     Genus, 461.
- Torymus collaris*, 165.  
     *dorsalis*, 155.  
     *punctum*, 165.  
 Tothill, John D., article by, 241.  
 Tower, Daniel G., articles by, 125, 427.  
*Toxomerus marginatus*, 447.  
 Townsend, Chas. H. T., article by, 226  
*Trypeta humilis*, 452.  
*Trypherus*  
     *aboriginalis*, 362.  
     *latipennis*, 362.  
*Tsuga hookeriana*, 162, 169.  
*Tylopelta*, 85.  
*Typhlocyba*, 106, 107, 108.  
*Typhlocybidæ*, 110.  
*Ulmus*, 233.  
     *campestris*, 455.  
*Urophora fulvifrons*, 450.  
 Van Duzee, M. C., article by, 22.  
*Vanduzeea arquata*, 75, 77, 84.  
 Whiting, Phineas W., article by, 257.  
 Wickham, H. F., article by, 359.  
 Wing Veins of the Membracidæ, Homologies of, 74.  
 Wing Venation of the Fulgoridæ, The, 341.  
 Wing Venation of the Jassidæ, 103.  
*Xantholobus trilineatus*, 87.  
*Xestobium alutaceum*, 363.  
 Zetek, James, article by, 5.  
*Zizania aquatica*, 306.
- 
- Dates of issue for *Annals*, 1913,  
 Vol. VI.  
     No. 1, (March) April 16, 1913.  
     No. 2, (June) June 19, 1913.  
     No. 3, (Sept.) Oct. 23, 1913.  
     No. 4, (Dec.) Jan. 3, 1914.

ANNALS  
OF  
The Entomological Society of America

---

MARCH, 1913

---

EDITORIAL BOARD

J. H. COMSTOCK,  
ITHACA, N. Y.

L. O. HOWARD,  
WASHINGTON, D. C.

C. J. S. BETHUNE,  
GUELPH, ONTARIO, CANADA.

W. M. WHEELER,  
BOSTON, MASS.

C. W. JOHNSON,  
BOSTON, MASS.

P. P. CALVERT,  
PHILADELPHIA, PA.

V. L. KELLOGG,  
STANFORD UNIV., CAL.

J. W. FOLSOM,  
URBANA, ILLS.

HERBERT OSBORN, Managing Editor,  
COLUMBUS, OHIO.

---

PUBLISHED QUARTERLY BY THE SOCIETY  
COLUMBUS, OHIO

# ANNALS

OF

## The Entomological Society of America.

### CONTENTS OF VOLUME I.

- Proceedings of first three meetings; Constitution, By-Laws and List of Members.  
WHEELER, WM. M.—Polymorphism of Ants.  
OSBORN, HERBERT—The Habits of Insects as a Factor in Classification.  
SEVERIN, H. H. AND SEVERIN, H. C.—Anatomical and Histological Studies of the Female Reproductive Organs of the American-Saw fly, *Cimbex Americana*, Leach.  
FELT, E. P.—Some Problems in Nomenclature.  
HAMMAR, A. G.—On the Nervous System of the Larva of *Corydalis cornuta* L.  
BRADLEY, J. C.—A Case of Gregarious Sleeping Habits among Aculeate Hymenoptera.  
DAVIS, J. J.—Notes on the Life History of the Leafy Dimorph of the Boxelder Aphid, *Chaitophorus negundinis* Thos.  
HAMBLETON, J. C.—The Genus *Corizus*, with a Review of the North and Middle American Species.  
LYMAN, H. H.—The Entomological Society of America and its work.  
GIRAULT, A. A.—Biological Notes on Colorado Potato Beetle.  
GIRAULT, A. A.—A Monographic Catalogue of the Mymarid Genus *Alaptus*.  
SEVERIN, H. H. AND SEVERIN, H. C.—Internal Organs of Reproduction of Male Saw-fly.  
SMITH, C. P.—A Preliminary Study of the Araneæ of Theraphosæ California.  
DAVIS, J. J.—Studies on Aphididae.  
RILEY, W. A.—Muscle Attachment of Insects.  
NEEDHAM, J. C.—Critical Notes on the Classification of the Corduliinae (Odonata).  
HOWARD, L. O.—A Key to the Species of *Prospaltella* with Table of Hosts and Descriptions of Four New Species.  
HOOD, J. D.—Two New Species of *Idolothrips*.

### CONTENTS OF VOLUME II.

- COMSTOCK, J. H.—A Note on the Habits of the Wall-bee *Chalicodoma Muraria*.  
PETRUNKEVITCH, A.—Contributions to Our Knowledge of the Anatomy and Relationships of Spiders.  
GIRAULT, A. ARSENE—A Monographic Catalogue of the Mymarid Genus *Campoptera* Foerster, with Description of One New North America Form.  
DAVIS, JOHN J.—Studies on Aphididae II.  
HILTON, WILLIAM A.—The Tracheal Supply in the Central Nervous System of the Larva of *Corydalis Cornuta*.  
NELSON, JAS. A.—Evolution and Adaption in the Palpus of Male Spiders.  
WEBSTER, F. M.—Investigations of Toxoptera Graminum and Its Parasites.  
HAYHURST, PAUL—Observations on a Gall Aphid (*Aphis Atriplicis* L.).  
PATCH, EDITH M.—Homologies of the Wing Veins of the Aphididae Pysyllidae, Aleurodidae, and Coccidae.  
HINE, JAMES S.—Robberflies of the Genus *Asilus*.  
CHAMBERLAIN, RALPH V.—Some Records of North American Geophilidae and Lithobiidae, with Description of New Species.  
DAVIS, JOHN J.—Two New Genera and Species of Aphididae.  
POULTON, PROF. E. B.—Mimicry in the Butterflies of North America.  
TOWNSEND, CHAS. H. T.—Descriptions of New Genera and Species of Tachinidae.  
COCKERELL, T. D. A.—Fossil Insects from Florissant.  
MCGILLVRAY, A. D.—A Synopsis of the North American Species of Scolioneurinae.  
HAMBLETON, J. C.—Life History of *Coizus Lateralis* Say.

### CONTENTS OF VOLUME III.

- BRADLEY, J. C.—Minutes of the Boston Meeting.  
SMITH, J. B.—Abstract of Address, Insects and Entomologists, Their Relations to the Community at Large.  
WEBSTER, F. M.—A Predaceous and Supposedly Beneficial Mite, *Pediculoides*, Becomes Noxious to Man.  
BANKS, NATHAN—Myrmeleonidae from Australia.  
WILLIAMS, FRANCIS X.—The Anatomy of the Larva of *Cecidomyia Resinicoloides* Williams.  
MITZMAIN, M. B.—Some New Facts in the Bionomics of the California Rodent Fleas.  
SEVERIN, H. H. P.—A Study on the Structure of the Egg of the Walking Stick *Diaperomera femorata* Say; and the Biological Significance of the Resemblance of Phasmid Eggs to Seeds.  
FORBES, W. T. M.—A Structural Study of Some Caterpillars.  
MORGAN, T. H., and SCHULL, A. F.—The Life Cycle of *Hormaphis hamamelidis*.  
HEADLEE, T. J.—An Apparatus for the Determination of Optimums of Temperature and Moisture.  
SMITH, JOHN B.—Notes on Certain Species of Mamestra.  
COMSTOCK, J. H.—The Palpi of Male Spiders..  
WHITMARSH, R. D.—North American Paniscini.  
EWING, H. E.—The Rediscovery of a Peculiar Genus and Species of Oribatidae.  
VAN DUZEE, E. P.—A Revision of the American Species of *Platymetopius*.  
CHAMBERLIN, R. V.—Diplopoda from the Western States.  
HASEMAN, L.—The Structure and Metamorphosis of the Alimentary Canal of the Larva of *Psychoda alternata* Say.  
WILSON, H. F.—A Key to the Genera of the Sub-family Aphidinae and Notes on the Synonymy.

### CONTENTS OF VOLUME IV.

- NATHAN BANKS—Notes on African Myrmeleonidae.  
RALPH V. CHAMBERLIN—The Lithobiomorpha of the Southeastern States.  
WILSON, H. F.—Notes on the Synonymy of the Genera Included in the Tribe Lachninae.  
FELT, E. P.—Summary of the Food Habits of American Gall Midges.  
JENSEN, J. P.—The Structure and Systematic Importance of the Spermatophores of Crickets.  
HERRICK, GLENN W.—Notes on the Life History of the Larch Case-Bearer (*Coleophora laricella*).  
GIRAULT, A. A. and ZETEK, JAMES—Further Biological Notes on the Colorado Potato Beetle *Leptinotarsa 10-lineata* Say.  
SANDERS, J. G.—Minutes of the Minneapolis Meeting.  
MORGAN, ANNA H.—Mayflies of Fall Creek.  
TOWNSEND, C. H.—Announcements of Further Results Secured in the Study of Muscoid Flies.  
HINE, J. S.—Robberflies of the Genera *Promachus* and *Proctacanthus*.  
BURGESS, A. F.—Locomotion of the Larva of *Calosoma Sycophanta*.  
WEBSTER, R. L.—Notes on the Pear Slug.  
SEVERIN, H. H. P. and H. C.—The Mechanism in the Hatching of the Walking Stick *Diaperomera Femorata* Say.  
COCKERELL, T. D. A.—Some Suggested Rules to Govern Entomological Publications.  
MUTTKOWSKI, R. A.—The Composition of Taxonomic Papers.  
HILTON, W. A.—The Structure of the Central Nervous System of *Corydalis* Larva.  
FORBES, W. T. M.—A Structural Study of the Caterpillars II. The Spingidae.  
PALMER, MIRIAM A.—Some Notes on Heredity in the Cocconellid Genus *Adalia*, Mulsant.  
SMITH, P. E.—Specific Characters Used in the Genus *Pseudococcus*.  
TOWNSEND, C. H.—Corrections to my paper in the June (1911) Issue of the ANNALS.  
FULLAWAY, D. T.—Monograph of the Gall-Making Cynipidae (Cynipinae) of California.  
TITUS, E. G.—The Genera *Hypera* and *Phytonomus* in America North of Mexico.

## CONTENTS OF VOLUME V.

- Officers, Constitution and List of Members.  
COMSTOCK, J. H.—The Evolution of the Webs of Spiders.  
BANKS, NATHAN—Notes on the Eastern Species of *Cerceris* (Hym. Philanthide).  
WODSEDAK, J. E.—Natural History and General Behavior of the Ephemeroidea  
Nymphs *Heptagenia Interpunctata* (Say).  
DOANE, R. W.—New Western Tipula.  
OSBORN, H.—Faunistic Studies in Entomology.  
OSBORN, H.—A Problem in the Flight of Insects.  
MATHESON, R. and CROSBY, C. R.—Notes on Aquatic Hymenoptera.  
Resolutions.  
MACGILLIVRAY, A. D.—Proceedings of the Washington Meeting.  
MORGAN, A. H.—Homologies in the Wing Veins of May Flies.  
STRICKLAND, E. H.—The Pezomachini of North America.  
CHAMBERLIN, R. V.—The North American Chilopods and Diplopods.  
BRAIN, C. K.—Contribution to the Knowledge of Mealy Bugs, Genus *Pseudococcus*  
in the Vicinity of Cape Town, South Africa.  
BRUES, CHARLES T.—Brazilian Ichneumonidae and Braconidae Obtained by the  
Stanford Expedition.  
MACGILLIVRAY, ALEX. D.—The Lacinia in the Maxilla of the Hymenoptera.  
MACGILLIVRAY, ALEX. D.—The Pupal Wings of *Hepialus Thule*.  
PETERSON, ALVAH—Anatomy of the Tomato-Worm Larva, *Protoparce Carolina*.  
RILEY, C. F. CURTIS—Observations of the Ecology of Dragon-Fly Nymphs: Re-  
actions to Light and Contact.  
OSCAR C. BARILETTI—The North American Digger Wasps of the Subfamily  
*Scolinae*.  
ALEXANDER, CHARLES P.—New Neotropical Tipulinae.  
WODSEDAK, J. E. Life History and Habits of *Trogoderma Tarsale* (Melsh), a  
Museum Pest.  
JOHNSTON, CARL E.—The Internal Anatomy of *Icerya Purchasi*.  
GEE, WILSON P., and LATHROP, F. H.—Death Feigning in *Conotrachelus Nenuphar*  
Herbst.  
SEVERIN, HENRY H. P., and WM. J. HARTUNG—The Flight of two Thousand  
Marked Male Mediterranean Fruit Flies (*Ceratitis capitata* Wied).  
WELCH, PAUL S.—Observations on the Life History of a New Species of *Psychoda*.  
BRAIN, CHARLES K.—*Stomoxys calcitrans* Linn.

---

The above tables of contents for the five volumes of ANNALS now completed, will indicate the scope of the Journal and its place in Entomological Science.

These volumes may still be had at the original subscription price of \$3.00 per volume (post paid in the U. S.). The volume for 1913 promises to be larger and more important than any preceding. Parties desiring to complete their series or to secure the entire set should address

**ANNALS ENTOMOLOGICAL SOCIETY OF AMERICA,**  
Biological Building, State Univ., Columbus, Ohio.



## NOTICE TO MEMBERS AND CONTRIBUTORS.

---

The Annals of the Entomological Society of America, published by the Society quarterly, includes the Proceedings of the Annual meetings and such papers as may be selected by the Editorial Board.

Papers may be submitted to any member of the Editorial Board and should be as nearly as possible in the form desired as final, preferably typewritten, and illustrations must be finished complete ready for reproduction. Plates must not exceed 5x7 inches unless intended to fold. In general, papers to be accepted must be original, complete and previously unpublished and, except in connection with the proceedings, it will not be the policy to publish preliminary announcements or notes. Authors will be allowed fifty reprints gratis and additional copies at cost to the Society.

The Managing Editor is provided with the most recent address of all members on record in the Secretary's office for mailing the numbers of the Annals and hereafter members complaining of the non-receipt of numbers must present their complaint to the Secretary within four months from the date of the mailing of the issue. After that time the numbers will be furnished only at the regular published rate.

Requests for information as to membership and the annual subscription and dues of members may be sent to the Secretary-Treasurer, A. D. MacGillivray, 603 Michigan Ave., Urbana, Ill.

Communications relating to the ANNALS, and all orders for separate copies or reprints should be addressed to the Managing Editor or to

ANNALS OF THE ENTOMOLOGICAL SOCIETY OF AMERICA,  
Biological Building, State Univ., Columbus, Ohio.

## CONTENTS OF THIS NUMBER.

---

TOWER, D. G.—The External Anatomy of the Squash Bug .....	427
JOHNSON, CHAS. W.—The Dipteran Fauna of Bermuda .....	443
EWING, H. E.—The Taxonomic Value of the Characters of the Male Genital Armature in the Genus <i>Tetranychus</i> Dufour .....	453
DIETZ, W. G.—A Synopsis of the Described North American Species of the Dipterous Genus <i>Tipula</i> L. ....	461
GILLETTE, C. P.—Some Pemphiginæ Attacking Species of <i>Populus</i> in Colorado .....	485

---

---

The regular annual subscription price for the ANNALS is in the United States, Cuba, Porto Rico, Hawaii and Mexico, \$3.00; Canada, \$3.50; other countries, \$4.00. Checks, drafts or money orders should be drawn payable to ANNALS ENTOMOLOGICAL SOCIETY OF AMERICA, and addressed to Biological Building, State Univ., Columbus, Ohio, U. S. A.





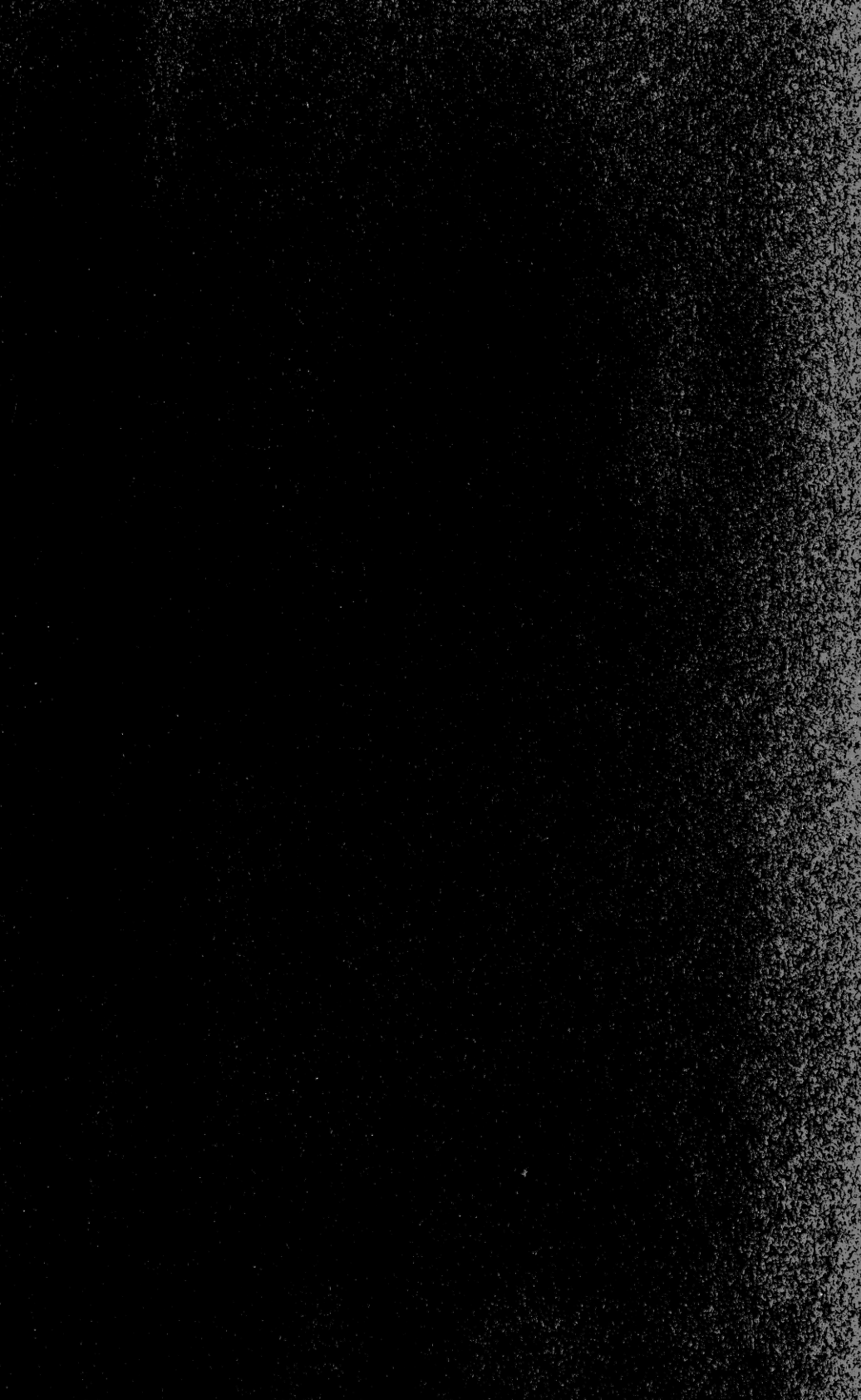



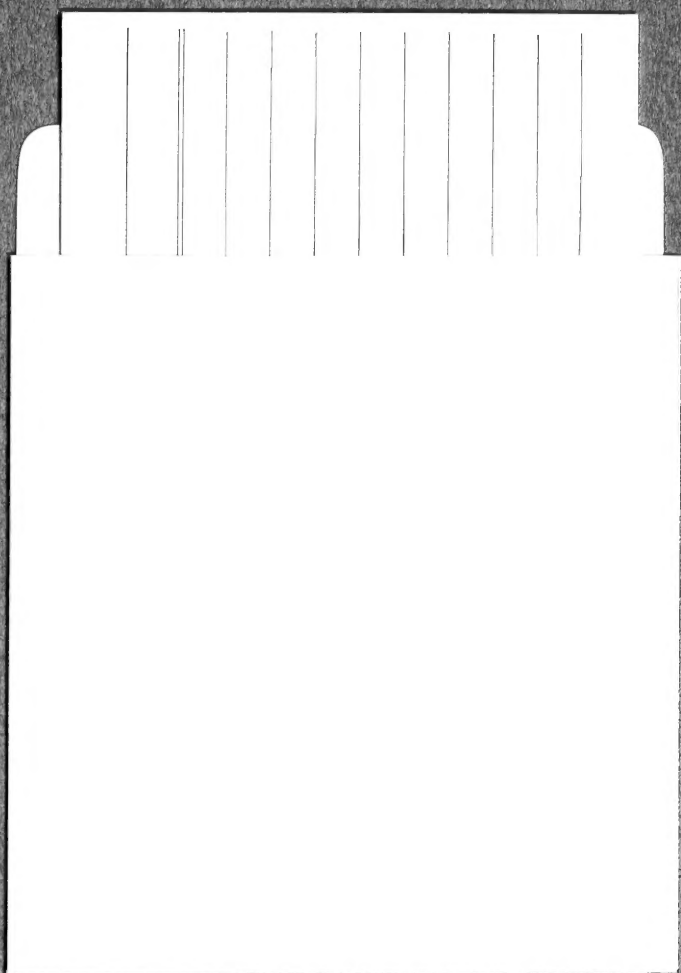

SMITHSONIAN INSTITUTION LIBRARIES



3 9088 00844 6056